

Installation Instructions

BMW X3

Part Numbers:

75371

44531

87403

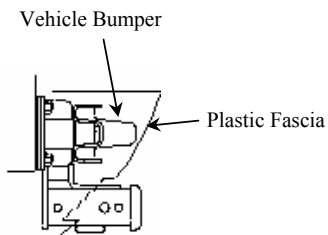

**Do Not Exceed Lower of Towing Vehicle
Manufacturer's Rating or**

Hitch type	Max Gross Trailer WT (LB)	Max Tongue WT (LB)
Weight Distributing	4,000 (1816 Kg)	400 (182 Kg)
Weight Carrying Ball Mount	3,500 (1589 Kg)	350 (159 Kg)

Hitch Shown In Proper Position

Equipment Required: Utility Knife

Fastener Kit: 75371F or 87403F

Wrenches: 8mm, 10mm, 18mm, 11/16", T-20

Drill Bits: 1/2"

C-Clamps

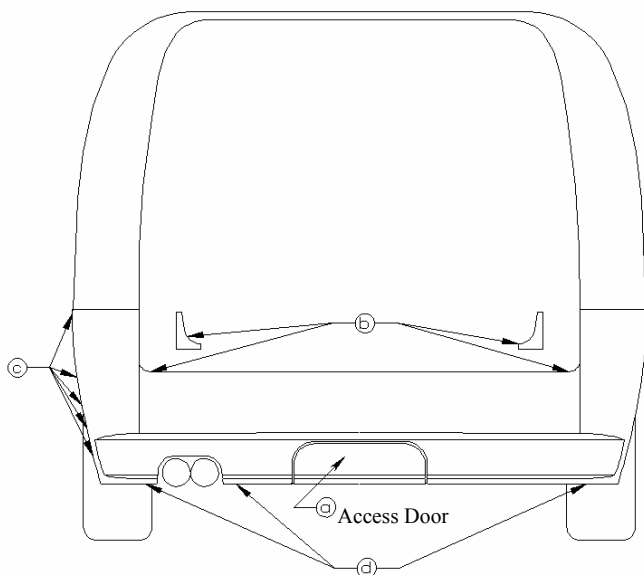

FIGURE 1

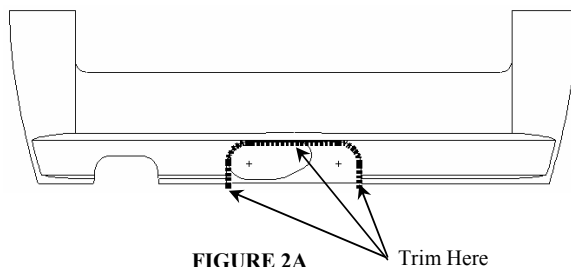

FIGURE 2A
2004 and 2005 Models

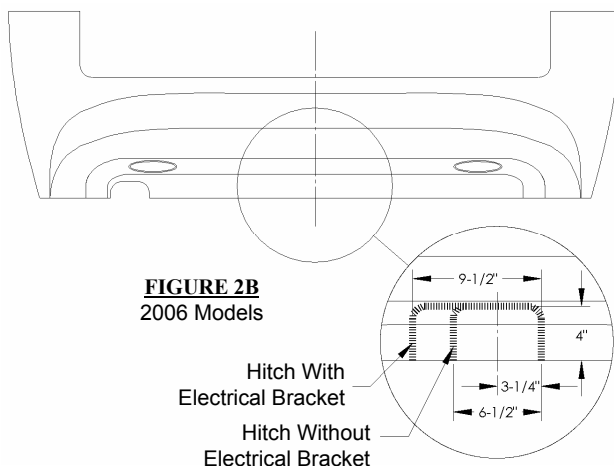

FIGURE 2B
2006 Models

NOTE: Consult with owner before trimming fascia.

1. Remove rear fascia as shown in **Figure 1**:
 - a. On 2004 and 2005 models, remove access door from bottom of fascia and return to vehicle owner.
 - b. Open tail gate, remove corner trim pieces, and remove 2 screws, 1 on each side.
 - c. Remove 2 screws inside each wheel well. Pull wheel well plastic away from fascia and remove 3 more screws, each side.
 - d. Remove 1 screw and 2 plastic nuts from bottom of fascia.
 - e. Carefully pull fascia straight back to remove.
2. Trim the fascia.
 - a. 2004 and 2005 Models: trim inner fascia as shown in **Figure 2A**. Trim the inner fascia to same profile as the access door. Trimming of the outer fascia is not required.
 - b. 2006 Models: trim the outer and inner fascia as shown in **Figure 2B**. When installing a hitch that has an electrical bracket, use the 9-1/2" wide profile. When installing a hitch without an electrical bracket, use the 6-1/2" wide profile. In both cases, measure about the fascia centerline as shown.
 - c. On newer models more extensive inner fascia trimming required for proper fit. As shown in **Figure 5**.

Note: check hitch frequently, making sure all fasteners and ball are properly tightened. If hitch is removed, plug all holes in trunk pan or other body panels to prevent entry of water and exhaust fumes. A hitch or ball which has been damaged should be removed and replaced. Observe safety precautions when working beneath a vehicle and wear eye protection. Do not cut access or attachment holes with a torch.

Installation Instructions

BMW X3

Part Numbers:

75371

44531

87403

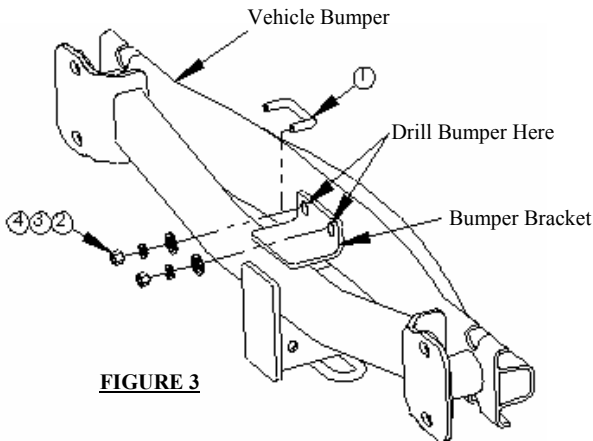

FIGURE 3

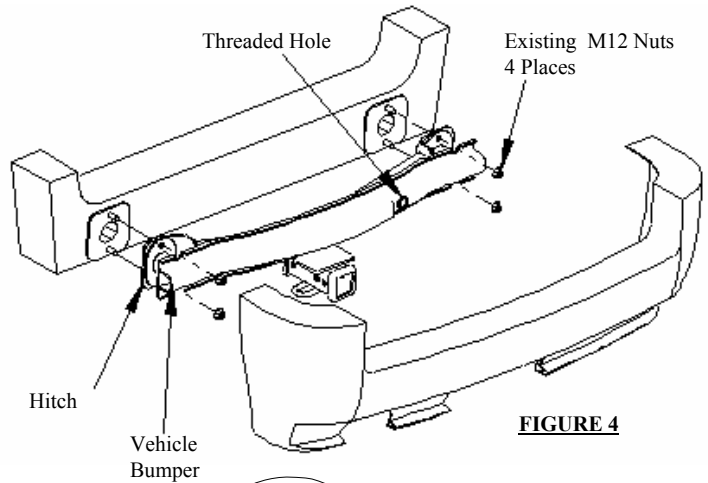
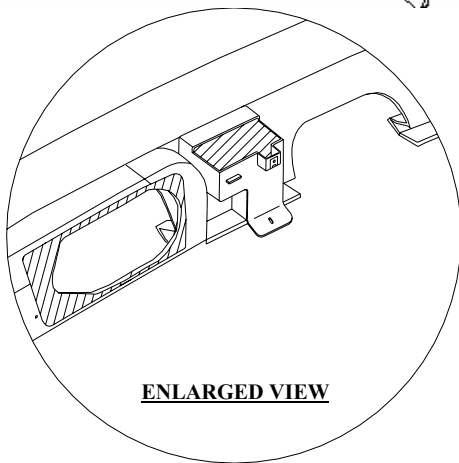

FIGURE 4



ENLARGED VIEW

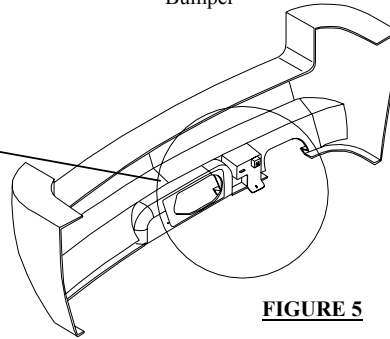

FIGURE 5

On newer models more extensive inner fascia trimming required for proper fit. See Enlarged View.

①	Qty. (1)	U-bolt, 3/8"	③	Qty. (2)	Lockwasher, 3/8"
②	Qty. (2)	Conical Washer, 3/8"	④	Qty. (2)	Hex nut 3/8"

- Remove bumper by removing 2 nuts each side, which secure bumper to rear vehicle panel. Retain nuts for hitch/bumper installation.
- Clamp the hitch and the bumper to each other off of the vehicle. Align the mounting holes on the hitch and the bumper, as shown in **Figure 3**. Make sure that the threaded hole in the bumper is on the passenger side. Drill two holes in the bumper, using the holes in the bumper bracket as a template.
- Feed the u-bolt through the bumper bracket and the bumper. Fasten in place as shown in **Figure 3**, finger tight.
- Raise hitch and bumper into position as shown in Figure 4, sandwiching hitch between vehicle end panel and bumper. Attach using 4 nuts removed in Step 3.
- Reinstall fascia.

Tighten all 3/8-16 GR5 fasteners with torque wrench to 30 Lb.-Ft (41 N-m).

Tighten all M12 CL8.8 fasteners with torque wrench to 68 Lb.-Ft (92 N-m).

Note: check hitch frequently, making sure all fasteners and ball are properly tightened. If hitch is removed, plug all holes in trunk pan or other body panels to prevent entry of water and exhaust fumes. A hitch or ball which has been damaged should be removed and replaced. Observe safety precautions when working beneath a vehicle and wear eye protection. Do not cut access or attachment holes with a torch.