

# Installation Instructions

## Volkswagen Touareg

Part Numbers:

**75363**

**44530**

**82301**

**Do Not Exceed Lower of Towing Vehicle  
Manufacturer's Rating or**

Hitch type	Max Gross Trailer WT (LB)	Max Tongue WT (LB)
Weight Distributing	<b>6000 (2 724 kg)</b>	<b>600 (272 kg)</b>
Weight Carrying Ball Mount	<b>6000 (2 724 kg)</b>	<b>600 (272 kg)</b>

**Wiring Access Location:** SUV3, SUV4

### Hitch Shown In Proper Position

#### Equipment Required:

**Fastener Kit:** 75363F

**Wrenches:** 18mm, 7/8", T-25, T-27

**Drill Bits:** 1/2"

**Note:** Hitch installation can be made easier with a "cutter" type drill bit.

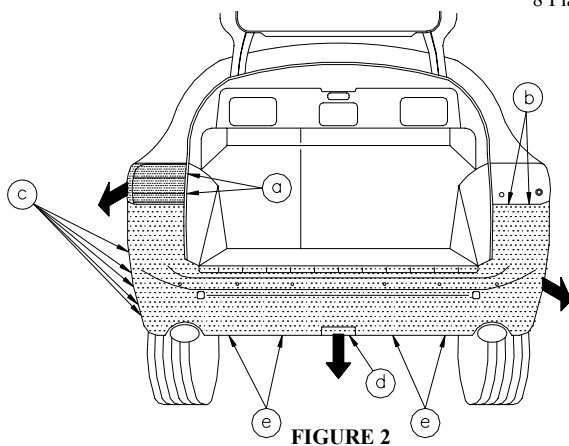

**FIGURE 2**

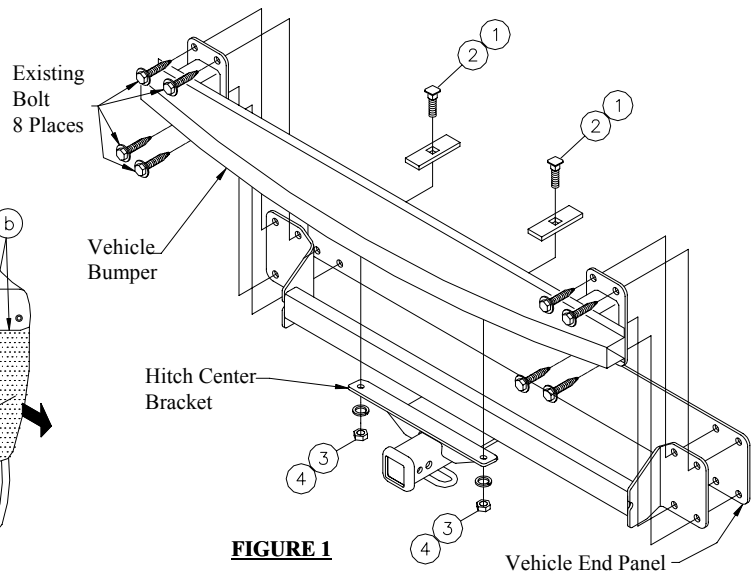

**FIGURE 1**

①	Qty. (2)	Carriage bolt 1/2" x 1 3/4"	③	Qty. (2)	Lock washer 1/2"
②	Qty. (2)	Block 1/4" x 1" x 3"	④	Qty. (2)	Hex nut 1/2"

1. Remove rear fascia as shown in figure 2:

- Remove tail lights by removing 2 screws, each side, inside lift gate opening and carefully pulling tail light straight back.
- Remove 2 screws, each side, which fasten fascia under tail light.
- Remove 5 screws inside each wheel well.
- Remove access panel from bottom of fascia and return to vehicle owner.
- Remove 4 screws from bottom of fascia.
- Carefully pull fascia straight back to remove.

2. Remove bumper by removing 4 bolts each side, which secure bumper to rear vehicle panel. Retain bolts for hitch/bumper installation.

3. Raise hitch and bumper into position as shown, sandwiching hitch between vehicle end panel and bumper. Before tightening, position hitch so that center bracket contacts bottom surface of steel bumper as shown in figure 1.

4. Using hitch as a template, drill 2 holes into bumper thru holes in hitch center bracket.

**Note:** Hitch installation can be made easier with a "cutter" type drill bit.

5. Install carriage bolts and block thru holes in bumper (drilled in step 4) and down thru holes in hitch center bracket. Install lock washers and nuts.

**Tighten all 1/2-13 GR5 fasteners with torque wrench to 75 Lb.-Ft.**

**Tighten all M12 CL8.8 fasteners with torque wrench to 68 Lb.-Ft.**

6. Reinstall fascia.

Note: check hitch frequently, making sure all fasteners and ball are properly tightened. If hitch is removed, plug all holes in trunk pan or other body panels to prevent entry of water and exhaust fumes. A hitch or ball which has been damaged should be removed and replaced. Observe safety precautions when working beneath a vehicle and wear eye protection. Do not cut access or attachment holes with a torch.