

Installation Instructions

Part Numbers:

75280

44528

70754

Honda Ridgeline

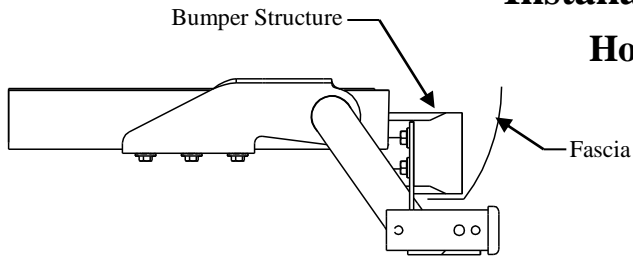

**Do Not Exceed Lower of Towing Vehicle
Manufacturer's Rating or**

Hitch type	Max Gross Trailer WT (LB)	Max Tongue WT (LB)
Weight Distributing	7500 (3405 Kg.)	750 (341 Kg.)
Weight Carrying Ball Mount	5000 (2270 Kg.)	750 (341 Kg.)

Wiring Access Location: PU1, PU2

Hitch Shown In Proper Position

Equipment Required:

Fastener Kit: 75280F

Wrenches: 10mm, 17mm, 19mm

Drill Bits: None

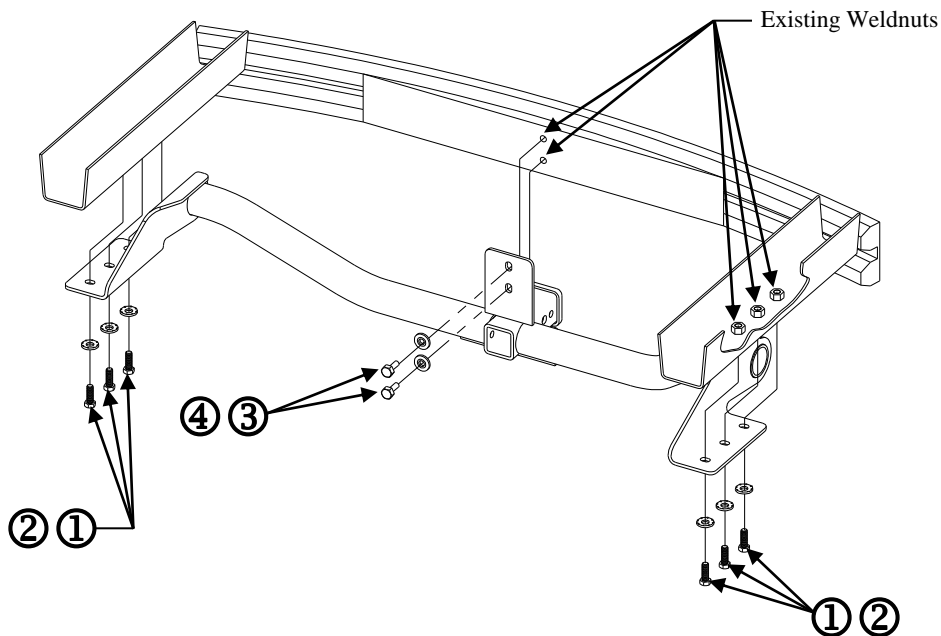

①	Qty. (6)	Hex Bolt M12 x 1.25 x 35mm CL8.8	③	Qty. (2)	Hex Bolt M10 x 1.25 x 30mm CL8.8
②	Qty. (6)	Conical Toothed Washer 1/2"	④	Qty. (2)	Conical Toothed Washer 7/16"

1. Lower the exhaust and remove the muffler heat shield.
2. Raise the hitch into position as shown.
3. Install the six (6) M12 fasteners into the frame rails and the two (2) M10 fasteners into the bumper structure as shown.
4. Re-install the heat shield and the exhaust.

Tighten all M10 CL8.8 fasteners with torque wrench to 42 Lb.-Ft. (57 N*M)

Tighten all M12 CL8.8 fasteners with torque wrench to 76 Lb.-Ft. (103 N.*M)

Note: check hitch frequently, making sure all fasteners and ball are properly tightened. If hitch is removed, plug all holes in trunk pan or other body panels to prevent entry of water and exhaust fumes. A hitch or ball which has been damaged should be removed and replaced. Observe safety precautions when working beneath a vehicle and wear eye protection. Do not cut access or attachment holes with a torch.