

INSTALLATION INSTRUCTIONS

VEHICLE

CADILLAC SRX

EQUIPMENT REQUIRED: CUT-OFF WHEEL OR HACKSAW, TIN SNIPS
 WIRING ACCESS LOCATION: SUV1, SUV2
 DRILL BITS: NONE
 HITCH REQUIRES 5/8" PIN AND CLIP IF STABILIZING PIN IS NOT INSTALLED.
 WRENCHES: (TIGHTEN ALL FASTENERS WITH TORQUE WRENCH) 13mm, 19mm

DO NOT EXCEED LOWER OF
 TOWING VEHICLE MFR'S RATINGS OR

HITCH TYPE ▼	MAX GROSS TRLR WT(LB)	MAX TONGUE WT(LB)
WEIGHT DISTRIBUTING	5000	500
WEIGHT CARRYING BALL MOUNT	3500	350

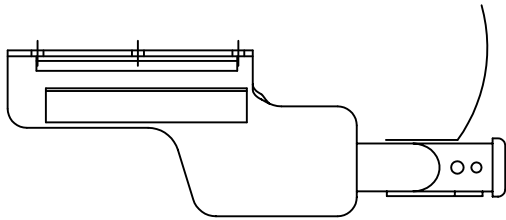

HITCH SHOWN IN PROPER POSITION

FASTENERS TYPICAL BOTH SIDES OF VEHICLE

EXISTING WELDNUTS (6) PLACES

OPTIONAL LOCKING STABILIZING PIN

J-PIN

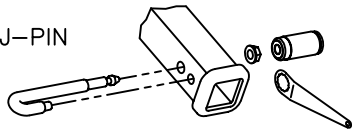

(Order Separately)

FIGURE 1

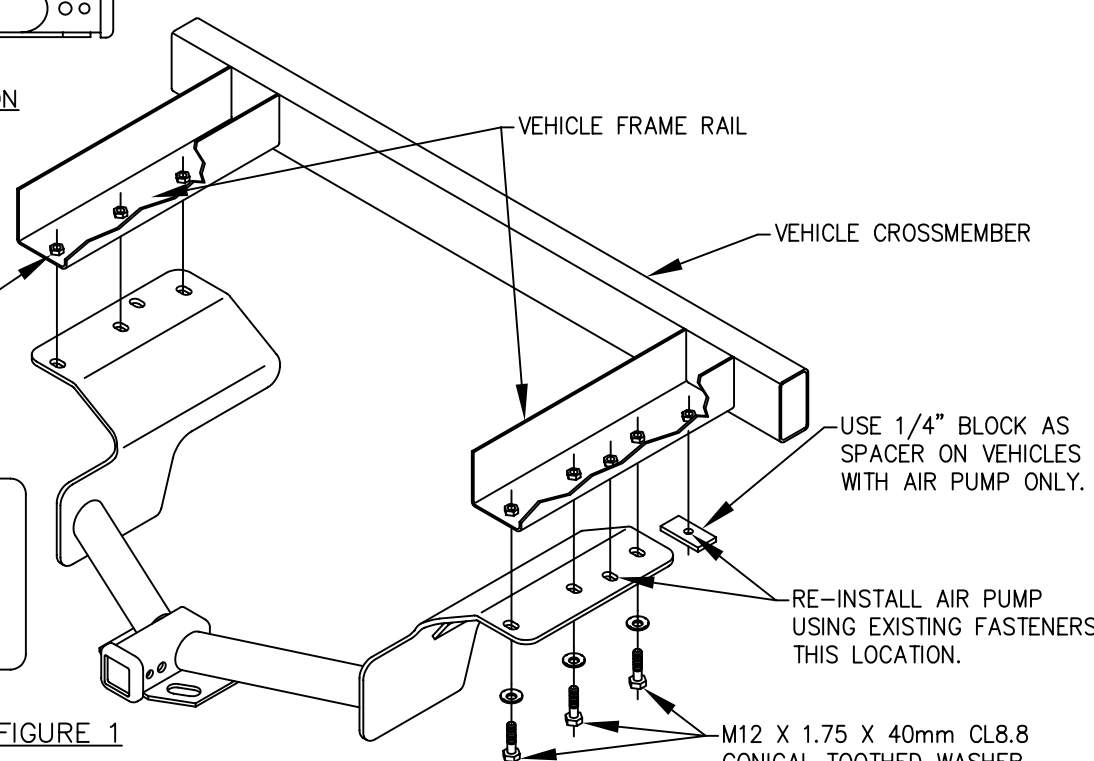

M12 X 1.75 X 40mm CL8.8 CONICAL TOOTHED WASHER

1. LOWER SPARE TIRE.
2. DISCONNECT RUBBER EXHAUST HANGERS FROM EXHAUST HANGER BRACKETS, THREE EACH SIDE (ONE FORWARD AND TWO REARWARD OF MUFFLER).
3. REMOVE REARMOST EXHAUST HANGER BRACKETS, ONE EACH SIDE, BY REMOVING (3) NUTS, WHICH SECURE HANGER BRACKETS TO STUDS IN VEHICLE BULKHEAD, AND UNFASTENING RETAINING CLIPS, ONE EACH SIDE.
 NOTE: EXHAUST HANGER BRACKETS WILL BE REINSTALLED IN STEP 6.
4. CAREFULLY CUT OFF LOWER STUD, EACH SIDE, AS CLOSE TO BULKHEAD AS POSSIBLE (SEE FIGURE 2). DO NOT CUT OFF TWO (2) UPPER STUDS.
5. MODIFY HEAT SHIELDS AS SHOWN IN FIGURE 3.
 NOTE: DO NOT REMOVE PUSH-IN FASTENERS WHICH ATTACH HEAT SHIELDS TO VEHICLE. ONCE PUSH-IN FASTENERS ARE REMOVED, THEY CANNOT BE RE-USED.
6. RE-INSTALL EXHAUST HANGER BRACKETS, USING (2) OF THE (3) NUTS REMOVED IN STEP 3, ON (2) UPPER STUDS (SEE FIG. 2). HANGER BRACKET MUST BE ORIENTED SO THAT SQUARE HOLE IN BRACKET ALIGNS WITH RETAINING CLIP IN VEHICLE BULKHEAD.
7. RAISE HITCH INTO POSITION AS SHOWN IN FIGURE 1.
 NOTE: ON VEHICLES EQUIPPED WITH AIR PUMP MOUNTED ON PASSENGER'S SIDE FRAME RAIL, TEMPORARILY REMOVE PUMP BY REMOVING TWO (2) BOLTS WHICH SECURE PUMP TO FRAME. RETAIN FASTENERS FOR REINSTALLATION OF PUMP AFTER HITCH IS INSTALLED.
8. INSTALL M12 BOLTS AND 1/2" CONICAL TOOTHED WASHERS AS SHOWN IN FIGURE 1.
9. REINSTALL AIR PUMP USING EXISTING BOLTS AS SHOWN IN FIG. 1. BE SURE TO PLACE 1/4" BLOCK BETWEEN PUMP AND FRAME RAIL AT FORWARD ATTACHMENT AS SHOWN.
10. RE-CONNECT RUBBER EXHAUST HANGERS (THREE EACH SIDE).
11. RAISE SPARE TIRE.

TIGHTEN M12 CL8.8 FASTENERS TO 68 LB. FT.

APPROX WEIGHT (LB.)	FASTENER KIT
56	F75174

NOTE: Check hitch frequently, making sure all fasteners and ball are properly tightened. If hitch is removed, plug all holes in trunk pan or other body panels to prevent entry of water and exhaust fumes. A hitch or ball which has been damaged should be removed and replaced. Observe safety precautions when working beneath a vehicle and wear eye protection. Follow car maker's specs for maximum trailer weight and tongue weight. Do not cut access or attachment holes with a torch.

INSTALLATION INSTRUCTIONS

CADILLAC SRX

VEHICLE

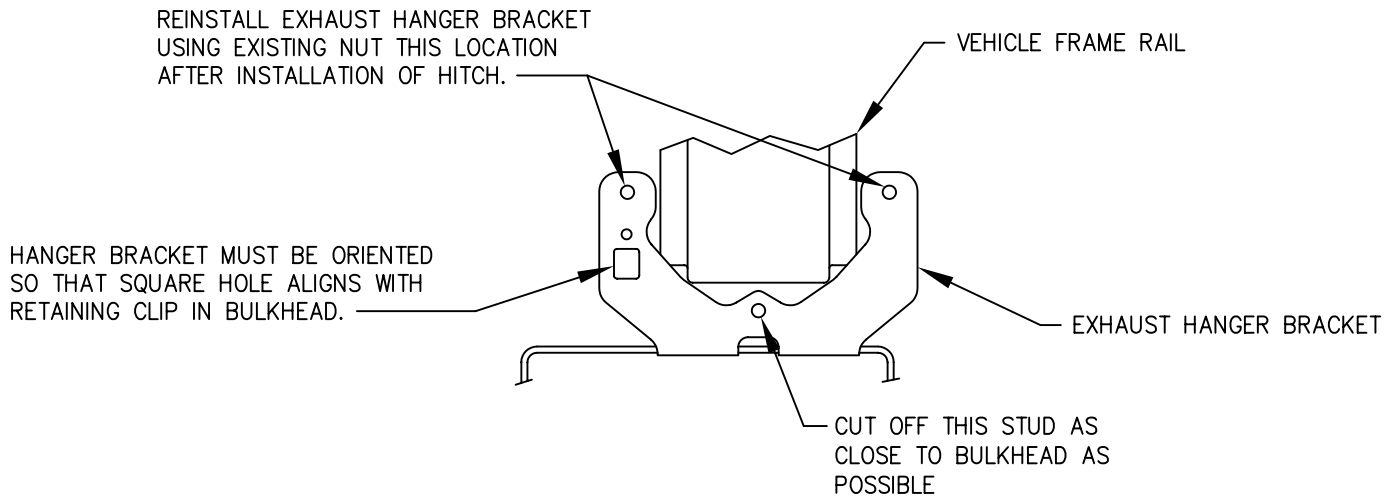

FIGURE 2
EXHAUST HANGER BRACKET

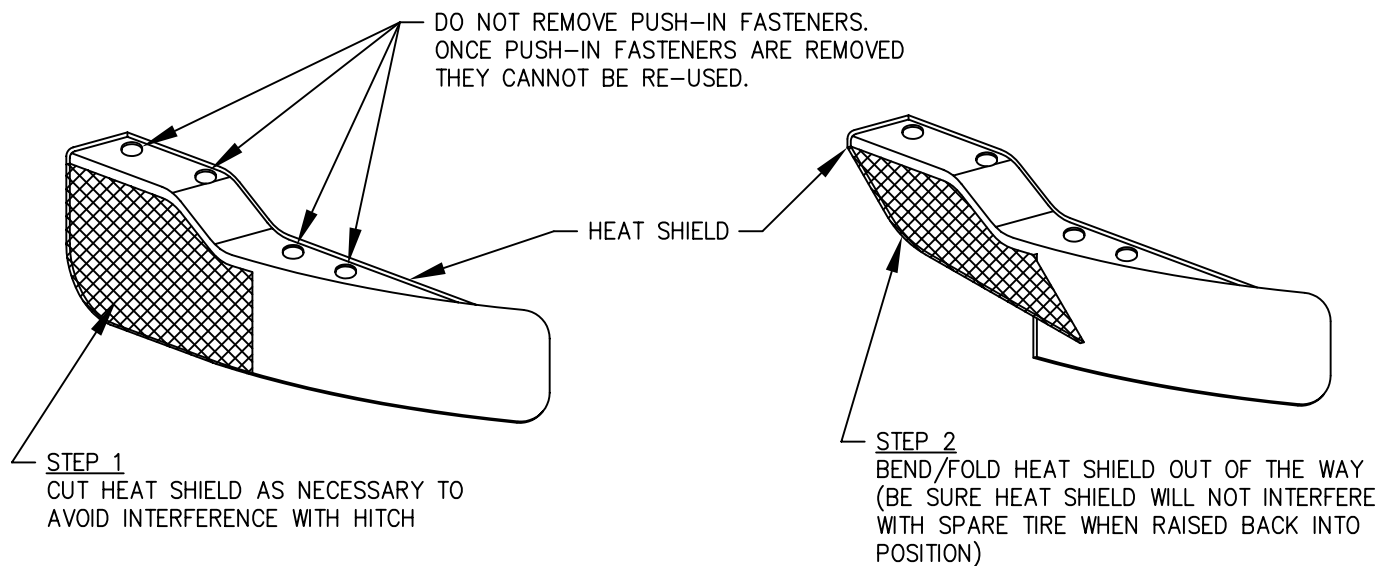

FIGURE 3
MODIFICATION OF HEAT SHIELDS
DRIVER'S SIDE HEAT SHIELD SHOWN.
MODIFICATION TYPICAL BOTH SIDES
NOTE: DO NOT REMOVE HEAT SHIELDS FROM VEHICLE TO MODIFY.

APPROX WEIGHT (LB.)	FASTENER KIT
56	F75174

NOTE: Check hitch frequently, making sure all fasteners and ball are properly tightened. If hitch is removed, plug all holes in trunk pan or other body panels to prevent entry of water and exhaust fumes. A hitch or ball which has been damaged should be removed and replaced. Observe safety precautions when working beneath a vehicle and wear eye protection. Follow car maker's specs for maximum trailer weight and tongue weight. Do not cut access or attachment holes with a torch.