

# Installation Instructions

## Dodge Durango

## Chrysler Aspen

Part Numbers:  
**75162**  
**33082**  
**87562**

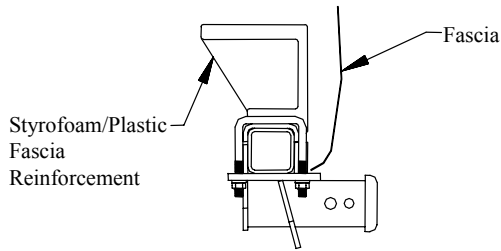

**Do Not Exceed Lower of Towing Vehicle  
 Manufacturer's Rating or**

Hitch type	Max Gross Trailer WT (LB)	Max Tongue WT (LB)
Weight Distributing	<b>9000 (4082 kg)</b>	<b>900 (408 kg)</b>
Weight Carrying Ball Mount	<b>6000 (2722 kg)</b>	<b>600 (272 kg)</b>

### Hitch Shown In Proper Position

Wiring Access Location: SUV1, SUV2

**Equipment Required:** Knife or small hand saw

**Fastener Kit:** F75162

**Wrenches:** 11/16, 3/4

**Drill Bits:** 1/2

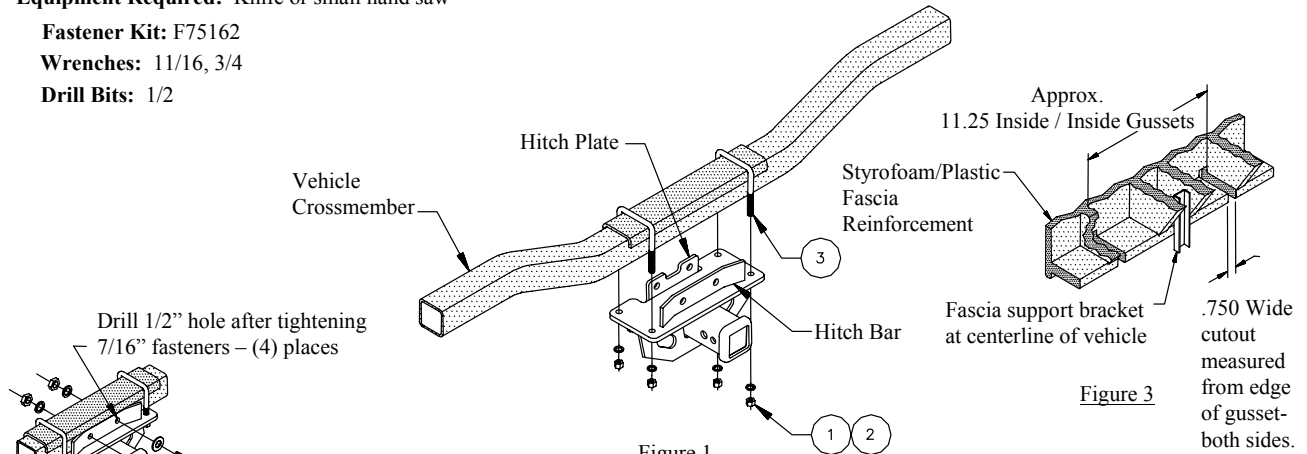

Figure 1

Figure 3

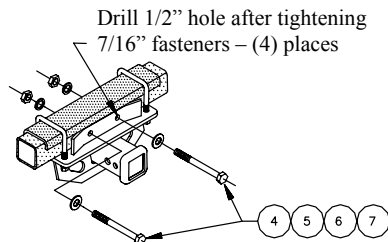

Figure 2

①	Qty. (4)	7/16-20 Hex Nut	④	Qty. (2)	1/2-13 X 4.00 GR5 Hex Bolt
②	Qty. (4)	7/16 Lockwasher	⑤	Qty. (2)	1/2 Hardened Flat Washer
③	Qty. (2)	7/16-20 U-Bolt	⑥	Qty. (2)	1/2 Lockwasher
			⑦	Qty. (2)	1/2-13 Hex Nut

- Lower spare tire.
- Trim styrofoam/plastic fascia support as shown in figure 3 for installation of u-bolts.  
**Note:** Trimming of styrofoam/plastic necessary to insure proper seating of receiver on vehicle crossmember.
- Install u-bolts over vehicle crossmember at cutouts in styrofoam/plastic.
- Raise hitch into position, attaching loosely to u-bolts with lockwashers and nuts.
- Center hitch on vehicle.  
**Tighten 7/16-20 nuts to 55 lb.-ft. (75 N\*M), hitch should fit flat against bottom of vehicle crossmember.**
- Remove (4) fasteners which secure fascia to fascia mounting brackets. Push fascia up to allow access to drill thru (2) holes in hitch bar into rear face of vehicle crossmember. Drill (2) holes thru hitch plate and into front face of vehicle crossmember.
- Install 1/2-13 X 4.00 GR5 hex bolts and hardened flat washers as shown. Install lockwashers and nuts.  
**Tighten all 1/2-13 GR5 fasteners with torque wrench to 75 Lb.-Ft. (102 N\*M)**
- Re-install fascia mounting fasteners.
- Raise spare tire back into position.

Note: check hitch frequently, making sure all fasteners and ball are properly tightened. If hitch is removed, plug all holes in trunk pan or other body panels to prevent entry of water and exhaust fumes. A hitch or ball which has been damaged should be removed and replaced. Observe safety precautions when working beneath a vehicle and wear eye protection. Do not cut access or attachment holes with a torch.