

# INSTALLATION INSTRUCTIONS

VEHICLE	HITCH NO.
DODGE RAM 1500 PICKUP	75135 37084 87532

EQUIPMENT REQUIRED: UTILITY KNIFE  
 WIRING ACCESS LOCATION: PU3  
 DRILL BITS: NONE  
 HITCH REQUIRES 5/8" PIN AND CLIP IF STABILIZING PIN IS NOT INSTALLED.  
 WRENCHES: (TIGHTEN ALL FASTENERS WITH TORQUE WRENCH) 7/8, 15/16 (WRENCH & SOCKET)

DO NOT EXCEED LOWER OF TOWING VEHICLE MFR'S RATINGS OR

HITCH TYPE	MAX GROSS TRLR WT(LB)	MAX TONGUE WT(LB)
WEIGHT DISTRIBUTING	10,000	1000
WEIGHT CARRYING BALL MOUNT	5000	500

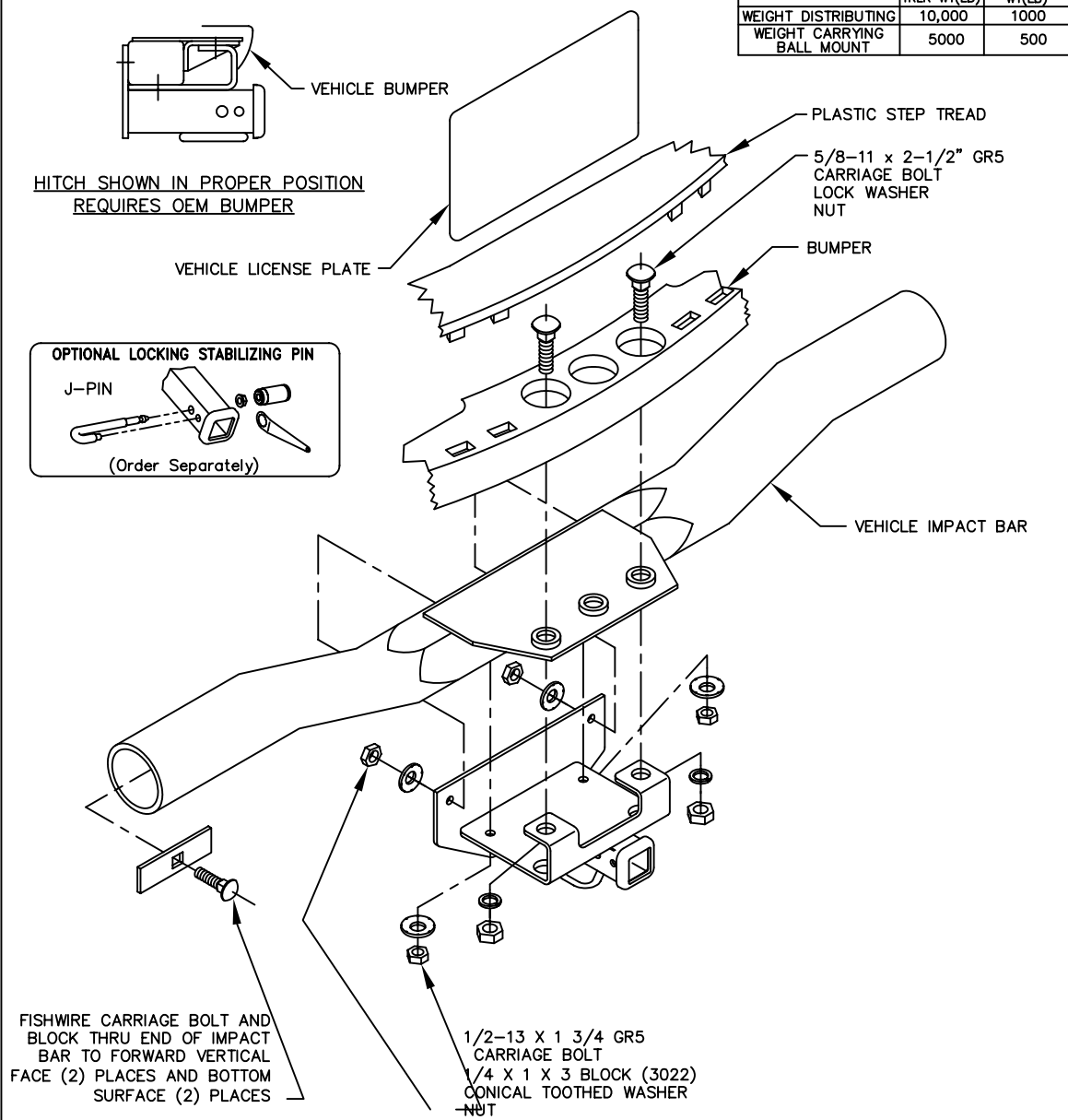

FIGURE 1

1. LOWER VEHICLE SPARE TIRE.
  2. SQUEEZE TABS THAT HOLD CENTER PORTION OF PLASTIC STEP TREAD TO IMPACT BAR WITH PLIERS (4 PLACES - 2 ON EACH END).
  3. RAISE HITCH INTO POSITION AND LIFT STEP TREAD.
  4. INSTALL 5/8 CARRIAGE BOLTS DOWN THRU HOLES BETWEEN BUMPER AND IMPACT BAR. INSTALL LOCK WASHERS AND NUTS (HAND TIGHTEN ONLY UNTIL ALL FASTENERS ARE INSTALLED).
  5. FISHWIRE (2) CARRIAGE BOLTS AND 1/4 X 1 X 3 BLOCKS (3022) THRU END OF IMPACT BAR AND INTO HOLES IN BOTTOM SURFACE OF IMPACT BAR. INSTALL CONICAL TOOTHED WASHERS AND NUTS.
  6. FISHWIRE CARRIAGE BOLTS AND 1/4 X 1 X 3 BLOCKS (3022) THRU END OF IMPACT BAR AND INTO SLOTS IN FORWARD FACE OF IMPACT BAR AND HOLES IN VERTICAL PLATE ON HITCH. INSTALL CONICAL TOOTHED WASHERS AND NUTS.  
 TIGHTEN 1/2-13 GR5 FASTENERS TO 75 LB.-FT.  
 TIGHTEN 5/8-11 GR5 FASTENERS TO 150 LB.-FT.
- NOTE: TIGHTENING WILL CAUSE 5/8 CARRIAGE BOLT TO DRAW DOWN INTO IMPACT BAR HOLES. CARRIAGE BOLT MUST BE COMPLETELY SEATED TO IMPACT BAR.
7. RAISE SPARE TIRE.
  8. TAP LIGHTLY ON PLASTIC STEP TREAD TO SECURE TO BUMPER.

APPROX WEIGHT (LB.)	FASTENER KIT
26	F75135

NOTE: Check hitch frequently, making sure all fasteners and ball are properly tightened. If hitch is removed, plug all holes in trunk pan or other body panels to prevent entry of water and exhaust fumes. A hitch or ball which has been damaged should be removed and replaced. Observe safety precautions when working beneath a vehicle and wear eye protection. Follow car maker's specs for maximum trailer weight and tongue weight. Do not cut access or attachment holes with a torch.