

INSTALLATION INSTRUCTIONS

EQUIPMENT REQUIRED: NONE

WIRING ACCESS LOCATION:

DRILL BITS: NONE

HITCH REQUIRES 5/8" PIN AND CLIP IF STABILIZING PIN (7651) IS NOT INSTALLED.

WRENCHES: (TIGHTEN ALL FASTENERS WITH TORQUE WRENCH) 18mm, 19mm

VEHICLE

JEEP LIBERTY

HITCH NO.

75128
87006

DO NOT EXCEED LOWER OF
TOWING VEHICLE MFR'S RATINGS OR

HITCH TYPE	MAX GROSS TRLR WT(LB)	MAX TONGUE WT(LB)
WEIGHT DISTRIBUTING	7500	750
WEIGHT CARRYING BALL MOUNT	5000	750

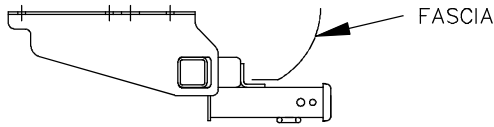

HITCH SHOWN IN PROPER POSITION

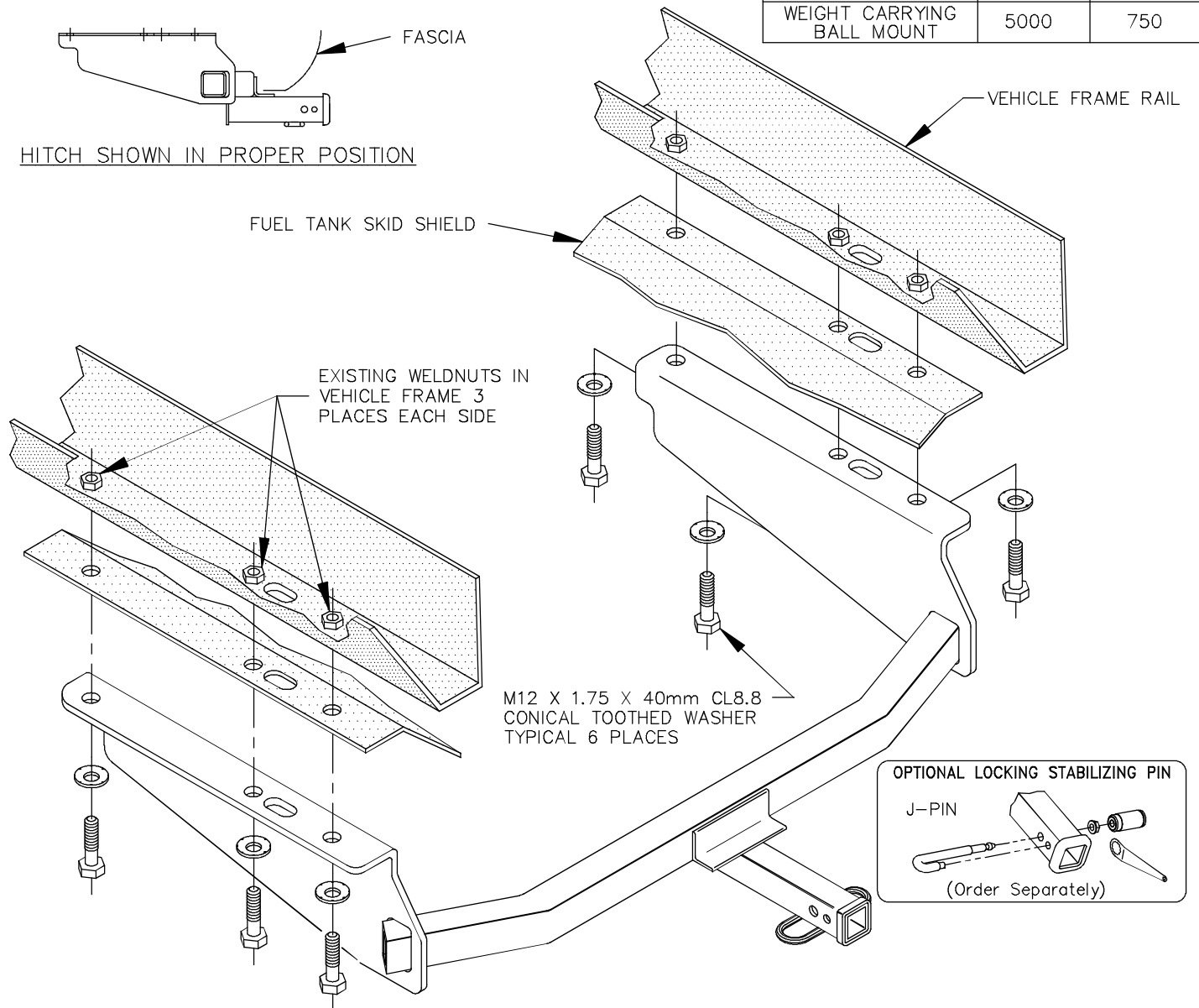

1. IF VEHICLE IS EQUIPPED WITH A FUEL TANK SKID SHIELD, REMOVE SIX (6) M12 FASTENERS HOLDING SKID SHIELD TO VEHICLE FRAME RAILS AND DISCARD BOLTS.
2. RAISE HITCH INTO POSITION AND INSTALL FASTENERS AS SHOWN ABOVE. FUEL TANK SKID SHIELD WILL BE SANDWICHED BETWEEN HITCH AND VEHICLE FRAME RAILS.

TIGHTEN ALL M12 CL8.8 FASTENERS TO 68 LB-FT.

APPROX WEIGHT (LB.)	44	FASTENER KIT NO.	F75128
---------------------	----	------------------	--------

NOTE: Check hitch frequently, making sure all fasteners and ball are properly tightened. If hitch is removed, plug all holes in trunk pan or other body panels to prevent entry of water and exhaust fumes. A hitch or ball which has been damaged should be removed and replaced. Observe safety precautions when working beneath a vehicle and wear eye protection. Follow car maker's specs for maximum trailer weight and tongue weight. Do not cut access or attachment holes with a torch.