

Front Mounted Receiver Installation Instructions Ford Econoline

Part Numbers:
65053

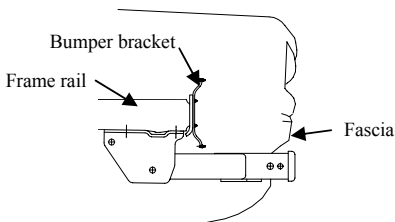

**Note: Fascia trim required.
Obtain vehicle owners approval
before cutting**

**CARGO CAPACITY – Do not exceed
500 LB. (227 Kg) or Truck Front
Gross Axle Weight Rating, (GAWR).**

9,000 lb.	MAXIMUM WINCH LINE PULL
(4086 Kg)	MAXIMUM WINCH LINE PULL

Receiver Shown In Proper Position

Equipment Required: Utility Knife

Fastener Kit: 65053F

**Wrenches: 8mm, 21mm deep
well socket, & 7/8"**

Drill Bits: 3/8" & 1/2"

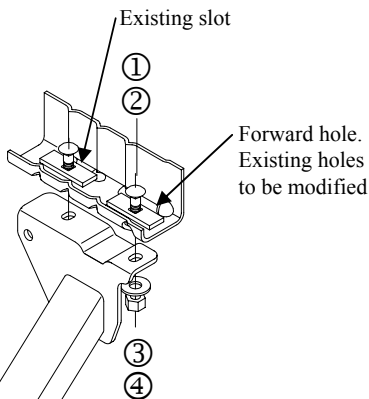

Figure 1.

**Note: Fasteners typical
both sides**

**Fascia trim required. Obtain vehicle
owners approval before cutting**

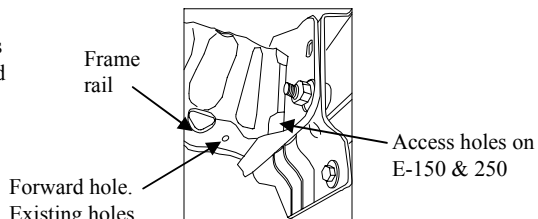

Figure 2.
E-150 & E-250

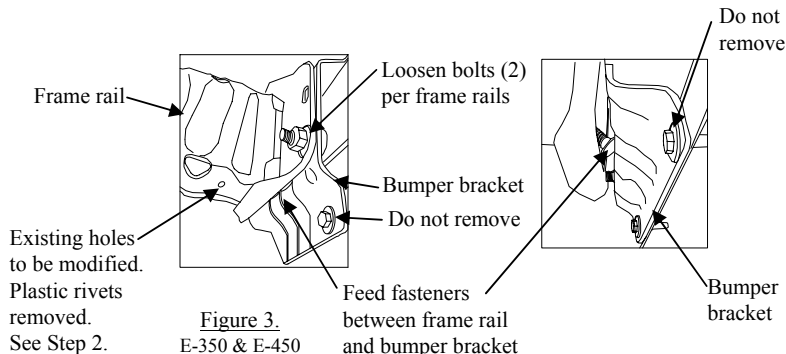

Figure 3.
E-350 & E-450

NOTE: If front mounted license plate is present, license plate holder relocation and/or modification required to install hitch, see 49802 or 5443 sold separately.

①	Qty. (4)	Carriage Bolt, 1/2"-13 x 1-3/4"	④	Qty. (4)	Nut, 1/2"
②	Qty. (4)	Spacer, 1/4" x 1" x 3"	⑤	Qty. (4)	Pull Wire
③	Qty. (4)	Conical Toothed Washer, 1/2"			

1. Remove splash guard (4) bolts. See Figure 5. Illustration on last page.
2. If present (E-350 & E-450) remove any plastic rivets from (see Figure 3) forward attachment on vehicle. Fold plastic between plastic covering and frame rail.
3. Enlarge forward hole on vehicle with a 1/2 drill bit.
4. Trim lower fascia as shown in Figure 4. Illustration on last page.
5. Feed carriage bolts and spacers thru access point at forward end of frame rail (E-150 & E-250) using a pull wire as shown. See Figure 2. Note: On E-350 & E-450 loosen bolts at the end of the frame rail (See Figure 3) and bumper bracket enough to feed fasteners into the opening at the end of the frame rail. Do not remove bolts completely. See Figure 3. The bumper may shift downward slightly. After feeding fasteners into frame rail, raise and retighten bolts.
6. Raise hitch into position and fasten as shown above.
7. Return splash guard to owner or obtain owner permission to trim splash guard as shown in Figure 5. Illustration on last page. Trimming recommended

Tighten all 1/2 GR5 fasteners with torque wrench to 75 Lb.-Ft (102 N-m).

Note: check hitch frequently, making sure all fasteners and ball are properly tightened. If hitch is removed, plug all holes in trunk pan or other body panels to prevent entry of water and exhaust fumes. A hitch or ball which has been damaged should be removed and replaced. Observe safety precautions when working beneath a vehicle and wear eye protection. Do not cut access or attachment holes with a torch.

Front Mounted Receiver Installation Instructions Ford Econoline

Part Numbers:
65053

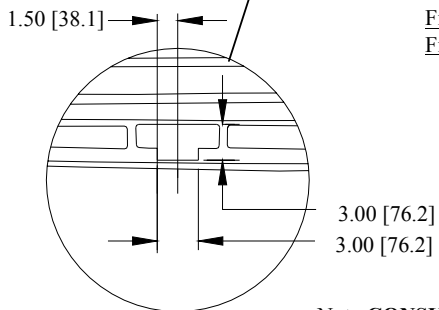
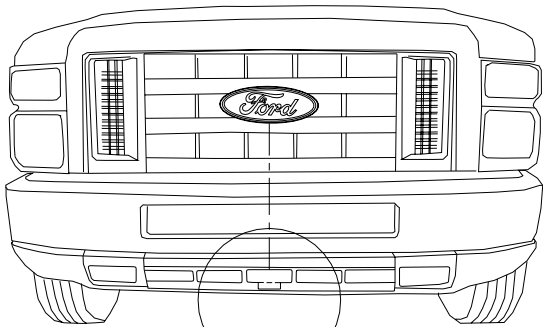

Figure 4.
Figura 4

4. Trim lower fascia as shown in Figure 4.
 - a. Locate the center of the fascia from left to right and mark 1-1/2" each side. (3" square)
 - b. Then mark 3" down from existing opening to create a square cut-out
 - c. Drill (2) 3/8" hole in corners.
 - d. Carefully cut the 3" hole from the fascia.

Note: CONSULT VEHICLE OWNER BEFORE TRIMMING.

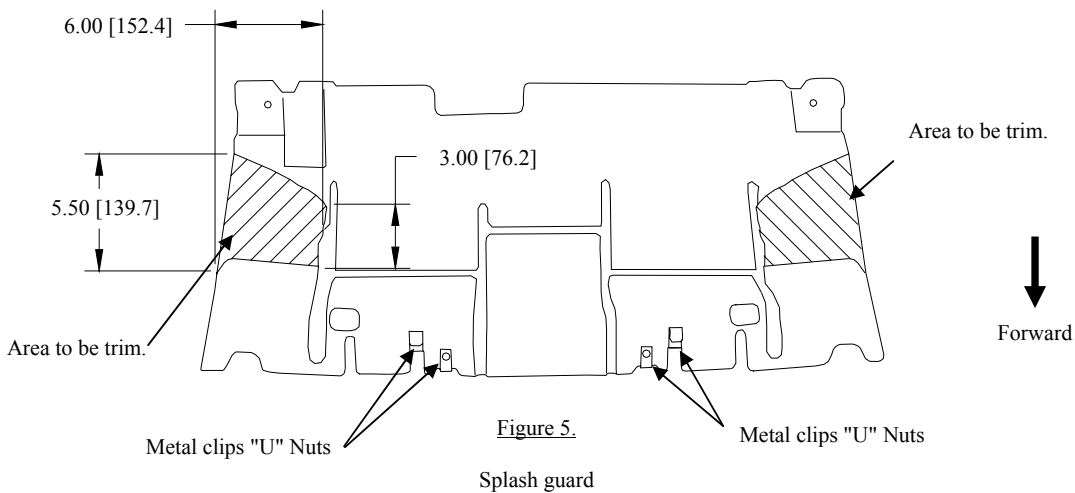

Figure 5.

Splash guard

Trimming typical both sides of splash guard.uras

Tighten all 1/2 GR5 fasteners with torque wrench to 75 Lb.-Ft (102 N-m).

Note: check hitch frequently, making sure all fasteners and ball are properly tightened. If hitch is removed, plug all holes in trunk pan or other body panels to prevent entry of water and exhaust fumes. A hitch or ball which has been damaged should be removed and replaced. Observe safety precautions when working beneath a vehicle and wear eye protection. Do not cut access or attachment holes with a torch.