

# Installation Instructions

Part Numbers:

## GMC Full Size Van

**41946**

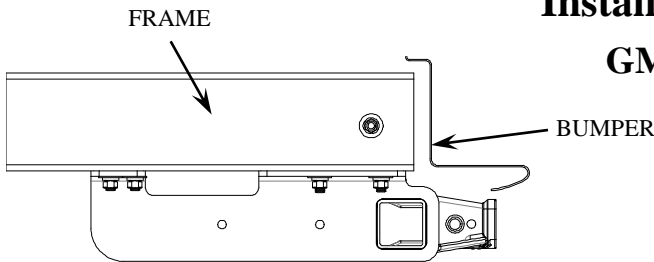

**Do Not Exceed Lower of Towing Vehicle  
Manufacturer's Rating or**

Hitch type	Max Gross Trailer WT (LB)	Max Tongue WT (LB)
Weight Distributing	<b>13,000 (5902 Kg)</b>	<b>1,300 (590 Kg)</b>
Weight Carrying Ball Mount	<b>10,000 (4540 Kg)</b>	<b>1,500 (681 Kg)</b>

### Hitch Shown In Proper Position

**Wiring Access Location: SUV3, SUV4**

#### Equipment Required:

**Fastener Kit: 41946F**

**Wrenches: 13/16", 15/16"**

**Drill Bits: 9/16"**

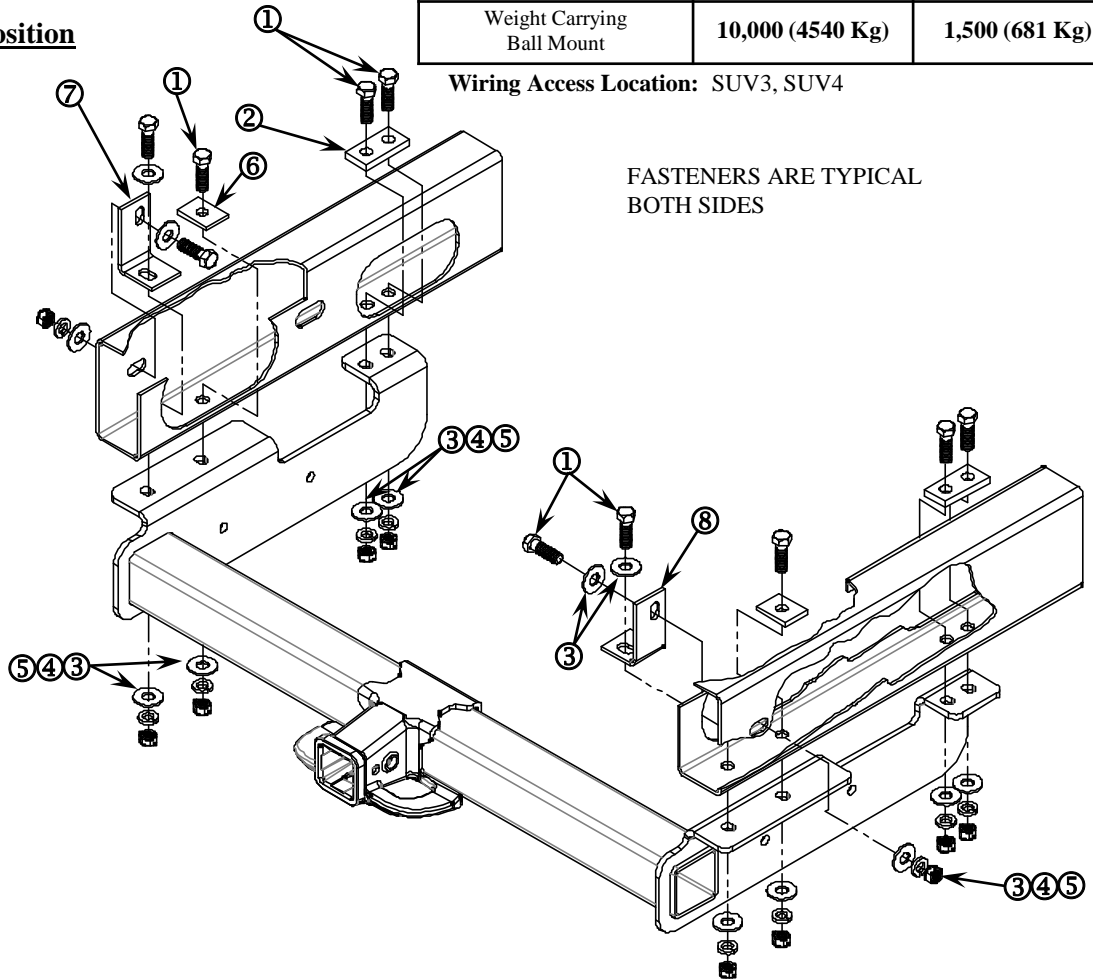

FASTENERS ARE TYPICAL  
BOTH SIDES

①	Qty. (10)	BOLT-HEX 9/16"-12 X 1.75 GR5	⑤	Qty. (10)	NUT - 9/16-12
②	Qty. (2)	BLOCK - 3/8" X 1-1/2" X 3"	⑥	Qty. (2)	BLOCK - 1/4" X 1-1/2" X 2"
③	Qty. (14)	WASHER - FLAT 9/16"	⑦	Qty. (1)	BRACKET - L.H.
④	Qty. (10)	WASHER - LOCK 9/16"	⑧	Qty. (1)	BRACKET - R.H.

1. Enlarge existing holes to 9/16" (8 places)
2. Insert bolts, brackets, and block through existing access slots and into attachment holes as shown above, each side.
3. Raise hitch into position and fasten with flat washers, lock washers, and nuts as shown
4. Tighten all fasteners.

Tighten all 9/16" fasteners with torque wrench to 110 Lb.-Ft. (149 N\*M)

Note: check hitch frequently, making sure all fasteners and ball are properly tightened. If hitch is removed, plug all holes in trunk pan or other body panels to prevent entry of water and exhaust fumes. A hitch or ball which has been damaged should be removed and replaced. Observe safety precautions when working beneath a vehicle and wear eye protection. Do not cut access or attachment holes with a torch.