

# Installation Instructions

## GMC & Chevrolet 2500HD/3500/3500HD Sierra & Silverado Trucks, Classic & New Body - All

Part Numbers:  
**41944**

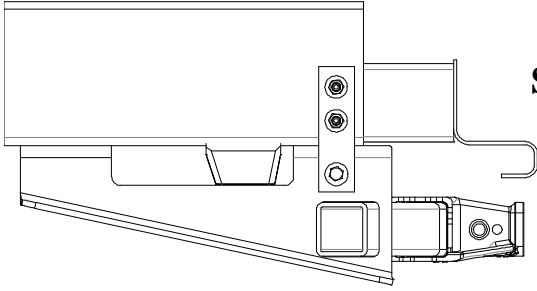

**Hitch Shown In Proper Position**

Do Not Exceed Lower of Towing Vehicle  
Manufacturer's Rating or

Hitch type	Max Gross Trailer WT (LB)	Max Tongue WT (LB)
Weight Distributing	<b>16,000 (7264 kg)</b>	<b>1,600 (726 kg)</b>
Weight Carrying Ball Mount	<b>13,000 (5902 kg)</b>	<b>1,950 (886 kg)</b>

**Equipment Required:**

- Fastener Kit: 41944F
- Wrenches: 13/16", 7/8", 18mm, 21mm, 22mm
- Drill Bits: None

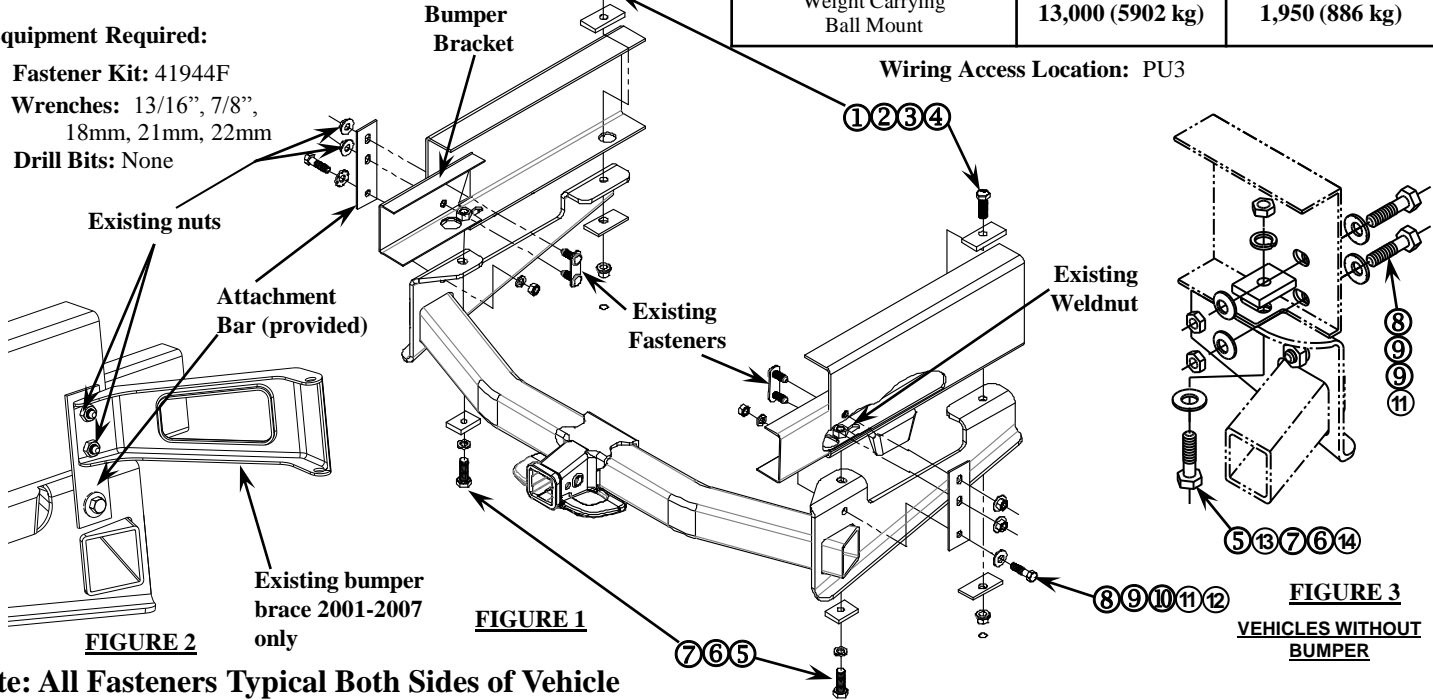

**FIGURE 2**

**FIGURE 1**

**FIGURE 3  
VEHICLES WITHOUT BUMPER**

**Note: All Fasteners Typical Both Sides of Vehicle**

①	Qty. (2)	BOLT - M14 X 1.5 X 45mm CL10.9 (FINE THREAD)	⑧	Qty. (6)	BOLT - M12 X 1.75 X 45mm CL 10.9
②	Qty. (2)	BLOCK - 3/8" X 1-1/2" X 3"	⑨	Qty. (10)	CONICAL WASHER - 1/2"
③	Qty. (2)	BLOCK - 1/4" X 1-1/2" X 3", offset hole	⑩	Qty. (4)	FLAT WASHER - 1/2"
④	Qty. (2)	NUT - M14 x 1.5 CL 10.9	⑪	Qty. (2)	LOCK WASHER - 1/2"
⑤	Qty. (2)	BOLT - M14 X 2.0 X 45mm CL10.9 (COURSE THREAD)	⑫	Qty. (6)	NUT - M12 X 1.75 CL 10
⑥	Qty. (2)	LOCK WASHER - 9/16"	⑬	Qty. (2)	FLAT WASHER - 9/16"
⑦	Qty. (2)	BLOCK - 3/8" X 1-1/2" X 2"	⑭	Qty. (2)	NUT - M14 X 2.00 CL 8

- Remove existing M14 bolts from bottom of each truck frame rail bumper bracket. Give bolts to customer.
- Lift hitch into position, locating rearmost slots in hitch under existing weldnuts in truck frame.
- Install new M14 bolts through lockwashers, blocks and hitch into weldnuts in truck frame.
- Remove M12 side nuts and bolt plates at the end of the frame. Keep these for re-installation later.
- If installing on a 2001-07 model, loosen the nuts at the bumper end of the bumper brace allowing it to swing away.
- Place attachment bars as shown and loosely bolt to hitch. On the 01-07 models, swing brace back and fasten as shown.
- Install remaining fasteners as shown through existing large holes in truck frame. Make sure to use thinner (1/4" x 3") block below hitch and orient hole in block so that block lays flat against hitch when tightened.

**NOT ALL FASTENERS ARE USED IN ALL APPLICATIONS**

Tighten all M14 X 1.5 (fine thread) fasteners with torque wrench to 160 Lb.-Ft. (217 N\*M)

Tighten all M14 X 2.0 (course thread) fasteners with torque wrench to 100 Lb.-Ft. (136 N\*M)

Tighten all M12 fasteners with torque wrench to 92 Lb.-Ft. (125 N\*M)

Note: check hitch frequently, making sure all fasteners and ball are properly tightened. If hitch is removed, plug all holes in trunk pan or other body panels to prevent entry of water and exhaust fumes. A hitch or ball which has been damaged should be removed and replaced. Observe safety precautions when working beneath a vehicle and wear eye protection. Do not cut access or attachment holes with a torch.