

# Installation Instructions

Part Numbers:

**Chevrolet Equinox  
Pontiac Torrent  
Saturn Vue  
GMC Terrain**

**36408  
06391  
90145**

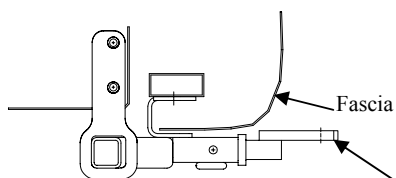

## Hitch Shown In Proper Position

### Equipment Required:

**Fastener Kit:** 36408F

**Wrenches:** 18mm, 19mm & 3/4  
Saturn Vue: Open end 3/4 wrench,  
Equinox: 6" Ratchet Extension

**Drill Bits:** None

### Drawbar Kit:

36051 Or 90001

Drawbar must be used in the  
**RISE** position only.

### Do Not Exceed Lower of Towing Vehicle Manufacturer's Rating or

**3500 LB Max Gross Trailer Weight**

**300 LB Max Tongue Weight**

**Wiring Access Location:** Chevrolet SUV3  
Pontiac SUV3  
Saturn SUV1, SUV2

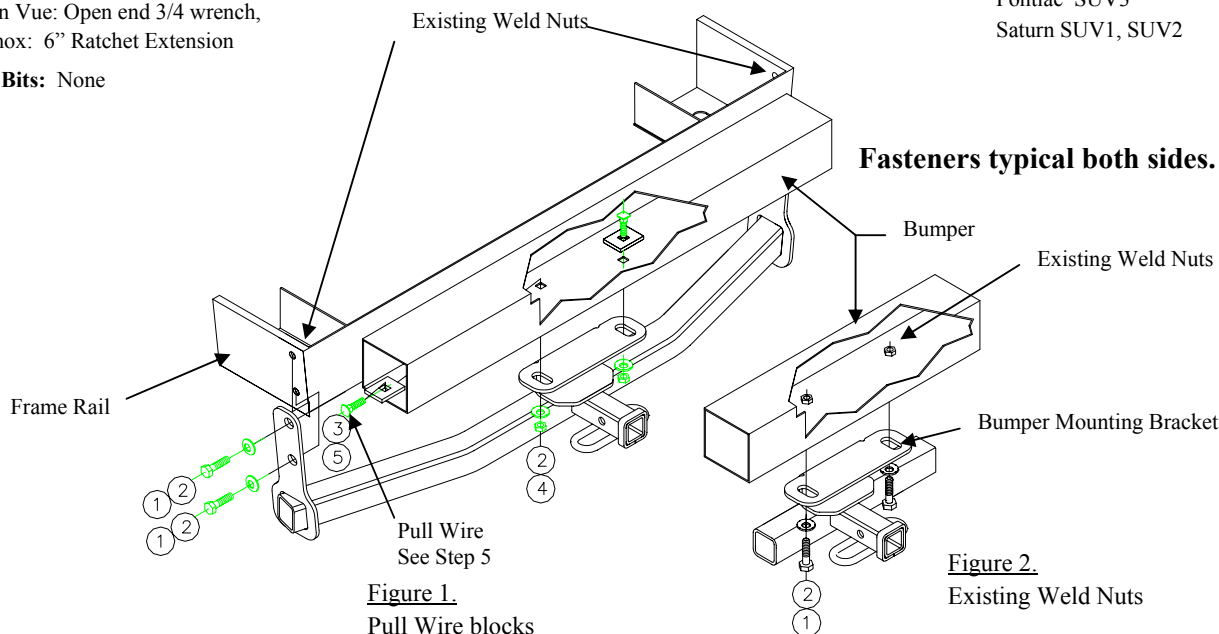

**Figure 1.**  
Pull Wire blocks

**Figure 2.**  
Existing Weld Nuts

①	Qty. (6)	Hex Bolt M12	④	Qty. (2)	Hex Nut 1/2-13
②	Qty. (6)	Conical Washer	⑤	Qty. (2)	Block 1-1/2 X 2
③	Qty. (2)	Carriage Bolt 1/2-13	⑥	Qty. (1)	Pull Wire

1. If present, remove the tie down brackets from vehicle frame rail. Return bolts and tie down bracket to owner.
2. Remove the fascia door on the Equinox.
3. Raise the hitch into position; lifting the bumper mounting bracket over the fascia (where needed). Secure with M12 bolts and conical washers into the existing weld nuts.
4. Hand tighten all bolts.
5. Saturn Vue: Pull carriage bolts and small blocks thru end of the bumper and feed through the bumper mounting bracket using the pull wire. Attach conical washer and nut. As shown Figure 1.  
Chevrolet Equinox, Pontiac Torrent install the M12 bolts and conical washer through the bumper mounting bracket into the existing weld nuts in the bumper, as shown Figure 2.
6. Tighten all 1/2-13 GR5 fastener with torque wrench to 75 Lb.-Ft. Tighten all M12 CL8.8 fasteners with torque wrench to 68 Lb.-Ft.
7. Replace the fascia door on the Equinox.

Note: Due to different configuration of the vehicle there will be extra hardware left over.

Note: check hitch frequently, making sure all fasteners and ball are properly tightened. If hitch is removed, plug all holes in trunk pan or other body panels to prevent entry of water and exhaust fumes. A hitch or ball which has been damaged should be removed and replaced. Observe safety precautions when working beneath a vehicle and wear eye protection. Do not cut access or attachment holes with a torch.