

Installation Instructions

Subaru Legacy Sedan

Subaru Legacy Wagon

Subaru Legacy Outback

Part Numbers:

36284
06287
90176

Optional Drawbar (Sold Separately)
For **Legacy Outback Only** 36053
Drawbar must be used in the **RISE**
Position only.

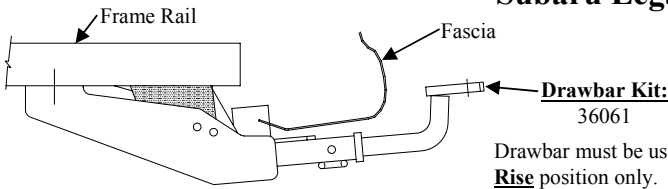

**Do Not Exceed Lower of Towing Vehicle
Manufacturer's Rating or**

3500 LB (1589 Kg) Max Gross Trailer Weight
300 LB (136 Kg) Max Tongue Weight

Wiring Access Location: PC1, PC2

Hitch Shown In Proper Position

Note: Fasteners Typical Both Sides

Equipment Required:

Fastener Kit: K36284

Wrenches: 12mm, 11/16, 3/4, 7/8

Drill Bits: None

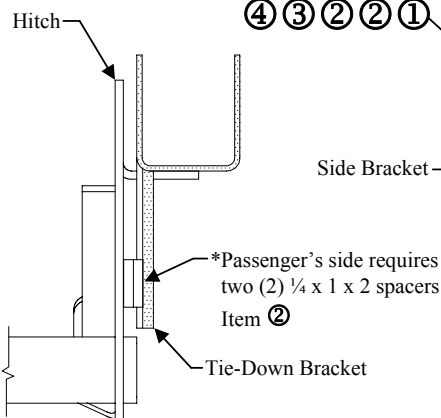

Figure 2

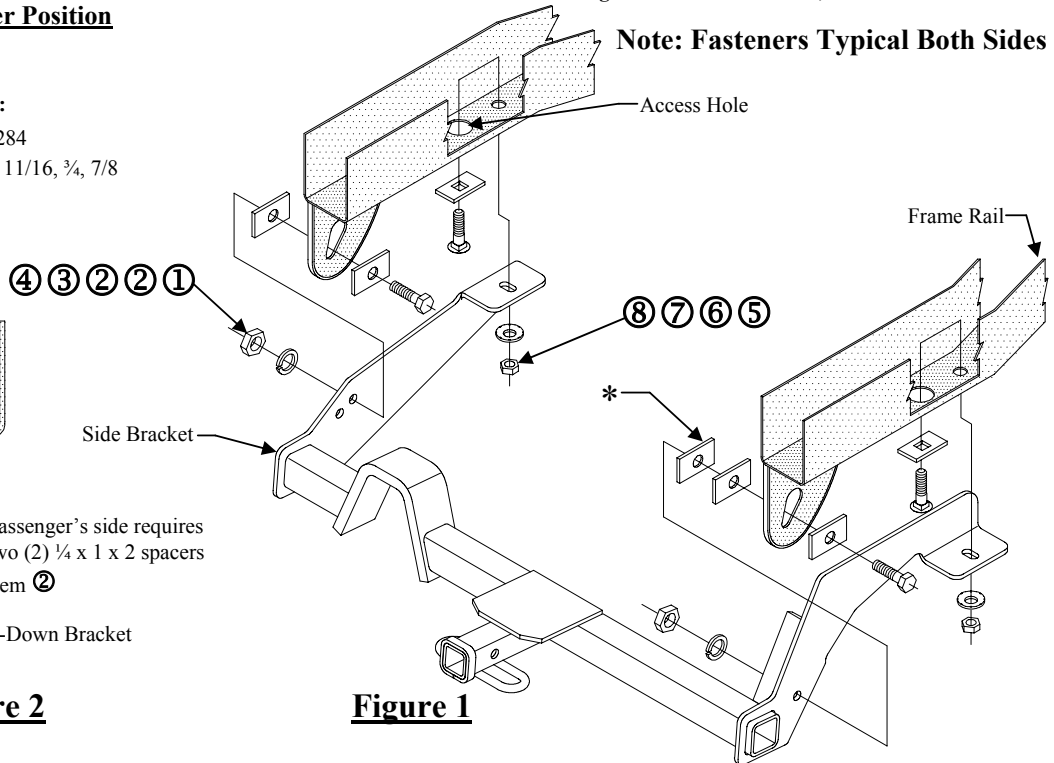

Figure 1

①	Qty. (2)	Hex Bolt 1/2-13 x 2-1/4 GR5	⑤	Qty. (2)	Carriage Bolt 7/16-14 x 1-1/2 GR5
②	Qty. (5)	Spacer 1/4 x 1 x 2	⑥	Qty. (2)	Spacer 1/4 x 1 x 3
③	Qty. (2)	Lockwasher 1/2	⑦	Qty. (2)	Conical Toothed Washer 7/16
④	Qty. (2)	Hex Nut 1/2-13	⑧	Qty. (2)	Hex Nut 7/16-14

- Lower carbon canister and bracket from passenger side frame rail.
- Remove the four (4) plastic caps from bottom of frame rails. Fishwire carriage bolts and blocks through access hole in bottom of frame as shown in Figure 1.
Note: On driver's side, side bracket attaches to the outboard side of the tie-down bracket. On passenger's side, side bracket attaches to the inboard side of the tie-down bracket.
- Raise hitch into position. Loosely install hex nuts and conical toothed washers onto forward most fasteners. Install hex bolts and blocks as shown in Figure 1.
Note: On passenger's side, place additional block between hitch and tie-down bracket. See Figure 2.
- Reinstall large plastic caps into access holes removed in step 2. Reattach carbon canister and bracket.
Tighten all 7/16-14 GR5 fasteners with torque wrench to 50 Lb.-Ft. (68 N*M)
Tighten all 1/2-13 GR5 fasteners with torque wrench to 75 Lb.-Ft. (102 N*M)

Note: check hitch frequently, making sure all fasteners and ball are properly tightened. If hitch is removed, plug all holes in trunk pan or other body panels to prevent entry of water and exhaust fumes. A hitch or ball which has been damaged should be removed and replaced. Observe safety precautions when working beneath a vehicle and wear eye protection. Do not cut access or attachment holes with a torch.