

Installation Instructions

Part Numbers:

Chrysler Sebring, All inc. convertible
Dodge Avenger
Chrysler 200, All inc. convertible

24871
60288
77254

**Do Not Exceed Lower of Towing Vehicle
 Manufacturer's Rating or**

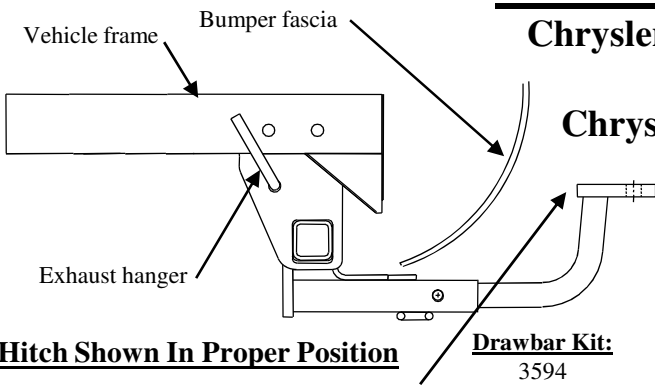

Hitch Shown In Proper Position

Equipment Required:

- Fastener Kit:** 24871F
- Wrenches:** 3/4", 7/8"
- Drill Bits:** None
- Spray lubricant

Drawbar must be used in the **Rise** position only.

Hitch type	Max Gross Trailer WT	Max Tongue WT
Weight Carrying Ball Mount	2000 lb. (908 Kg)	200 lb. (91 Kg)

Wiring Access Location: (Sebring) PC3 & PC4

Wiring Access Location: (Avenger) PC1 & PC2

Wiring Access Location: (200) PC1 & PC2

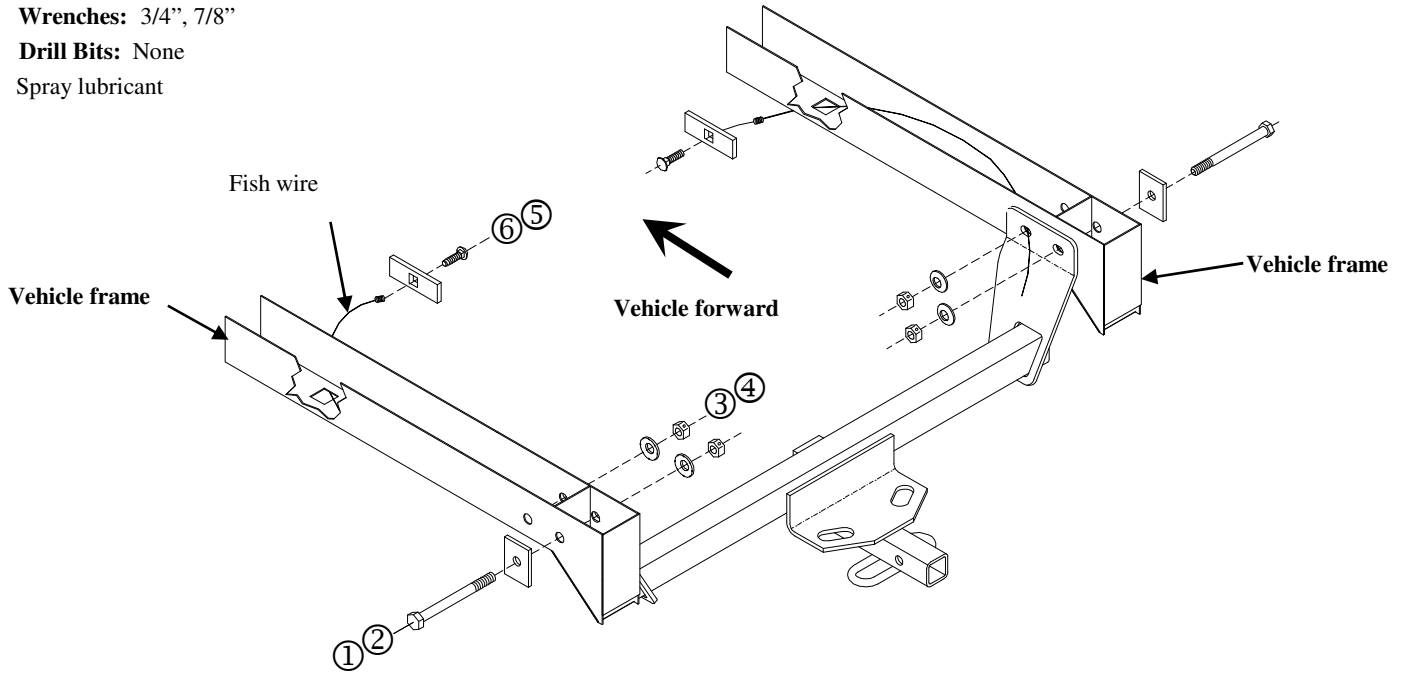

1	Qty. (2)	1/2"-13 X 4-1/2" Gr.5 Hex Bolts	4	Qty. (4)	1/2" Hex nuts
2	Qty. (2)	1/4" X 1-1/2" X 3" Blocks	5	Qty. (2)	1/4" X 1" X 2" Blocks
3	Qty. (4)	1/2" Conical washers	6	Qty. (2)	1/2"-13 X 1-3/4" Gr.5 Carriage Bolts

1. Remove exhaust hangers both sides. Spraying a lubricant on the metal hanger rod and the rubber isolator helps removal.
2. Raise hitch into position and insert 4-1/2" bolts and blocks through frame and hitch - both sides. Install conical washers and 1/2" nuts. Hand tighten only.
3. Use Fishwire (provide) to install Carriage bolt and block through square hole forward on frame. Keep bolt and block separate until inside of frame. Install conical washers and 1/2" nuts. Hand tighten only.
4. Tighten all (4) 1/2" fasteners installed in Step 2 and 3.

Tighten all 1/2" hex bolts with torque wrench to 40 Lb.-Ft.

Tighten all 1/2" carriage bolts with torque wrench to 75 Lb.-Ft.

Note: check hitch frequently, making sure all fasteners and ball are properly tightened. If hitch is removed, plug all holes in trunk pan or other body panels to prevent entry of water and exhaust fumes. A hitch or ball which has been damaged should be removed and replaced. Observe safety precautions when working beneath a vehicle and wear eye protection. Do not cut access or attachment holes with a torch.

Looking for dependable trailer hitches and towing? Rely on Draw-Tite for quality and long-lasting products.