

Installation Instructions

Part Numbers:

24831

77204

60221

Infiniti G35

Infiniti G37

Fascia trimming required. Obtain vehicle owner approval before cutting.

Do Not Exceed Lower of Towing Vehicle Manufacturer's Rating or

2000 LB (908 Kg.) Max Gross Trailer Weight

200 LB (90.8) Max Tongue Weight

Wiring Access Location: PC3, PC4

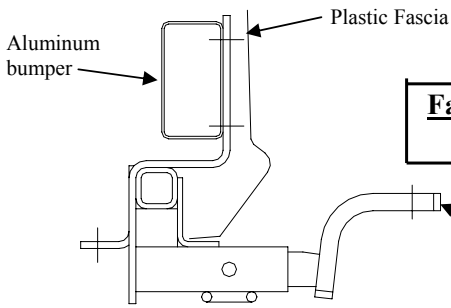

Drawbar Kit:
3593

Drawbar must be used in the **RISE** position only.

Hitch Shown In Proper Position

Equipment Required: Utility Knife

Fastener Kit: 24831N

Wrenches: 13mm, 3/4"

Drill Bits: 3/4"

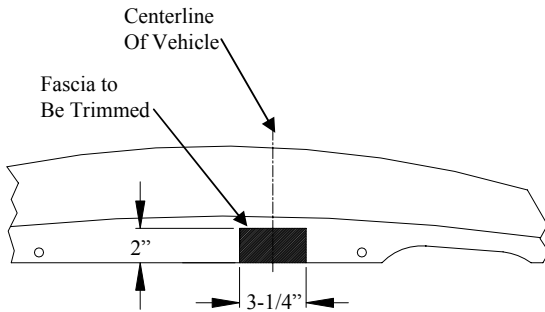
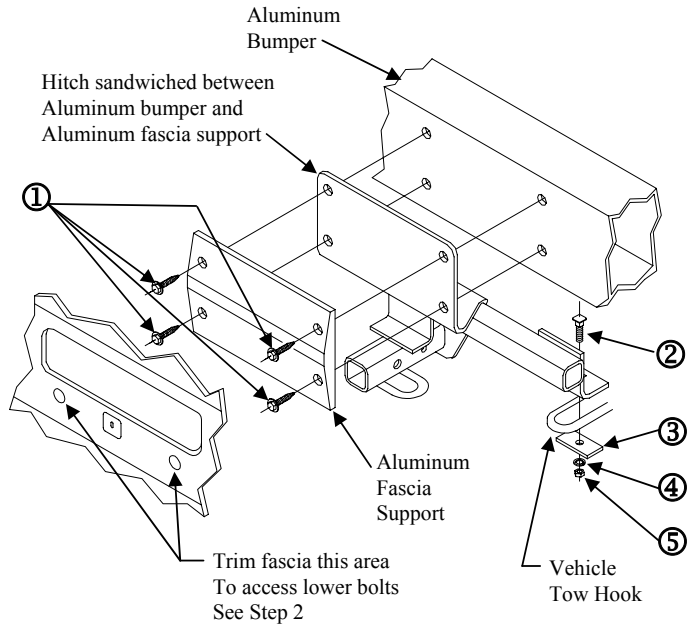

Figure 2
Fascia Trim Detail



Trim fascia this area To access lower bolts See Step 2

①	Qty. (4)	Hex Bolt M8 x 1.25 x 35mm CL9.8	④	Qty. (1)	Lock Washer 1/2"
②	Qty. (1)	Hex Bolt 1/2-13 x 1.75 GR5	⑤	Qty. (1)	Hex Nut 1/2-13
③	Qty. (1)	Spacer 1/4 x 1.50 x 3.00			

Note: Before removing license plate, mark rear fascia at the bottom edge of license plate.

- Remove license plate.
- Using 3/4" drill bit or utility knife, cut access to lower bolts in fascia, behind license plate, such that when license plate is re-attached, access holes will be hidden.
- Remove black appearance panel from under vehicle.
- Cut notch in plastic fascia, approx. 3-1/4" wide x 2" deep as shown in figure 2.
- Remove aluminum fascia support from rear bumper by removing (4) M8 fasteners. Discard fasteners.
- Raise hitch and aluminum fascia support into position by gently pulling fascia rearward to allow access to rear face of aluminum bumper. Attach with M8 Hex Bolts provided with hitch.
Note: Hitch will be installed with hitch angle bracket (with square hole) on top of tow hook. Hitch will be sandwiched between aluminum bumper and aluminum fascia support.
- Install 1/2" fasteners at tow hook attachment as shown.
- Tighten all M8x 1.25 CL9.8 fasteners with torque wrench to 20 Lb.-Ft. (27 N*M)**
Tighten all 1/2-13 GR5 fasteners with torque wrench to 75 Lb.-Ft. (102 N*M)
- Raise black appearance panel and mark area to be trimmed for clearance of hitch.
- Lower appearance panel and trim as marked.
- Raise appearance panel and re-attach.

Note: check hitch frequently, making sure all fasteners and ball are properly tightened. If hitch is removed, plug all holes in trunk pan or other body panels to prevent entry of water and exhaust fumes. A hitch or ball which has been damaged should be removed and replaced. Observe safety precautions when working beneath a vehicle and wear eye protection. Do not cut access or attachment holes with a torch.