

# Installation Instructions

Part Numbers:

**24826**

**77198**

**60218**

## Honda Fit

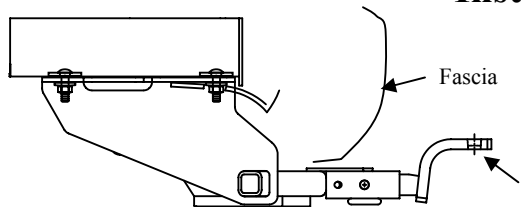

**Drawbar Kit:**  
3593

Drawbar must be used in the **RISE** position only.

**Do Not Exceed Lower of Towing Vehicle  
Manufacturer's Rating or**

**2000 LB (908 Kg.) Max Gross Trailer Weight**

**200 LB (90.8 Kg.) Max Tongue Weight**

### Hitch Shown In Proper Position

**Equipment Required: Screwdriver, Utility knife, Metal file**

**Fastener Kit: 24826F**

**Wrenches: 11/16"**

**Drill Bits: None**

**Wiring Access Location: PC3, PC4**

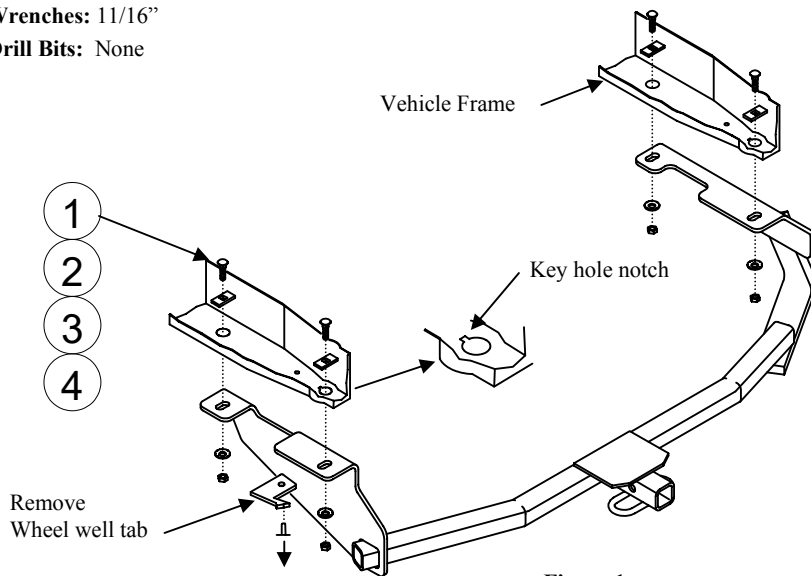

Figure 1.

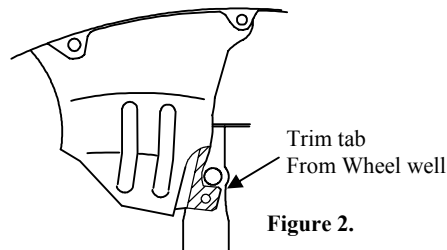

Figure 2.

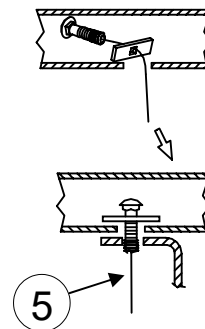

Figure 3.

### Fasteners typical

### Both sides of vehicle

①	Qty. (4)	Carriage Bolt 7/16-14 x 1.50 GR5	④	Qty. (4)	Hex Nut 7/16-14
②	Qty. (4)	Spacer 3/16" x 1 x 2	⑤	Qty. (4)	Pull wire, 7/16
③	Qty. (4)	Conical Toothed Washer 7/16"			

- Remove the retainer holding the wheel well tab to bottom of frame rail on driver's side. Trim wheel well tab so that the hitch side bracket will sit flush against the bottom of frame rail. See figure 2.
- Cut a key hole notch in the rearmost hole in frame, both sides, so that the 1" wide spacer (item 2) will fit inside the frame rail.
- Using pull wires provided, install carriage bolts and spacers into frame rail through the key hole into the forward holes.
- For the rearmost hole, fishwire the carriage bolts and spacer blocks into the rear hole and back down through hole. See figure 3.
- First, raise the passenger's side hitch bracket around the tailpipe, then raise the driver's side of hitch up to frame and onto carriage bolts. **Do not install bracket on top of wheel well tab.**  
Note: Be careful not to push bolts and spacers back into frame.
- Install the conical toothed washers and hex nuts onto carriage bolts.

**Tighten all 7/16-14 GR5 fasteners with torque wrench to 50 Lb.-Ft. (68 N\*M)**

Note: check hitch frequently, making sure all fasteners and ball are properly tightened. If hitch is removed, plug all holes in trunk pan or other body panels to prevent entry of water and exhaust fumes. A hitch or ball which has been damaged should be removed and replaced. Observe safety precautions when working beneath a vehicle and wear eye protection. Do not cut access or attachment holes with a torch.