

Installation Instructions

Toyota Yaris

Part Numbers:

24819

60209

77191

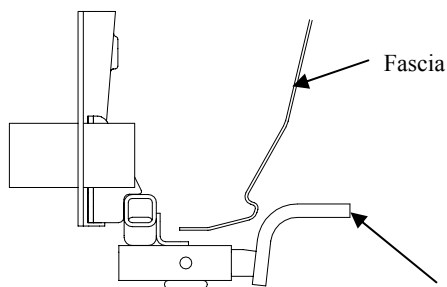

Drawbar must be used in the **RISE** position only.

Do Not Exceed Lower of Towing Vehicle Manufacturer's Rating or

2000 LB (908 Kg) Max Gross Trailer Weight

200 LB (90.8 Kg) Max Tongue Weight

Wiring Access Location: PC3, PC4

Hitch Shown In Proper Position

Equipment Required:

Fastener Kit: 24819F

Wrenches: 12mm, 13mm

Drill Bits: None

Note: Fasteners typical both sides

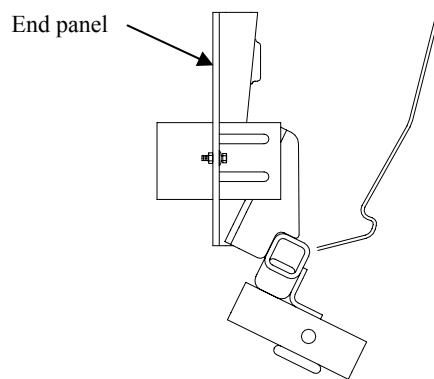
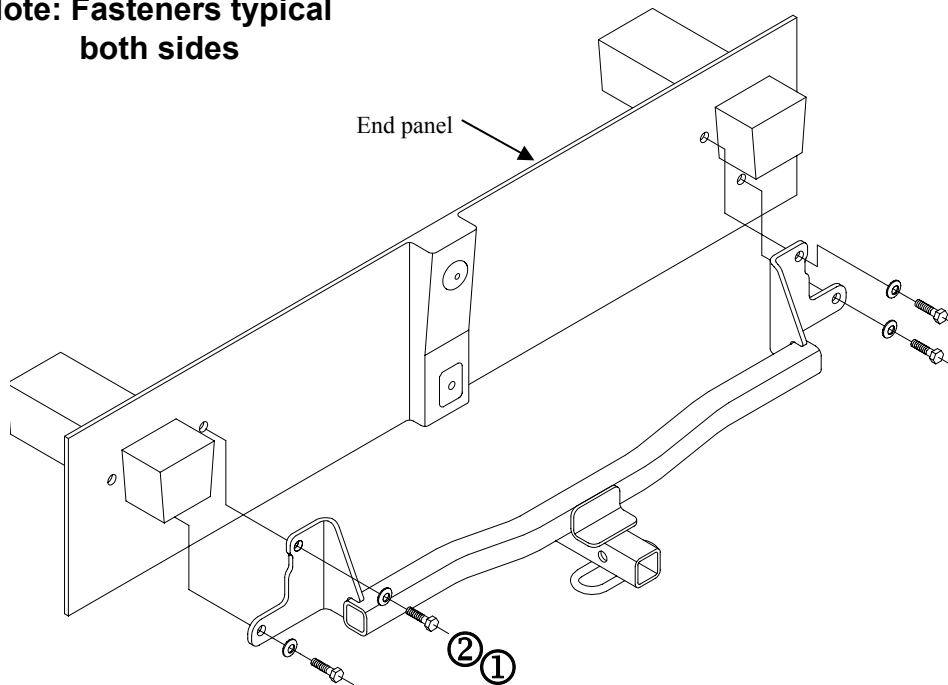

Note: Rotate the hitch for ease of installation.

①

Qty. (4)

M8 x 1.25 x 30mm, CL 10.9

②

Qty. (4)

Conical Toothed Washer

1. Remove the two plastic fascia rivets from the fascia tabs (Do not discard).
2. Remove the vehicle inboard bolt and the lower bolt located on each side of the end panel.
3. Raise hitch into position.
4. Install M8 bolts and conical toothed washers.
5. Re-install the plastic fascia rivets removed in installation Step 1.

Tighten all M8 CL10.9 fasteners with torque wrench to 27 Lb.-Ft (37 N-M).

Note: check hitch frequently, making sure all fasteners and ball are properly tightened. If hitch is removed, plug all holes in trunk pan or other body panels to prevent entry of water and exhaust fumes. A hitch or ball which has been damaged should be removed and replaced. Observe safety precautions when working beneath a vehicle and wear eye protection. Do not cut access or attachment holes with a torch.

Looking for dependable trailer hitches and towing? Rely on Draw-Tite for quality and long-lasting products.