

Installation Instructions

Suzuki SX4 Crossover

Part Numbers:

24817

60202

77189

Drawbar Kit:

3594

Drawbar must be used in the **RISE** position only.

Do Not Exceed Lower of Towing Vehicle Manufacturer's Rating or

2000 LB (908 Kg) Max Gross Trailer Weight

200 LB (90.8 Kg) Max Tongue Weight

Wiring Access Location: SUV 1 & 2

Hitch Shown In Proper Position

Equipment Required: Spray lubricant, Paint, Pull wire (Provided)

Fastener Kit: 24817F

Wrenches: 11/16", 3/4"

Drill Bits: 1" Hole Cut Saw

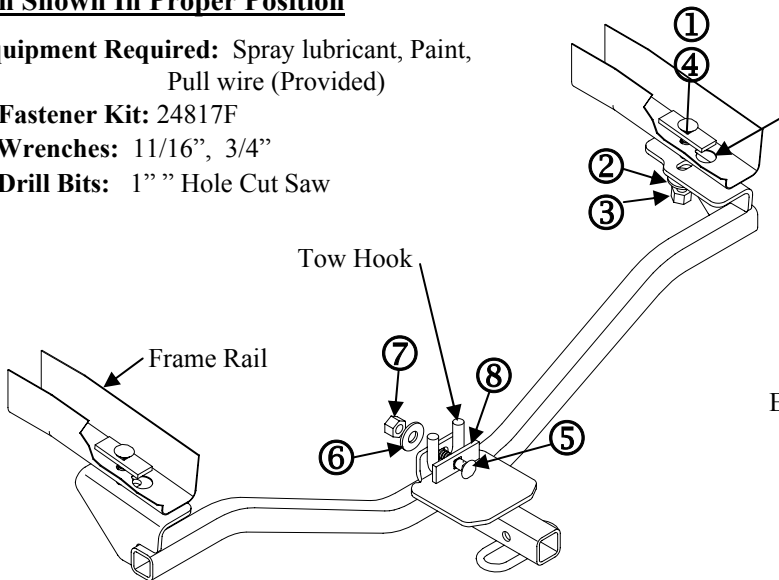

Figure 1

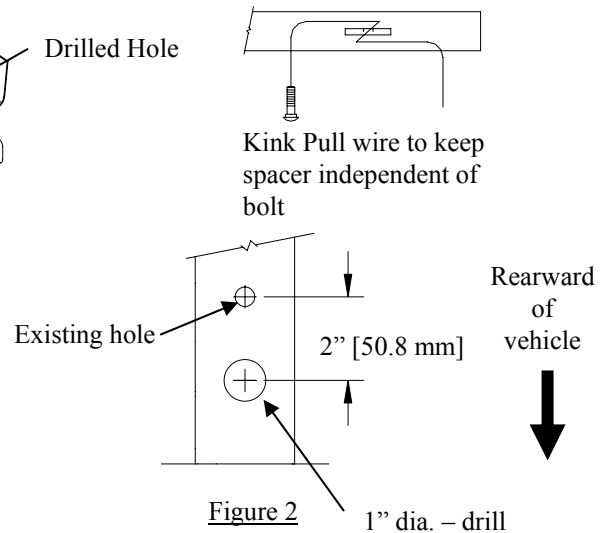

Figure 2
Drilling of Access Holes

Note: Fasteners typical both sides

①	Qty. (2)	Carriage bolt 7/16-14 X 1.50 Gr5	⑤	Qty. (1)	Carriage bolt 1/2-13 X 2.00 Gr5
②	Qty. (2)	Conical washer 7/16	⑥	Qty. (1)	Conical washer 1/2
③	Qty. (2)	Hex nut 7/16-14	⑦	Qty. (1)	Hex nut 1/2-13
④	Qty. (2)	Spacer (small sq holes)	⑧	Qty. (1)	Spacer

- Lower exhaust system at the rubber isolator (3). Spraying a lubricant on the metal hanger rod and the rubber isolator helps removal.
- Drill 1" access hole in bottom of each frame rail. See Figure 2.
- Feed pull wires with spacer and bolt into frame rail thru 1" drilled hole and out the attachment holes. Leave pull wire attached
- Paint any exposed metal.
- Raise hitch into position and attach as shown in Figure 1. Remove pull wires and attach conical washers and nut (be careful not to push fastener back into frame rail). Hand tighten.
- Attach hitch to tow hook as shown in Figure 1. Orient the spacers with respect to the tow hook as shown.
- Check to assure hitch is centered on vehicle.
- Torque all fasteners to specifications.
- Raise exhaust system back into position.

Tighten all 1/2 GR5 fasteners with torque wrench to 75 Lb.-Ft. (102 N*M)

Tighten all 7/16 GR5 fasteners with torque wrench to 50 Lb.-Ft. (68 N*M)

Note: check hitch frequently, making sure all fasteners and ball are properly tightened. If hitch is removed, plug all holes in trunk pan or other body panels to prevent entry of water and exhaust fumes. A hitch or ball which has been damaged should be removed and replaced. Observe safety precautions when working beneath a vehicle and wear eye protection. Do not cut access or attachment holes with a torch.

Looking for dependable trailer hitches and towing? Rely on Draw-Tite for quality and long-lasting products.