

# Installation Instructions

**TOYOTA MATRIX**

**PONTIAC VIBE**

Part Numbers:

**24812**

**60898**

**77183**

**Drawbar Kit:**

3593

Drawbar must be used in the rise position only.

**Do Not Exceed Lower of Towing Vehicle  
Manufacturer's Rating or**

**2000 LB (908 Kg) Max Gross Trailer Weight**

**200 LB (91 Kg) Max Tongue Weight**

**Hitch Shown In Proper Position**

**Wiring Access Location: SUV3, SUV4**

**Equipment Required:**

**Fastener Kit: 24812F**

**Wrenches: 19mm**

**Drill Bits: NONE**

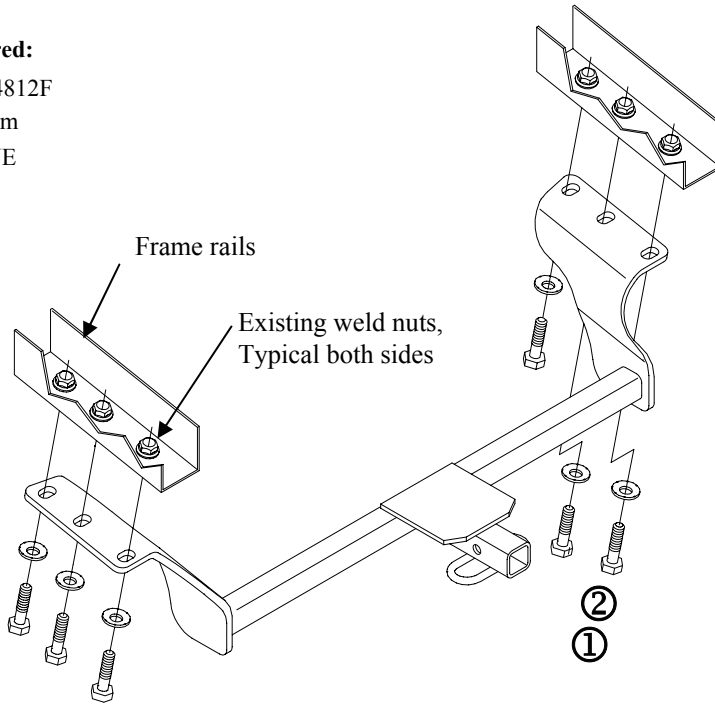

**Note: Fasteners typical both sides**

①	Qty. (6)	Bolt M12 x 1.25 x 40mm CL10.9	②	Qty. (6)	Conical Washer 1/2"
---	----------	-------------------------------	---	----------	---------------------

**Note: Toyota Matrix XRS & XR Sport models have added center fascia that must be removed for hitch installation.**

1. Raise hitch into position.
2. Install fasteners into existing weldnuts as shown above.

Tighten all M12 CL 10.9 fasteners with torque wrench to 92 Lb.-Ft. (125 N\*M)

Note: check hitch frequently, making sure all fasteners and ball are properly tightened. If hitch is removed, plug all holes in trunk pan or other body panels to prevent entry of water and exhaust fumes. A hitch or ball which has been damaged should be removed and replaced. Observe safety precautions when working beneath a vehicle and wear eye protection. Do not cut access or attachment holes with a torch.

Looking for dependable trailer hitches and towing? Rely on Draw-Tite for quality and long-lasting products.