

Installation Instructions

Nissan Altima
Nissan Maxima

Part Numbers:
24796
60873
77168

Drawbar Kit:
3594

Drawbar must be used in the **RISE** position only.

Do Not Exceed Lower of Towing Vehicle Manufacturer's Rating or

2000 LB (908Kg) Max Gross Trailer Weight
200 LB (90.8 Kg) Max Tongue Weight

Wiring Access Location: PC3, PC4

Hitch Shown In Proper Position

Equipment Required: Sealant

Fastener Kit: 24796F

Wrenches: 11/16", 5/8", 16mm

Drill Bits: 7/16"

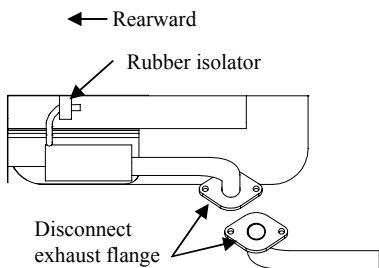
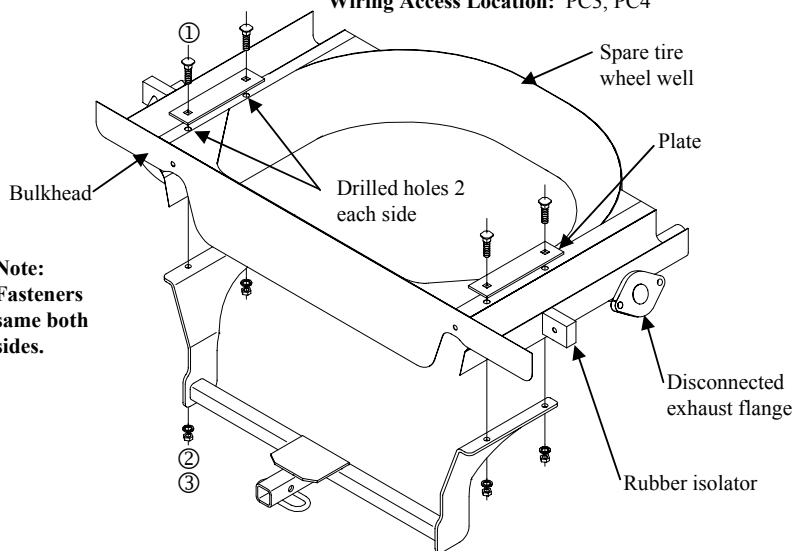

Figure 1.

Note:
Fasteners
same both
sides.



①	Qty. (4)	Carriage bolt 7/16-14 X 1.50 GR5	③	Qty. (4)	Nut 7/16-14
②	Qty. (4)	Lock washer			

- Remove carpeting, fiber board and storage bin tray (if present) from vehicle trunk.
- Remove the ground wire from the drivers side muffler.
- Disconnect the exhaust at the flange. Both sides. Keep the fasteners. Figure 1.
- Push exhaust toward the rear of the vehicle and off the rubber isolator. Gently push the heat shield toward the frame rail exposing the area between the frame rail and wheel well.
- Raise the hitch into position (being careful not to scratch the fascia) between the frame rails and spare tire wheel well. Align the rear edge of the side bracket on the hitch flush against the bulkhead. Check the location of the hitch on the vehicle.
- Using the hitch as a template mark and center punch the (2) holes on both sides.
- Lower hitch. Drill 7/16" hole up through bottom of trunk pan at center punched locations. Check hole alignment under vehicle and adjust if necessary. Remove burrs.
- Position plate over holes inside trunk and insert the carriage bolts through plate and trunk pan (do not install over carpet).
- Raise hitch back into position over carriage bolts and install lock washers and hex nuts as shown. Tighten all 7/16-14 GR5 fasteners to 50 LB-FT.
- Gently bend heat shield back into position. Reattach the exhaust to the rubber isolator and flange. Reattach ground wire to the muffler.
- Apply sealant at bolt attachments inside spare tire well to prevent the intrusion of water and exhaust fumes to vehicle interior.**
- Replace the carpeting, fiber board and storage bin tray (if present).

Tighten all 7/16 GR5 fasteners with torque wrench to 50 Lb.-Ft. (68 N*M)

Note: check hitch frequently, making sure all fasteners and ball are properly tightened. If hitch is removed, plug all holes in trunk pan or other body panels to prevent entry of water and exhaust fumes. A hitch or ball which has been damaged should be removed and replaced. Observe safety precautions when working beneath a vehicle and wear eye protection. Do not cut access or attachment holes with a torch.