

Installation Instructions

Part Numbers:

24775

77152

60846

Mazda 6 - Sedan & 5-Door (does not fit wagons)

Ford Fusion, Mercury Milan, Lincoln Zephyr,

Lincoln MKZ

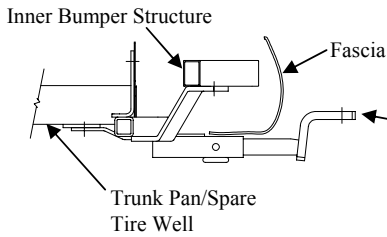

**Do Not Exceed Lower of Towing Vehicle
Manufacturer's Rating or**

2000 LB (908 Kg) Max Gross Trailer Weight

200 LB (90.8Kg) Max Tongue Weight

Hitch Shown In Proper Position

Equipment Required: Pull Wire (Provided)

Fastener Kit: 24775F

Wrenches: 12mm, 13mm, 3/4"

Drill Bits: 1/2"

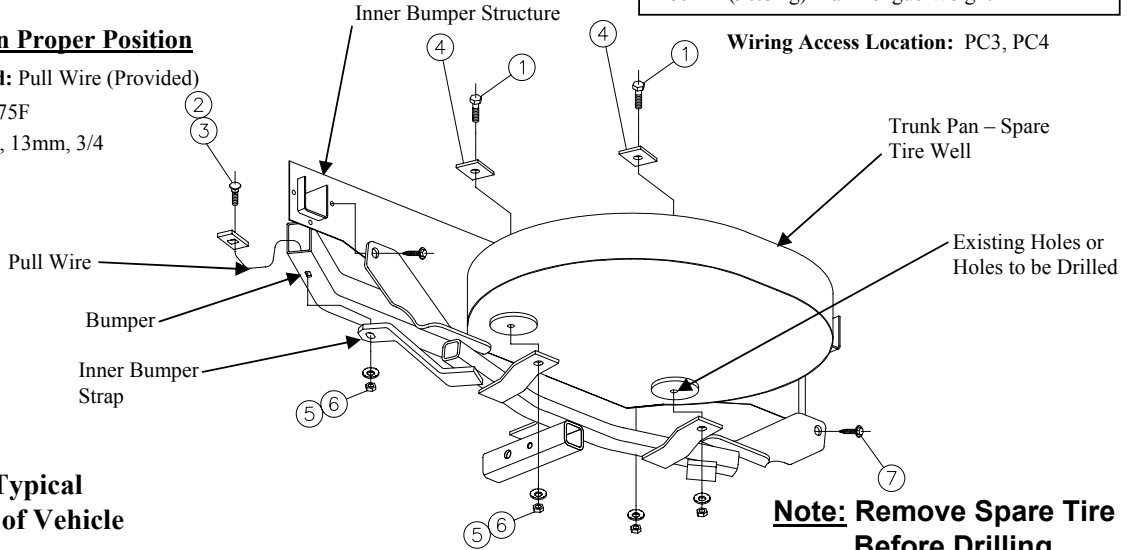

Fasteners Typical Both Sides of Vehicle

①	Qty. (2)	Hex Bolt 1/2-13 x 1-1/2" Gr. 5	⑤	Qty. (4)	Conical Toothed Washer 1/2"
②	Qty. (2)	Carriage Bolt 1/2-13 Gr. 5	⑥	Qty. (4)	Nut 1/2-13
③	Qty. (2)	Block 1/4 x 1 x 2	⑦	Qty. (2)	Bolt M8 x 1.25 x 35mm CL9.8
④	Qty. (2)	Block 3/16 x 1-1/2 x 2			

- Lower muffler by removing (3) rubber isolator hangers, (2) located near the end of the muffler and the remaining hanger forward of the rear axle. Remove (2) rubber plugs from the trunk pan (if present).
- Remove 8mm bolt, located on the inside of the frame rail on the bulkhead, both sides of vehicle. Discard bolts.
- Slide hitch above tailpipes with inner bumper straps sliding under fascia (Note: Care must be taken when sliding inner bumper straps under fascia to prevent scratching). Install 8mm bolts (Item ⑦) loosely thru upright brackets.
- If vehicle bumper has a slots which line up with hole in inner bumper strap, proceed to step 5. If no slots exist, use hitch inner bumper straps as a template to drill (2) 1/2" holes in vehicle bumper.
- Install carriage bolt and block (Item ③) thru inner bumper structure with pull wire, carefully pulling fastener thru existing slot/drilled hole in bumper and hitch. Install conical toothed washer and nut.
Tighten all 1/2-13 GR5 fasteners to 75 lb.-ft. (102 N*M)
Tighten all 8mm fasteners to 25 lb.-ft. (34 N*M)
- Install hex bolt and block (Item ④) thru holes in trunk pan, if present. If holes are not present, **remove spare tire** and use hitch as a template to drill (2) 1/2" holes in trunk pan. Install fasteners as shown.
Tighten all 1/2-13 GR5 fasteners to 75 lb.-ft. (102 N*M)
- Seal holes in trunk pan to prevent intrusion of exhaust fumes or water.
- Reinstall muffler, (3) places.
- Reinstall spare tire in trunk.

Note: check hitch frequently, making sure all fasteners and ball are properly tightened. If hitch is removed, plug all holes in trunk pan or other body panels to prevent entry of water and exhaust fumes. A hitch or ball which has been damaged should be removed and replaced. Observe safety precautions when working beneath a vehicle and wear eye protection. Do not cut access or attachment holes with a torch.