

Installation Instructions

Part Numbers:

Mazda 5

24773

77150

60841

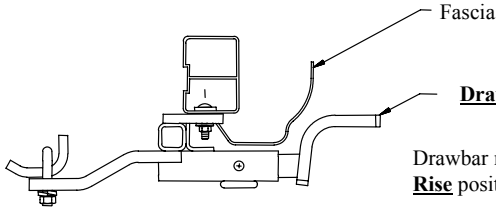

Drawbar must be used in the **Rise** position only.

**Do Not Exceed Lower of Towing Vehicle
Manufacturer's Rating or**

2000 LB (908 Kg) Max Gross Trailer Weight

200 LB (90.8 Kg) Max Tongue Weight

Wiring Access Location: PC3, PC4

Hitch Shown In Proper Position

Equipment Required:

Fastener Kit: 24773F

Wrenches: 11/16, 3/4

Drill Bits: 1/2"

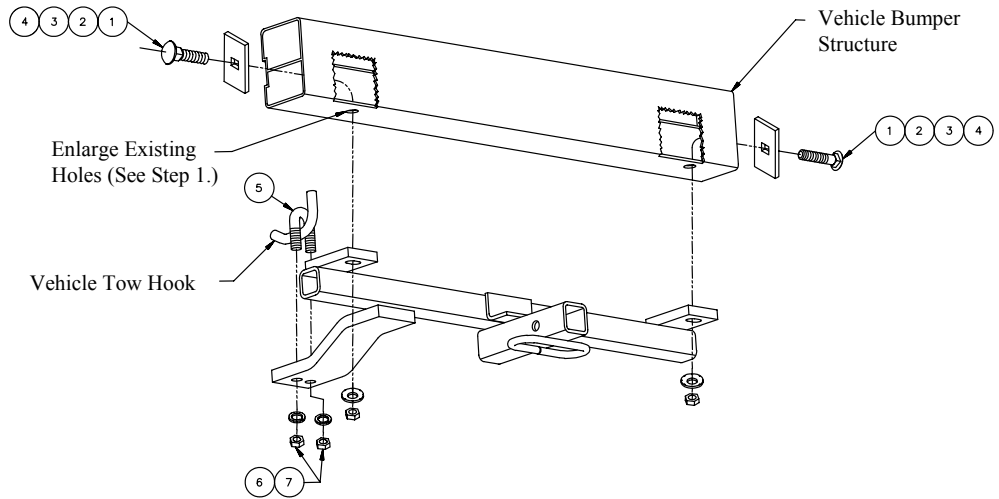

①	Qty. (2)	1/2-13 X 1.50 Carriage Bolt	⑤	Qty. (1)	3/8-16 U-Bolt
②	Qty. (2)	1/4 X 1.00 X 3.00 Block	⑥	Qty. (2)	Lock Washer
③	Qty. (2)	Conical Toothed Washer	⑦	Qty. (2)	3/8 Hex Nut
④	Qty. (2)	1/2 Hex Nut			

1. Enlarge existing holes on the bottom surface of the vehicle bumper structure with a 1/2" drill bit.
2. Fishwire carriage bolts and blocks through the vehicle bumper structure and through the 1/2 drilled holes in in step 1.
3. Raise hitch into position and loosely install the conical toothed washers and 1/2 hex nuts.
4. Install the 3/8 U-Bolt through the vehicle tow hook and through the tow hook attachment of the receiver. Install lock washers and 3/8 hex nuts as shown above.
5. Tighten all remaining fasteners to the required torque specifications.

Tighten all 3/8-16 GR5 fasteners with torque wrench to 30 Lb.-Ft. (41 N*M)

Tighten all 1/2-13 GR 5 fasteners with torque wrench to 75 Lb.-Ft. (102 N*M)

Note: check hitch frequently, making sure all fasteners and ball are properly tightened. If hitch is removed, plug all holes in trunk pan or other body panels to prevent entry of water and exhaust fumes. A hitch or ball which has been damaged should be removed and replaced. Observe safety precautions when working beneath a vehicle and wear eye protection. Do not cut access or attachment holes with a torch.