

# Installation Instructions

Part Numbers:

<b>Chevrolet <i>HHR</i> including <i>SS*</i>, Chevrolet <i>Cobalt SS</i> sedan &amp; coupe &amp; <i>SS</i></b>	<b>24756</b>
<b><i>Supercharged</i>, <i>Cobalt Sport</i> sedan &amp; coupe, Saturn <i>Ion Redline</i> &amp; <i>Ion 3</i></b>	<b>77132</b>
<b>w/2.4L Engine, Pontiac <i>Pursuit GT</i> sedan &amp; coupe &amp; Pontiac <i>G5 GT</i>.</b>	<b>60815</b>

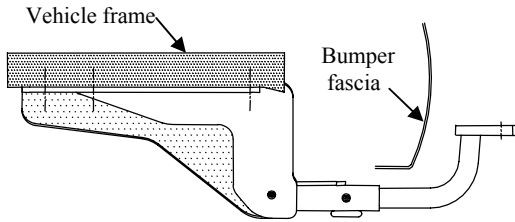

**Hitch Shown In Proper Position**

**Equipment Required:**

**Fastener Kit:** 24756F or 60815F

**Wrenches:** 3/4"

**Drill Bits:** 1/2"

**Drawbar Kit:**

3594 or 6805

Drawbar must be used in the **RISE** position only.

**Do Not Exceed Lower of Towing Vehicle  
Manufacturer's Rating or**

**2000 LB Max Gross Trailer Weight**

**200 LB Max Tongue Weight**

**Wiring Access Location:**

**HHR**-----SUV 3 & 4

**COBALT 2 Drs. PC3&PC4 --4 Drs. PC1&PC2**

**ION**-----PC3 & PC4

**PURSUIT & G5 GT**-----PC1 & PC2

This is the location of the slot for the Cobalt, Ion, Pursuit & G5 GT, typical both sides. See note below.

This is the location of the slot for the HHR, typical both sides. See note below.

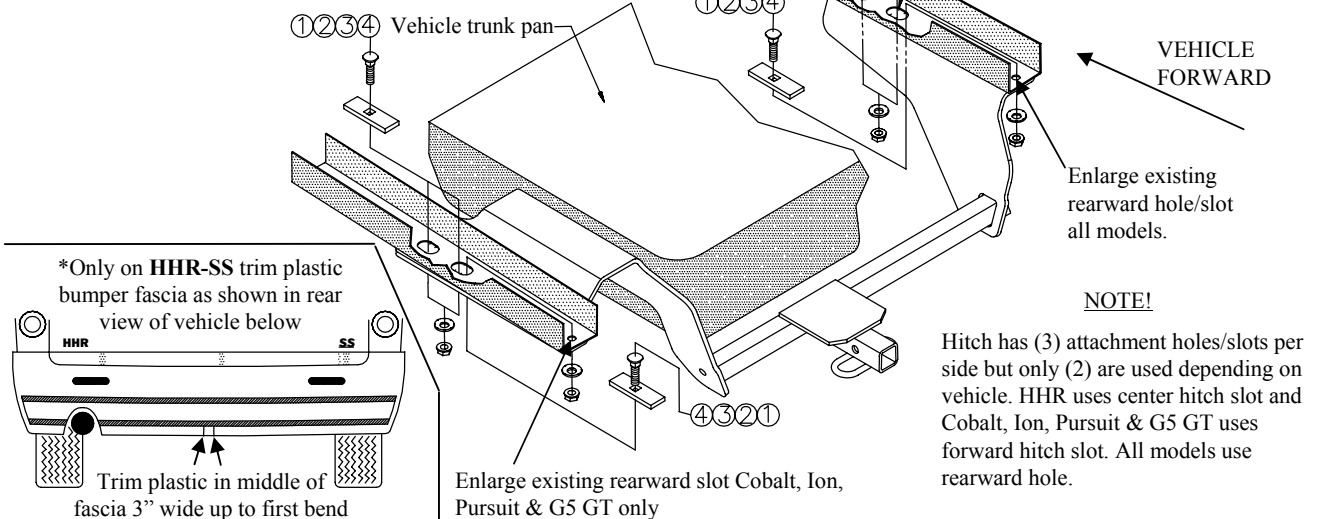

**NOTE!**

Hitch has (3) attachment holes/slots per side but only (2) are used depending on vehicle. HHR uses center hitch slot and Cobalt, Ion, Pursuit & G5 GT uses forward hitch slot. All models use rearward hole.

<b>①</b>	Qty.(4)	1/2"-13 X 1-1/2" Carriage Bolt	<b>③</b>	Qty.(4)	1/2" Conical washer
<b>②</b>	Qty.(4)	1/4" X 1" X 3" Block	<b>④</b>	Qty.(4)	1/2" Hex nut

1. Drop muffler and tailpipe by removing all rubber isolators, behind rear axle, off of hangers. There will be (2) or (3) depending on vehicle. On Ion Redline rearward isolator hanger needs to be bent down slightly for fastener clearance.
2. Install rearward fasteners. On Cobalt, Pursuit, G5 GT and Ion vehicles it will be necessary to drill both rear holes. Use rearmost slot that does not go all the way thru frame as guide to drill clearance hole for 1/2" bolts. On HHR it is necessary to enlarge rearmost slot on passenger side only. Fishwire 1/2" carriage bolts and blocks thru access slots in bottom of frame both sides.
3. Install forward fasteners both sides. Insert carriage bolts and blocks into access slot and drop back down thru slot making sure block spans both sides of slot.
4. While holding muffler down slide hitch up and over muffler and into place making sure that you do not push fasteners back up into frame. Install conical washers and hex nuts on all (4) bolts and do not tighten.
5. Before tightening bolts slide hitch over towards the passenger's side and up against trunk pan. While holding hitch against trunk pan tighten bolts.
6. Tighten all 1/2" fasteners with torque wrench to 75 Lb.-Ft.
7. Reinstall muffler isolator hangers. Tighten all 1/2" fasteners with torque wrench to 75 Lb.-Ft.