

Installation Instructions

Part Numbers:

Acura TL

24755

77131

60814

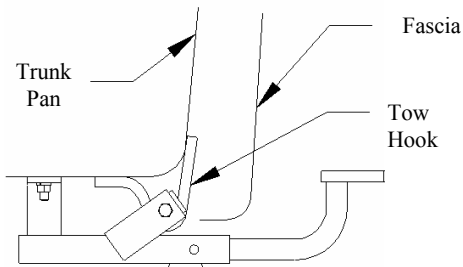

Drawbar Kit:

3594

Or

6809

Drawbar must be used in the **RISE** position only.

Do Not Exceed Lower of Towing Vehicle Manufacturer's Rating or

2000 LB Max Gross Trailer Weight

200 LB Max Tongue Weight

Wiring Access Location: PC3, PC4

Hitch Shown In Proper Position

Equipment Required:

Fastener Kit: 24755F or 60814F

Wrenches: 3/4", 10mm

Drill Bits: 1/2"

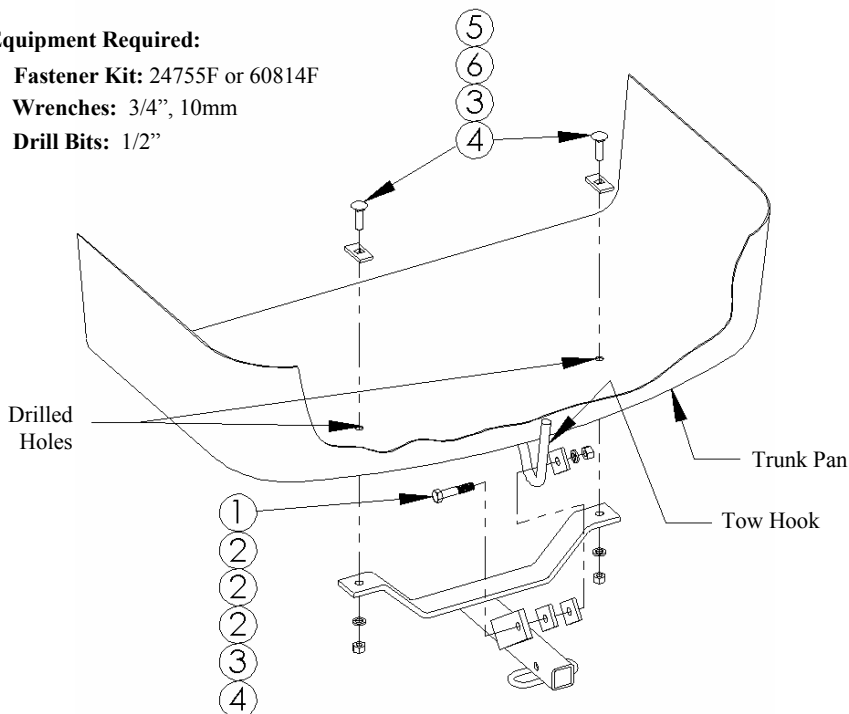

Figure 1

REMOVE SPARE TIRE BEFORE DRILLING

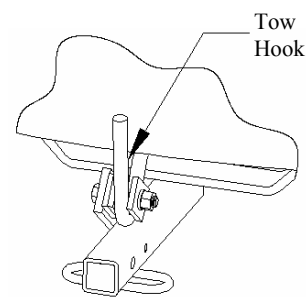
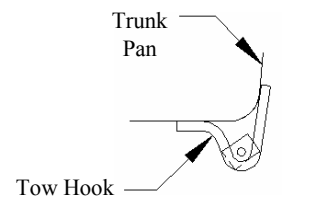

Figure 2



Orient Spacers As Shown

Figure 3

①	Qty. (1)	Hex Bolt, 1/2"-13 x 2-1/2"	④	Qty. (3)	Hex Nut, 1/2"
②	Qty. (3)	Spacer, 1/4" x 1-1/2" x 2"	⑤	Qty. (2)	Carriage Bolt, 1/2"-13 x 1-3/4"
③	Qty. (3)	Lock Washer, 1/2"	⑥	Qty. (2)	Spacer, 1/4" x 1" x 2"

- Remove the spare tire from the trunk.
- Remove plastic cover under trunk by removing four plastic rivets connecting it to the fascia and two hex flange nuts connecting it to the trunk bottom. Reinstall the rivets and return the plastic cover and hex flange nuts to the vehicle owner.
- Attach hitch to tow hook as shown in Figure 1. Orient the spacers with respect to the tow hook as shown in Figure 2 and Figure 3.
- Using the hitch as a template, drill two 1/2" holes in the trunk pan.
- Install the hitch to the trunk pan with the carriage bolts, spacers, lock washers and nuts as shown in Figure 1.
- Seal the holes drilled in the trunk pan to prevent intrusion of exhaust fumes and water.
- Reinstall the spare tire in the trunk.