

# Installation Instructions

## Chevrolet Cobalt Pontiac G5 Pontiac Pursuit (Canada Only)

**Note: Does not fit Cobalt SS Coupe,  
Pursuit GT or G5 GT Models**

Part Numbers:

**24745**

**77122**

**60808**

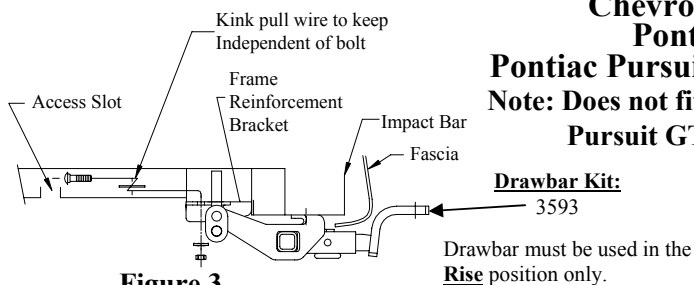

**Figure 3**

**Example of Fishwire Procedure  
Hitch Shown In Proper Position**

**Equipment Required: Drill, Pull Wire (Provided)**

**Fastener Kit: 24745F**

**Wrenches: 3/4"**

**Drill Bits: 1/2"**

**Note: If vehicle is equipped with plastic appearance panel behind trunk pan, it will need to be removed and returned to vehicle owner for hitch installation.**

**Do Not Exceed Lower of Towing Vehicle  
Manufacturer's Rating or**

**2000 LB (908 Kg) Max Gross Trailer Weight**

**200 LB (90.8 Kg) Max Tongue Weight**

**Wiring Access Location: PC1, PC2**

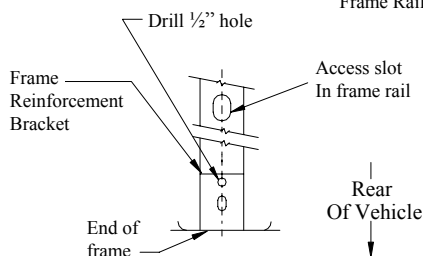

**Figure 2**  
**Drill Location**  
**Typical Both Sides**

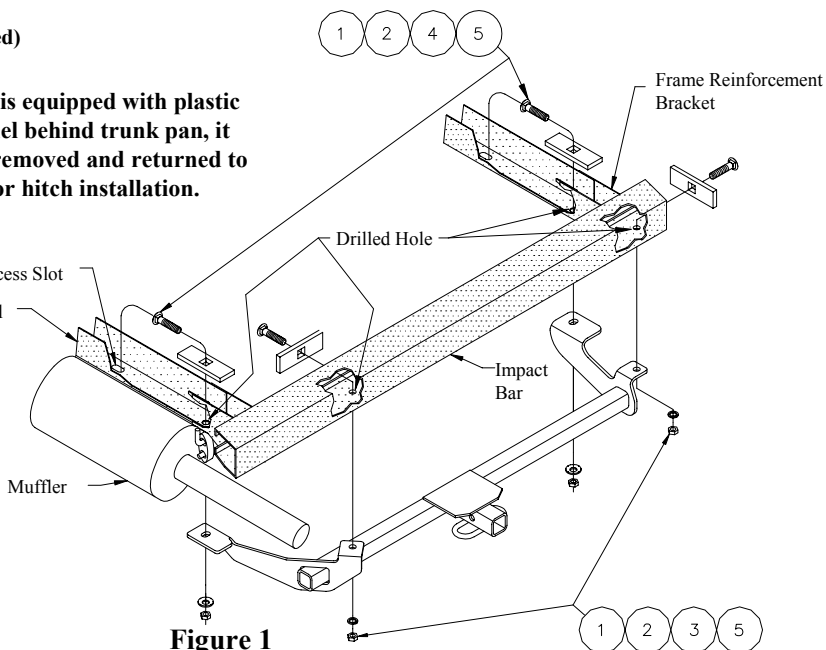

**Figure 1**

①	Qty. (4)	Carriage Bolt – 1/2-13 x 1.75	④	Qty. (2)	Conical Washer – 1/2"
②	Qty. (4)	Spacer – 1/4 x 1 x 3	⑤	Qty. (4)	Hex Nut – 1/2-13
③	Qty. (2)	Lock Washer – 1/2"			

- Lower exhaust by detaching it from the rubber isolator.
- Locate 3/8" hole in frame reinforcement bracket which is welded to frame rail (see Figure 2). Center punch and drill 1/2" hole in frame rail, enlarging 3/8" hole in frame reinforcement bracket to 1/2", both sides.
- Fishwire spacer and carriage bolt thru access slot in frame rail and down thru hole drilled in Step 2, both sides. Use a kink in the wire due to tight area (as shown in Figure 3).
- Raise hitch into position, taking care not to push carriage bolts back into frame. Secure with conical washers and nuts.  
**Note: If vehicle is equipped with plastic appearance panel behind trunk pan, remove and return to vehicle owner.**
- Make sure hitch is centered on vehicle. Using hitch as a template, drill (2) 1/2" holes into vehicle impact bar.
- On driver's side, install carriage bolt and spacer from open face of impact bar and down thru hole drilled in step 5. Secure with lock washer and nut.
- On passenger's side, fishwire carriage bolt and spacer thru end of impact bar and down thru hole drilled in step 5. Secure with lock washer and nut.
- Tighten all 1/2-13 GR5 fasteners with torque wrench to 75 LB.-FT. (102 N\*M)
- Raise exhaust back into position and reattach to rubber isolator.

Note: check hitch frequently, making sure all fasteners and ball are properly tightened. If hitch is removed, plug all holes in trunk pan or other body panels to prevent entry of water and exhaust fumes. A hitch or ball which has been damaged should be removed and replaced. Observe safety precautions when working beneath a vehicle and wear eye protection. Do not cut access or attachment holes with a torch.