

INSTALLATION INSTRUCTIONS

VEHICLE
HONDA CIVIC

EQUIPMENT REQUIRED:

WIRING ACCESS LOCATION: PC3

DRILL BITS: 1-1/8" DIA.

HITCH REQUIRES 1/2" PIN AND CLIP

WRENCHES: (TIGHTEN ALL FASTENERS WITH TORQUE WRENCH) 9/16, 7/8

2000 LB MAX GROSS TRAILER WT
200 LB MAX TONGUE WEIGHT
DO NOT EXCEED TOWING VEHICLE RATINGS

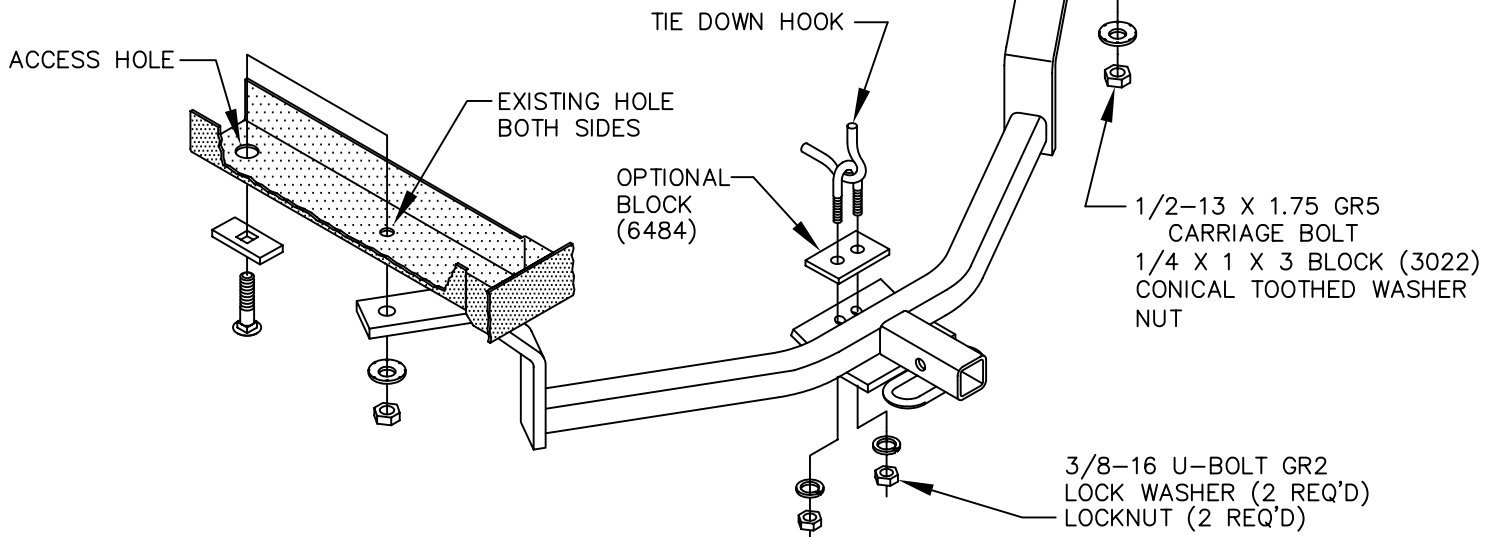
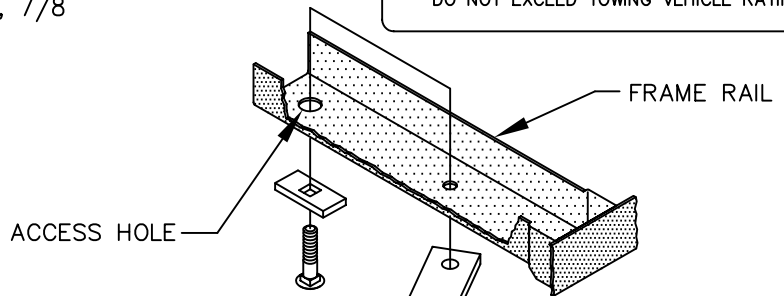
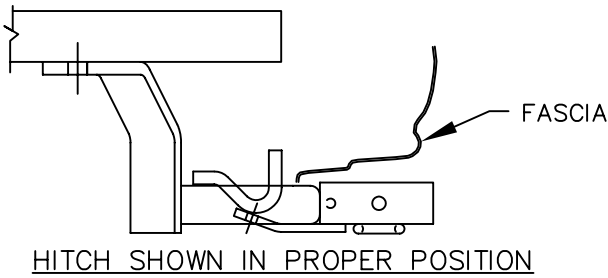

1. ENLARGE EXISTING 15/16" DIAMETER ACCESS HOLE IN BOTTOM OF FRAME RAIL TO 1-1/8" DIAMETER TO ALLOW INSTALLATION OF BLOCKS INTO FRAME.
2. FISHWIRE CARRIAGE BOLT AND BLOCK (3022) THROUGH ACCESS HOLE IN FRAME RAIL BOTH SIDES AS SHOWN.
3. RAISE HITCH INTO POSITION AND INSTALL CONICAL TOOTHED WASHERS AND HEX NUTS ON FORWARD ATTACHMENTS.
4. INSTALL 3/8" U-BOLT THROUGH TOW HOOK AND HITCH BRACKET AS SHOWN ABOVE. USE BLOCK (6484) IF NEEDED SO THAT RECEIVER TUBE IS LEVEL OR TILTED SLIGHTLY UPWARD.
5. PAINT BARE METAL AROUND EDGE OF ACCESS HOLE.

TIGHTEN ALL 3/8 GR2 FASTENERS TO 20 LB.-FT.
TIGHTEN ALL 1/2 GR5 FASTENERS TO 75 LB.-FT.

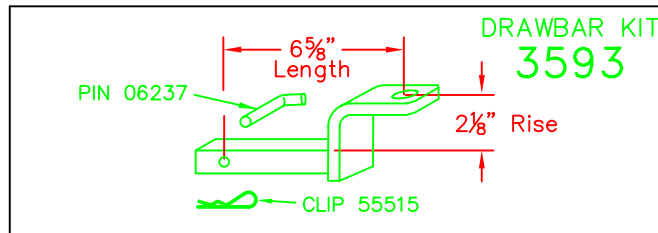

USE ONLY THE DRAWBAR SHOWN FOR CORRECT BUMPER CLEARANCE AND HEIGHT.
DRAWBAR MUST BE USED IN THE RISE POSITION ONLY.

APPROX WEIGHT (LB.)	FASTENER KIT
28	F24706

NOTE: Check hitch frequently, making sure all fasteners and ball are properly tightened. If hitch is removed, plug all holes in trunk pan or other body panels to prevent entry of water and exhaust fumes. A hitch or ball which has been damaged should be removed and replaced. Observe safety precautions when working beneath a vehicle and wear eye protection. Follow car maker's specs for maximum trailer weight and tongue weight. Do not cut access or attachment holes with a torch.