

Installation Instructions

Part Numbers:

**FORD FOCUS SEDAN,
FORD FOCUS 5 DR – ZX5 (HATCHBACK)
FORD FOCUS 3 DR – ZX3 (HATCHBACK)**

24692

77114

60870

Note: Does NOT fit models with Street Appearance Package

Drawbar Kit:
3593

**Do Not Exceed Lower of Towing Vehicle
Manufacturer's Rating or**

2000 LB (908Kg) Max Gross Trailer Weight

200 LB (90.8Kg) Max Tongue Weight

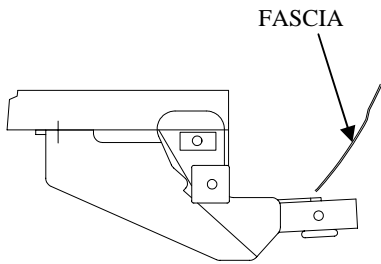

Hitch Shown In Proper Position

Equipment Required:

Fastener Kit: K24692

Wrenches: 3/4", 7/8"

Drill Bits: 1/2"

EXISTING HOLE ON SEDAN, DRILL 1/2" DIA.
HOLE ON HATCHBACK MODELS

Wiring Access Location: PC3, PC4 (SEDAN)
PC1, PC2 (HATCHBACK)

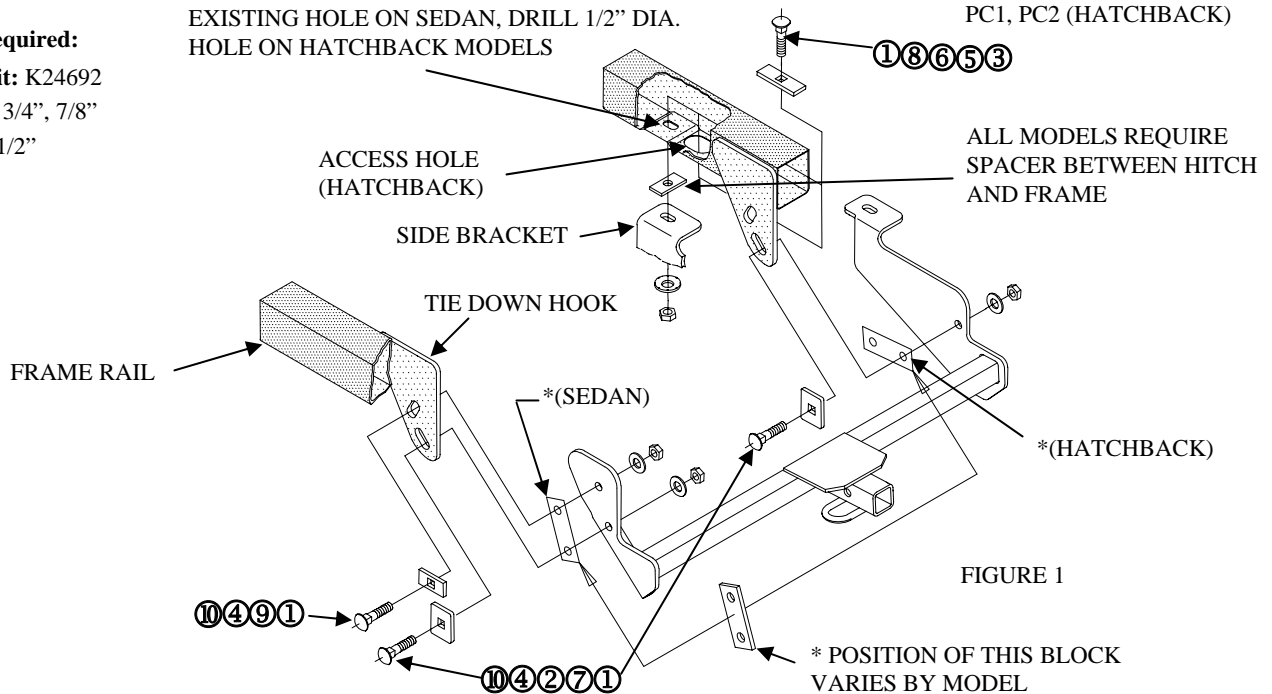

FIGURE 1

| | | | | | |
|---|----------|-----------------------------------|---|----------|----------------------------|
| ① | Qty. (4) | BOLT – CARRIAGE 1/2-13 X 2.00 GR5 | ⑥ | Qty. (1) | BLOCK – .188 X 1.00 X 2.00 |
| ② | Qty. (1) | BLOCK - .25 X 1.50 X 4.00 * | ⑦ | Qty. (2) | BLOCK - .25 X 1.50 X 2.00 |
| ③ | Qty. (1) | NUT – 1/2-13 | ⑧ | Qty. (1) | BLOCK - .25 X 1.00 X 3.00 |
| ④ | Qty. (3) | WASHER – FLAT 1/2" | ⑨ | Qty. (1) | BLOCK - .25 X 1.00 X 2.00 |
| ⑤ | Qty. (1) | WASHER – CONICAL 1/2" | ⑩ | Qty. (3) | NUT – LOCK 1/2-13 |

1. RAISE HITCH INTO POSITION.

NOTE: THE DRIVER'S SIDE BRACKET IS POSITIONED INBOARD OF THE TIE DOWN HOOK, PASSENGER'S SIDE BRACKET IS POSITIONED OUTBOARD OF THE TIE DOWN HOOK.

NOTE: PLACEMENT OF THE BLOCK WITH 2 HOLES VARIES BY MODEL. SEE FIGURE 1.

2. INSTALL CARRIAGE BOLTS AND BLOCKS THRU VEHICLE TIE DOWN HOOKS AS SHOWN AND LOOSELY INSTALL FLAT WASHERS AND HEX NUTS.

SEDAN MODEL:

3. FISHWIRE CARRIAGE BOLT AND BLOCK THRU END OF FRAME RAIL AND INTO EXISTING HOLE IN FRAME.

4. INSTALL REMAINING FASTENERS AS SHOWN.

HATCHBACK:

3. USING THE HITCH AS A TEMPLATE, DRILL 1/2" HOLE IN THE FORWARD MOST END OF SLOT IN SIDE BRACKET ON PASSENGER SIDE.

4. FISHWIRE CARRIAGE BOLT AND BLOCK THRU ACCESS HOLE ON THE BOTTOM OF FRAME RAIL.

5. INSTALL REMAINING FASTENERS AS SHOWN.

Tighten all 1/2" fasteners with torque wrench to 75 Lb.-Ft. (102 N*M)

Note: check hitch frequently, making sure all fasteners and ball are properly tightened. If hitch is removed, plug all holes in trunk pan or other body panels to prevent entry of water and exhaust fumes. A hitch or ball which has been damaged should be removed and replaced. Observe safety precautions when working beneath a vehicle and wear eye protection. Do not cut access or attachment holes with a torch.