

Installation Instructions

Part Numbers:

Ram Promaster

Except Extended Model

75882

87655

44706

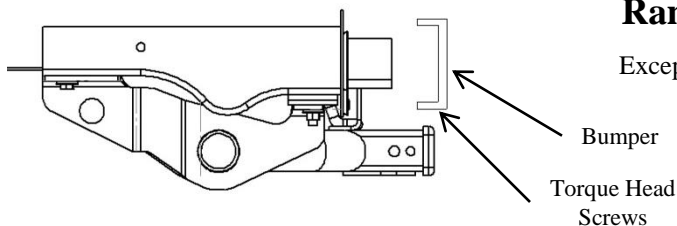

**Do Not Exceed Lower of Towing Vehicle
Manufacturer's Rating or**

Hitch Type	Max Gross Trailer WT (LB)	Max Tongue WT (LB)
Weight Distribution	7500	750
Weight Carrying Ball Mount	6000	750

Hitch Shown In Proper Position

Equipment Required: N/A

Fastener Kit: 75882F

Wrenches: 16mm, 3/4", T-30

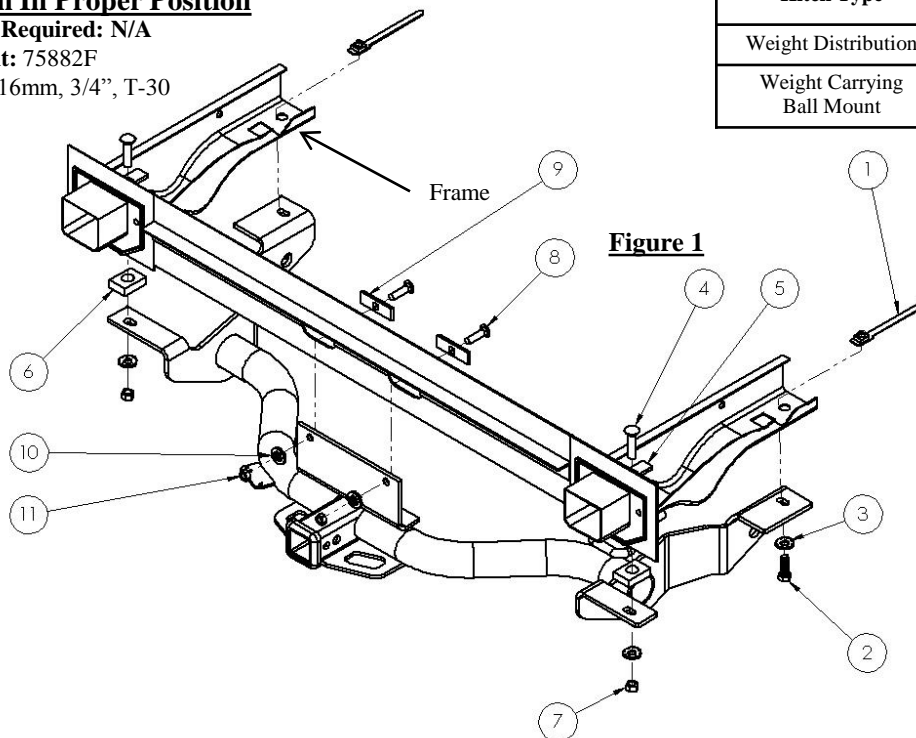

Accessory Rating	D
------------------	----------

Wiring Access Location: SUV 3&4

**Note: Fasteners typical
both sides of hitch.**

①	Qty. (2)	1/2"-13 nut plate	⑧	Qty. (2)	7/16"-14 x 1.75 Carriage Bolt
②	Qty. (2)	1/2"-13 X 1.50 GR5 Hex Bolt	⑨	Qty. (2)	1/4" X 3.00 X 1.00 Spacer Block
③	Qty. (4)	1/2" Conical Washer	⑩	Qty. (2)	7/16" Conical Washer
④	Qty. (2)	1/2"-13 X 2.25 Gr. 5 Carriage Bolt	⑪	Qty. (2)	7/16"-14 Hex Nut
⑤	Qty. (4)	1/4" X 3.00 X 1.00 Spacer Block	⑫	Qty. (2)	1/2" Fish Wire
⑥	Qty. (2)	5/8" X 2.0 X 1.5 Spacer Block	⑬	Qty. (2)	7/16" Fish Wire
⑦	Qty. (2)	1/2"-13 Hex Nut			

- Lower spare tire.
- Remove (8) torque head screws (4 on top, 4 on bottom) which attaches the bumper fascia to the bumper under structure.
- Raise hitch into place as shown.
(Hint, raise one side of the forward attachment above leaf spring, then repeat on the other side)
- Slide nut plate into the frame from the front of the vehicle as shown and hand tighten 1/2" bolts into place.
- Remove rubber grommets and using the fish wire insert the two 7/16" bolts and two 1/2" bolts into their respective position.
- Attach middle 7/16" bolts to hitch and hand tighten.
- Slide 5/8" spacer blocks into place and pass 1/2" bolt through block and vehicle rearward slot as shown. Hand tighten.
- Tighten all hitch fasteners to the torque specifications given.
Tighten all 7/16"-14 Gr. 5 fasteners with torque wrench to 50 Lb.-Ft. (68 N*M)
Tighten all 1/2"-13 Gr. 5 fasteners with torque wrench to 75 Lb.-Ft. (102 N*M)
- Reinstall bumper fascia and raise spare tire into place

Note: Check hitch frequently, making sure all fasteners and ball are properly tightened. If hitch is removed, plug all holes in trunk pan or other body panels to prevent entry of water and exhaust fumes. A hitch or ball which has been damaged should be removed and replaced. Observe safety precautions when working beneath a vehicle and wear eye protection. Do not cut access or attachment holes with a torch.