

Installation Instructions GOOSENECK MOUNTING KIT

Part Numbers:

4454

Chevrolet/GMC 1500 Short & Long Bed
2500 Light Duty Short Bed

Equipment Required:

Fastener Kit: 4454F

Wrenches: 3/4, 15/16, 13mm

Drill Bits: 1/4"

Other Tools: Drill, Saber Saw

WARNING: Under no circumstances do we recommend exceeding the towing vehicle manufacturers recommended vehicle towing capacity.

9465/9475 Hide-A-Goose Installation

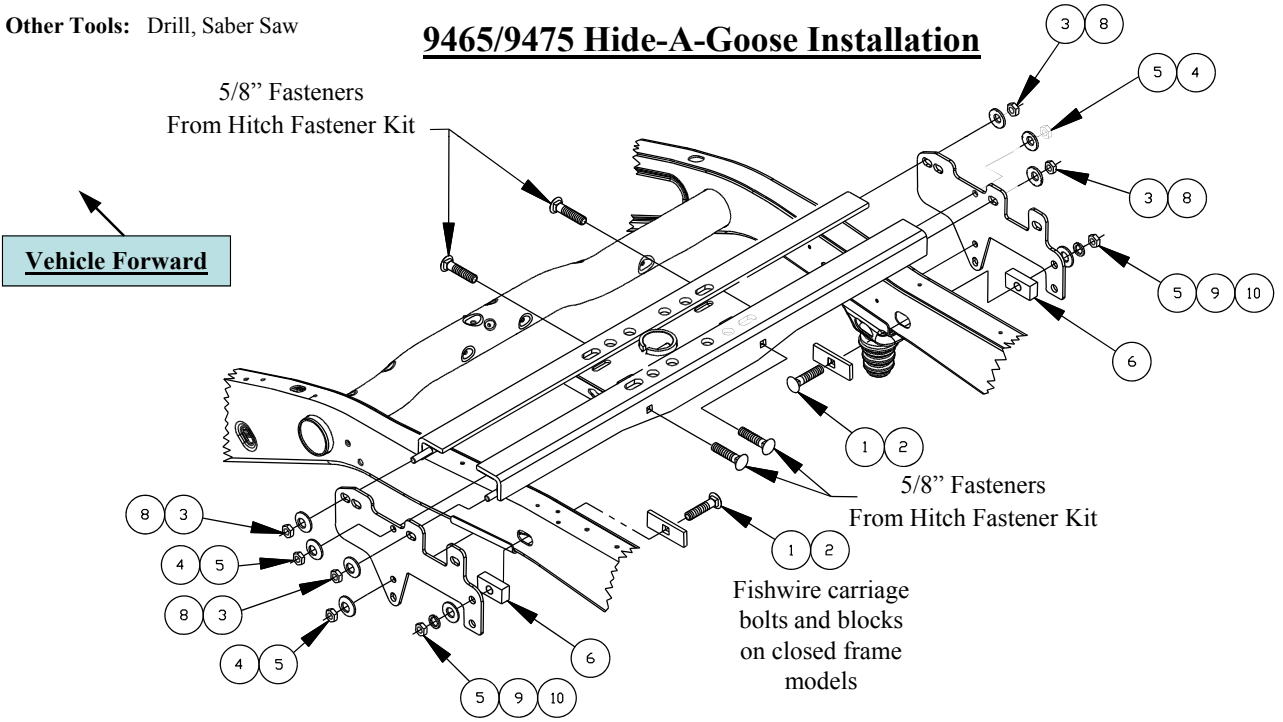
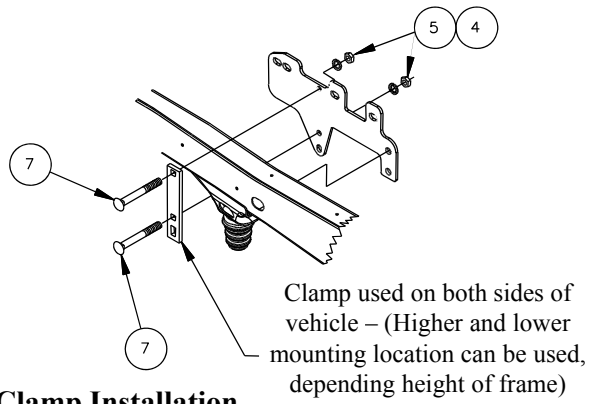

Figure 1



Clamp Installation

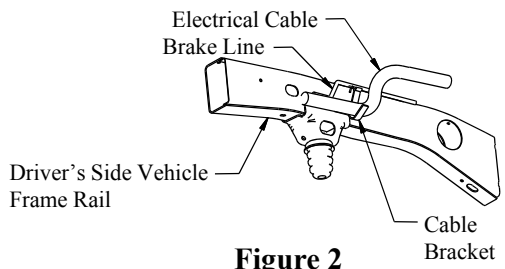

Figure 2

1	Qty. (2)	Carriage Bolt, 1/2-13 x 2.25 GR5	7	Qty. (4)	Carriage Bolt, 1/2 X-13 X 4.50 GR5
2	Qty. (2)	Block, 1/4 X 1.00 X 3.00	8	Qty. (4)	5/8" Conical Toothed Washer
3	Qty. (4)	5/8-11 Hex nut	9	Qty. (2)	Lock Washer, 1/2
4	Qty. (4)	1/2" Conical Toothed Washer	10	Qty. (2)	Flat Washer, 1/2
5	Qty. (6)	Hex Nut, 1/2	11	Qty. (4)	Shims, 5/16 X 2.00 X 1.00
6	Qty. (2)	Block, 5/8 X 1.00 X 2.00	12	Qty. (2)	Fishwire – 1/2

Installation Instructions

Chevrolet/GMC 1500 Short & Long Bed
2500 Light Duty Short Bed

Part Numbers:

4454

NOTES:

- This section of instructions refers to installing the 9465 or 9475 head only.
- Always make sure the ball is fully locked before towing.
- Keep the ball and ball sleeve well lubricated.
- Periodically re-torque all the hitch fasteners.
- Check ball, hitch coupler, safety chains and other connections for proper operation every time you tow.

Warning:

- ❖ The tow vehicle manufacturers recommended towing capacities should **UNDER NO CIRCUMSTANCES** be exceeded.
- ❖ Check for adequate clearance between the gooseneck trailer and the rear of the cab and the rear of the truck box before installing hitch.
- ❖ All trucks have fuel lines, brake lines and electrical wiring located along the vehicle frame where the rail kit installs. Carefully examine the location of fuel lines, brake lines and electrical wires before installation and be certain not to damage these when positioning the hitch components. Be careful when drilling holes, cutting sheet metal and tightening fasteners as to not limit the integrity of these systems.

Hide-A-Goose Only – Drilled hole in bed location (see step 4).
Short Box – 44-3/4 inches
Long Box – 49-1/2 inches

9465/9475 Hide-A-Goose Installation

1. Figure 2 shows a cable bracket which holds a brake line to the inside of the frame rail. Loosen this bracket from the top of the frame and move the brake line down about 1/2" so that it is not interfering with hitch cross members.
2. From underneath the passenger's side of vehicle remove or cut out the section of the heat shield that is located between the frame rails and the bed of the vehicle.
3. Cut the heat shield on the gas tank or bend the top edge down about 1" down to make room for the hitch (see Figure 3).
4. When installing the 9465/9475 Hide-A-Goose hitch, a hole must be drilled in the bed of the truck. Mark and drill a 1/4" hole **44-3/4 inches (short box) / 49-1/2 inches (long box)** from the rear of the bed and centered between the wheel wells. Using a hole saw enlarge pilot hole to final diameter hole size. Refer to the 9465/9475 Hide-A-Goose hitch instruction sheet for hole size.
- 5a. **Placing Cross Members Between Bed And Frame, Method 1: Loosen The Truck Bed:** Remove four truck bed bolts (using 18mm socket) completely from the drivers side frame. The bolts are located on the bottom side of the frame. Loosen, but do not remove, the four bolts holding the bed to the passenger side of the frame. Prop up the driver's side of the truck bed enough to make room for the cross members to fit between the bottom of the truck bed side flange and the top of the frame.
- 5b. **Placing Cross Members Between Bed And Frame, Method 2: Notch the Side Flange:** From the driver's side wheel well, notch the sheet metal flange as shown in Figure 5a for 6' beds and Figure 5b for 8' beds. After notching, the cut steel surfaces should be touched up with paint to prevent rusting.
6. Slide the hitch cross members half way through the notches in the sheet metal flange and place 5/8 carriage bolts from the 9465/9475 fastener kit into the square holes on the vertical leg of the cross members, from underneath the vehicle. Slide the hitch cross members above both vehicle frame rails and align hitch cross members as shown in Figure 6. **Note: if the truck bed has been loosened as in step 5a, the hitch can be loosely preassembled to the cross members, and the hitch and cross members can be slid between the truck bed flange and the vehicle frame (see figure 4). The truck bed will need to be propped up on the driver's side about 3-1/2" to slide the hitch and cross members into position.**
7. Loosely install the 9465/9475 Hide-A-Goose hitch if not done in the previous installation step. Refer to Hide-A-Goose Hitch instruction sheet for installation.
8. Place 1/4 X 1.00 X 3.00 blocks and 1/2 carriage bolts through slots in the driver's side and passenger's side of vehicle frame pointing outwards. Install the 5/8 X 1.00 X 2.00 block onto the carriage bolts. Install the hitch frame brackets by aligning the rearward holes in the brackets with the carriage bolts and install the 1/2 flat washer, lock washers and hex nuts. Loosely install the 5/8-11 hex nuts and conical toothed washers onto the threaded studs on the ends of the hitch cross members (see Figure 7).
9. Install the frame bracket clamp by placing the clamp to the inside of the frame rail, insert the 1/2-13 X 4.50 GR5 carriage bolts through the square holes in the clamp and through the frame bracket with the threaded end pointing outwards. Install the conical toothed washers and hex nuts.
10. After loosely installing the 9465/9475 Hide-A-Goose hitch and mounting kit, carefully align the hitch ball sleeve with the opening cut in the truck bed. Torque all 5/8-11 GR5 fasteners on the brackets to 150 ft.-lb. (203 N-m) and 1/2-13 GR5 fasteners to 75 ft.-lb. (102 N-m). Use the following sequence: a) torque frame brackets to the frame of the vehicle, b) torque cross members to the frame brackets, c) torque Hide-A-Goose hitch to cross members.
11. If vehicle bed was lifted to insert cross members, tighten bolts that attach the bed to the frame.

Installation Instructions

Part Numbers:

Chevrolet/GMC 1500 Short & Long Bed

4454

2500 Light Duty Short Bed

All hardware pictured is from
Hide-A-Goose Hitch fastener kit

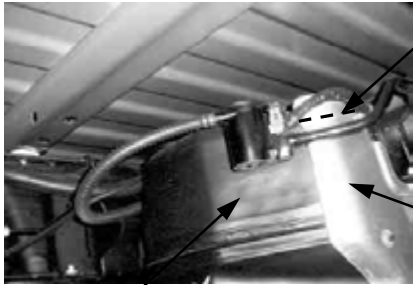

Figure 3
Rear of Gas Tank

Trim or
bend heat
shield here

Forward cross member

Heat
shield

5/8" carriage bolts
5/8" washer
5/8" nut

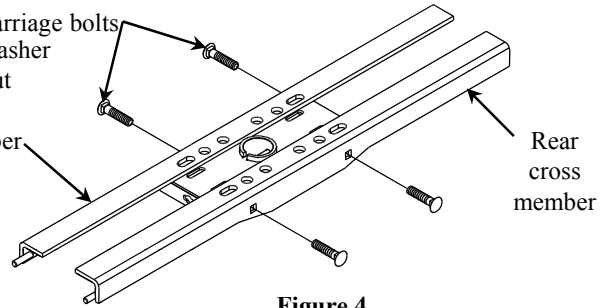

Figure 4

Hitch preassembled to cross members

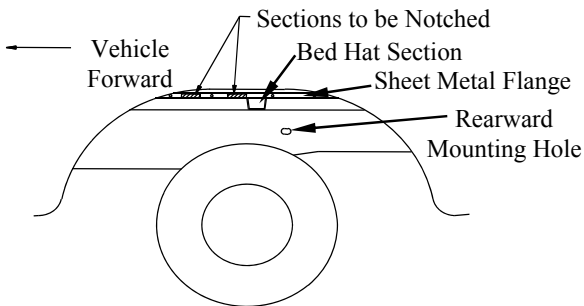

Figure 5a
Short Bed – Hide-A-Goose

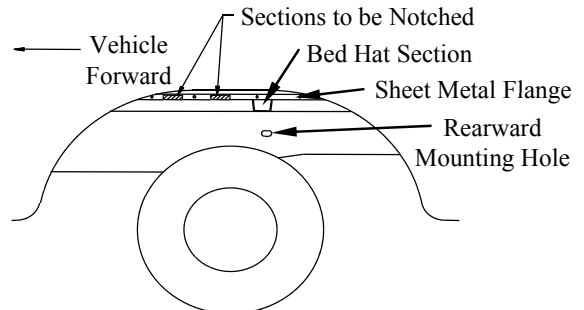

Figure 5b
Long Bed – Hide-A-Goose

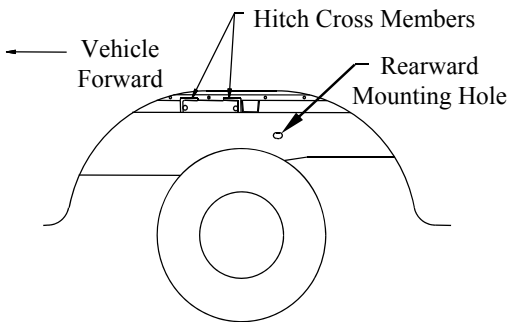

Figure 6a
Short Bed – Hide-A-Goose

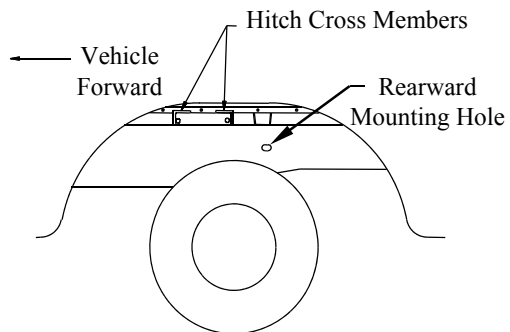

Figure 6b
Long Bed – Hide-A-Goose

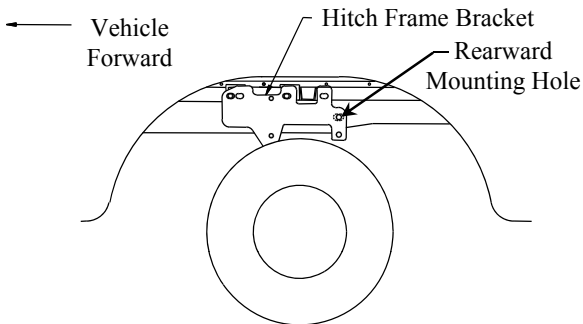

Figure 7a
Short Bed – Hide-A-Goose

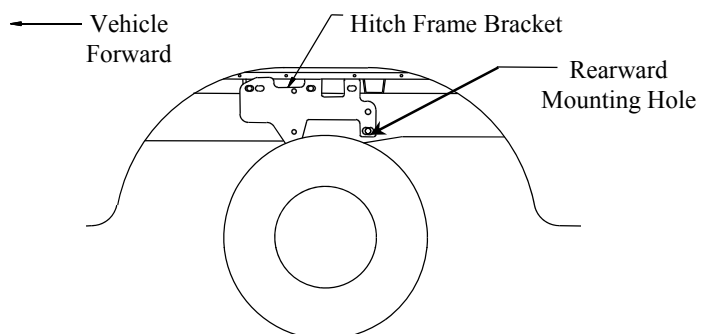

Figure 7b
Long Bed – Hide-A-Goose

Installation Instructions GOOSENECK MOUNTING KIT

Part Numbers:

4454

Chevrolet/GMC 1500 Short & Long Bed
2500 Light Duty Short Bed

Equipment Required:

Fastener Kit: 4454F

Wrenches: 3/4, 15/16, 13mm

Drill Bits: 1/4"

Other Tools: Drill, Saber Saw

WARNING: Under no circumstances do we recommend exceeding the towing vehicle manufacturers recommended vehicle towing capacity.

6300/630044 or 8339 Gooseneck Hitch Installation

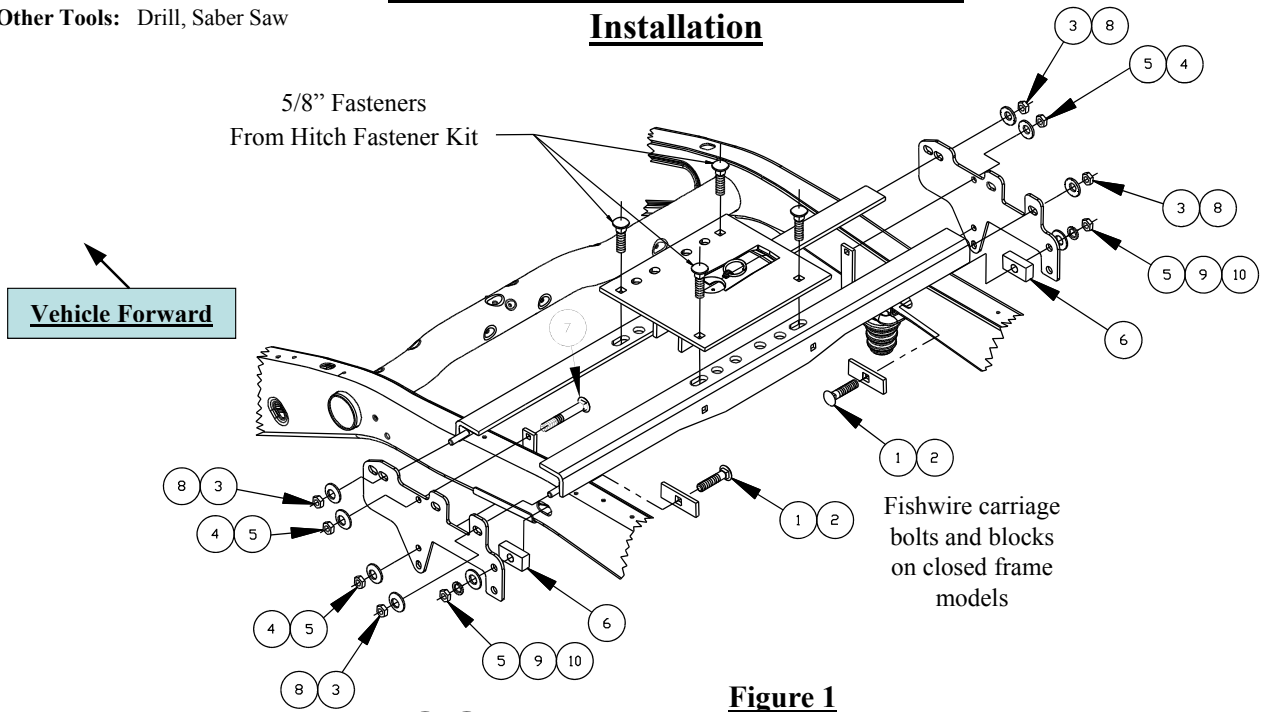
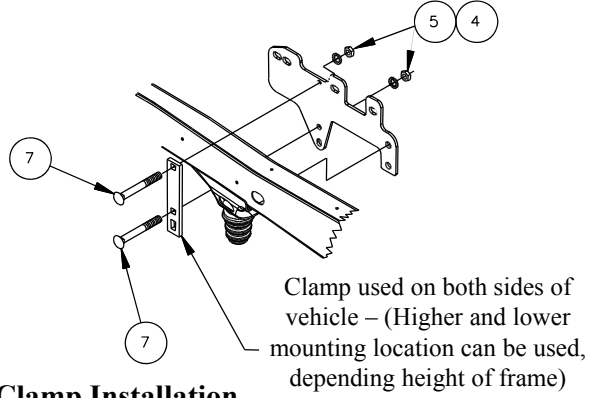

Figure 1



Clamp Installation

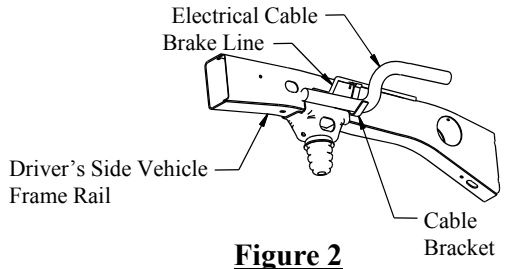

Figure 2

1	Qty. (2)	Carriage Bolt, 1/2-13 x 2.25 GR5	7	Qty. (4)	Carriage Bolt, 1/2 X-13 X 4.50 GR5
2	Qty. (2)	Block, 1/4 X 1.00 X 3.00	8	Qty. (4)	5/8" Conical Toothed Washer
3	Qty. (4)	5/8-11 Hex nut	9	Qty. (2)	Lock Washer, 1/2
4	Qty. (4)	1/2" Conical Toothed Washer	10	Qty. (2)	Flat Washer, 1/2
5	Qty. (6)	Hex Nut, 1/2	11	Qty. (4)	Shims, 5/16 X 2.00 X 1.00
6	Qty. (2)	Block, 5/8 X 1.00 X 2.00	12	Qty. (2)	Fishwire – 1/2

Installation Instructions

Part Numbers:

Chevrolet/GMC 1500 Short & Long Bed
2500 Light Duty Short Bed

4454

NOTES:

- This section of instructions refers to installing the 6300, 630044 or 8339 head only.
- Always make sure the ball is fully locked before towing.
- Keep the ball and ball pocket well lubricated.
- Periodically re-torque all the hitch fasteners.
- Check ball, hitch coupler, safety chains and other connections for proper operation every time you tow.

Warning:

- ❖ The tow vehicle manufacturers recommended towing capacities should **UNDER NO CIRCUMSTANCES** be exceeded.
- ❖ Check for adequate clearance between the gooseneck trailer and the rear of the cab and the rear of the truck box before installing hitch.
- ❖ All trucks have fuel lines, brake lines and electrical wiring located along the vehicle frame where the rail kit installs. Carefully examine the location of fuel lines, brake lines and electrical wires before installation and be certain not to damage these when positioning the hitch components. Be careful when drilling holes, cutting sheet metal and tightening fasteners as to not limit the integrity of these systems.

6300/630044 Remove-A-Ball and 8339 Fold Down Gooseneck Installation

1. Figure 2 shows a cable bracket which holds a brake line to the inside of the frame rail. Loosen this bracket from the top of the frame and move the brake line down about 1/2" so that it is not interfering with hitch cross members.
2. From underneath the passenger's side of vehicle remove or cut out the section of the heat shield that is located between the frame rails and the bed of the vehicle.
- 3a. **Placing Cross Members Between Bed And Frame, Method 1: Loosen The Truck Bed:** Remove four truck bed bolts (using 18mm socket) completely from the drivers side frame. The bolts are located on the bottom side of the frame. Loosen, but do not remove, the four bolts holding the bed to the passenger side of the frame. Prop up the driver's side of the truck bed enough to make room for the cross members to fit between the bottom of the truck bed side flange and the top of the frame.
- 3b. **Placing Cross Members Between Bed And Frame, Method 2: Notch the Side Flange:** From the driver's side wheel well, notch the sheet metal flange as shown in Figure 4a for 6' beds and Figure 4b for 8' beds. After notching, the cut steel surfaces should be touched up with paint to prevent rusting.
4. Slide the hitch cross members above both vehicle frame rails and align hitch cross members as shown in Figure 5.
5. Place 1/4 X 1.00 X 3.00 blocks and 1/2-13 X 2.25 carriage bolts through slots in the driver's side and passenger's side of vehicle frame pointing outwards and install the hitch frame brackets by aligning the rearward holes in the brackets with the fasteners. Loosely install the 5/8-11 hex nuts and conical toothed washers onto the threaded studs on the ends of the hitch cross members (see Figure 6).
6. Install the frame bracket clamp by placing the clamp to the inside of the frame rail, insert the 1/2-13 X 4.50 GR5 carriage bolts through the square holes in the clamp and through the frame bracket with the threaded end pointing outwards. Install the 1/2 conical toothed washers and hex nuts.
7. With the rearward cross member and side brackets in position, torque the 5/8-11 GR5 fasteners that attach the brackets to the rearward cross member to 150 ft.-lb (203 N-m) and the 1/2-13 GR5 fasteners that attach the brackets to the frame to 75 ft.-lb. (102 N-m). The forward cross member should be left loose until step 17. If vehicle bed was lifted to insert cross member, tighten bolts that attach the bed to the frame.



WARNING The fuel tank and/or other vehicle components are located below some of the holes. A wood or metal shield must be placed between the frame and the fuel tank to prevent puncturing the fuel tank when the drill breaks through the bed.

8. For 6300/630044 & 8339 use the center of the outer slots in the rearward hitch cross member as a template to drill 5/8" diameter holes through the truck bed as shown in Figure 3. Not all holes can be drilled from under the vehicle, but will be done later from inside the bed.

6300 / 630044 / 8339 Hole Locations

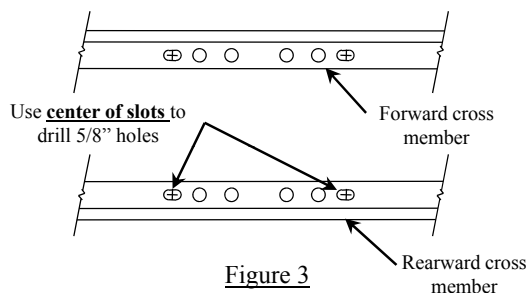

Figure 3

Installation Instructions

Part Numbers:

Chevrolet/GMC 1500 Short & Long Bed 2500 Light Duty Short Bed

4454

- Align the holes on the template (provided with the gooseneck hitch) with the holes previously drilled through the bed. Be sure that the template is properly oriented toward the front of the vehicle. Center punch the holes that will be used to cut the opening in the bed. If the vehicle is equipped with a bed liner, a section of the bed liner must be cut away so that the gooseneck platform can contact the bed corrugations.

Template p/n 5978 for use with 6300/630044 head
Template p/n 114234 for use with 8339 head

Durable and reusable stainless steel templates are also available. A time saver for cutting bed liner and bed.
Template p/n 6467 for use with 6300/630044 head
Template p/n 6425 for use with 8339 head

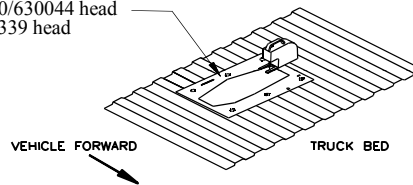

- Drill 1/4" pilot holes (size will depend on width of blade in saber saw). Cut out the truck bed and the bed hat section on short bed models from underneath the bed of the vehicle and file edges as needed.
- Install the hitch into the opening.
- Use the hitch as a guide to drill the 5/8" diameter holes for the forward cross member and the U-Bolt holes.

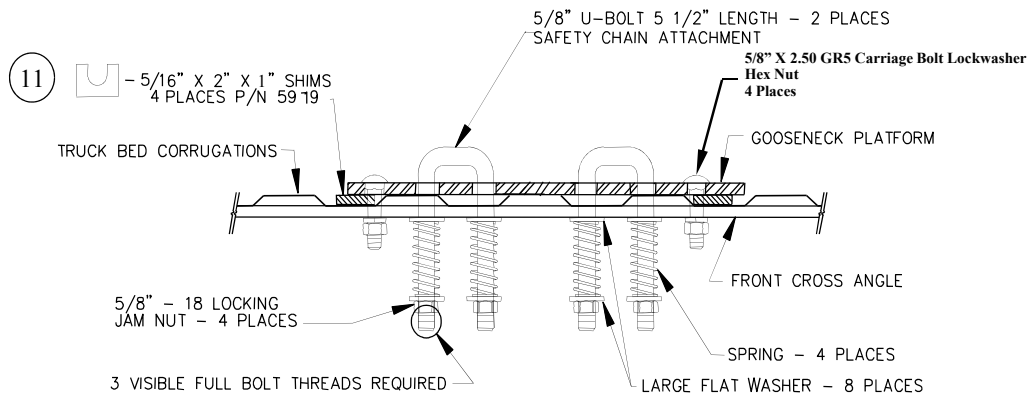

- Before installing the 5/8" carriage bolts through the hitch, the U-block shims (Part Number 5979) must be placed between the hitch and the bed and between the cross members and the bottom of the bed. These shims are necessary to prevent the bed corrugations from collapsing when the bolts are tightened.
- Align the forward cross member with the 5/8 diameter drilled holes.
- Install the 5/8 X 2.50 GR5 carriage bolts through the hitch, shims and cross members. Secure with lock washers and nuts. Torque nuts to 150 ft.-lb. (203 N-m).
- Install the (2) U-Bolts through the hitch and from under the vehicle install the large flat washer over the U-Bolt followed by a spring, another large flat washer and secure with a thin 5/8" jam nut. Repeat for the other legs of the U-Bolts. The 5/8" jam nuts are tightened until (3) threads are visible past the bottom of the jam nut.
- Torque the 5/8 hex nuts, lock washers, and flat washers that attach the brackets to the forward cross member to 150 ft.-lb. (203 N-m).

Installation Instructions

Part Numbers:

Chevrolet/GMC 1500 Short & Long Bed
2500 Light Duty Short Bed

4454

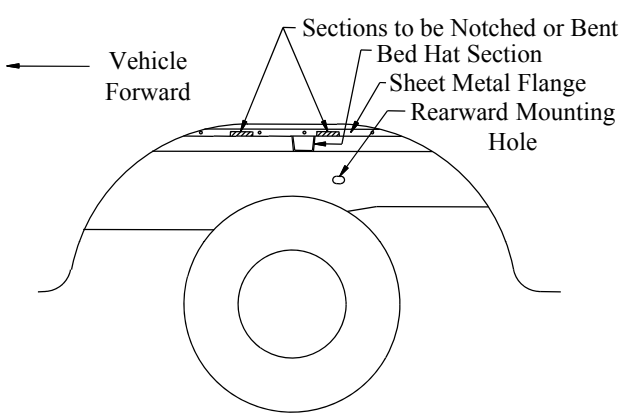

Figure 4a
Short Bed

Remove-A-Ball/Fold Down Gooseneck

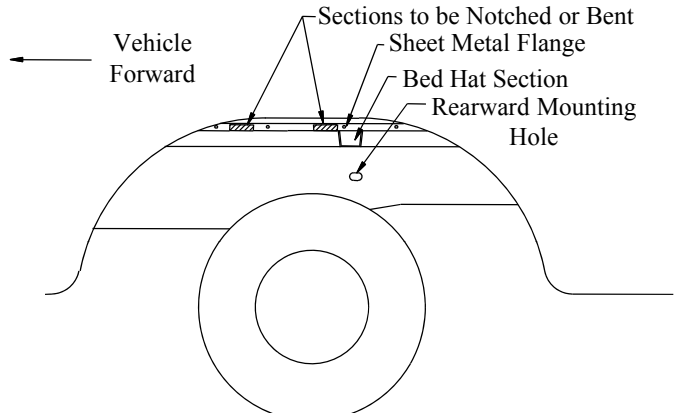

Figure 4b
Long Bed

Remove-A-Ball/Fold Down Gooseneck

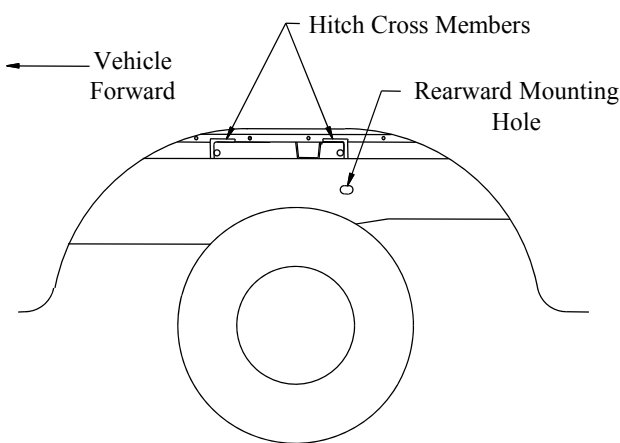

Figure 5a
Short Bed

Remove-A-Ball/Fold Down Gooseneck

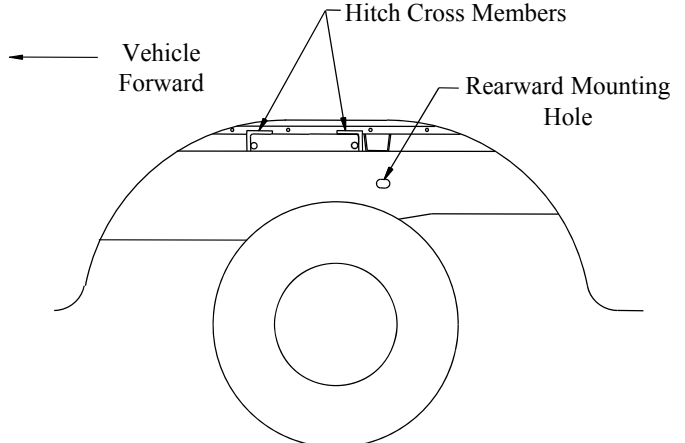

Figure 5b
Long Bed

Remove-A-Ball/Fold Down Gooseneck

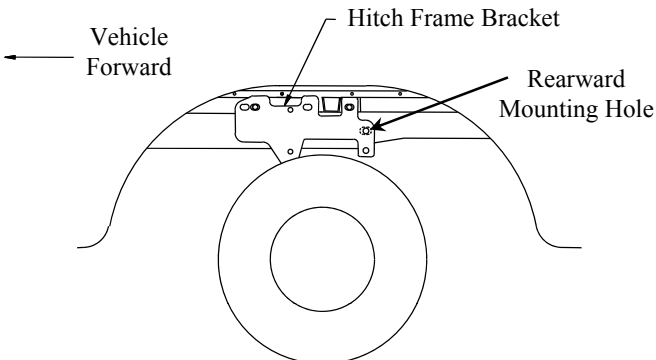

Figure 6a
Short Bed

Remove-A-Ball/Fold Down Gooseneck

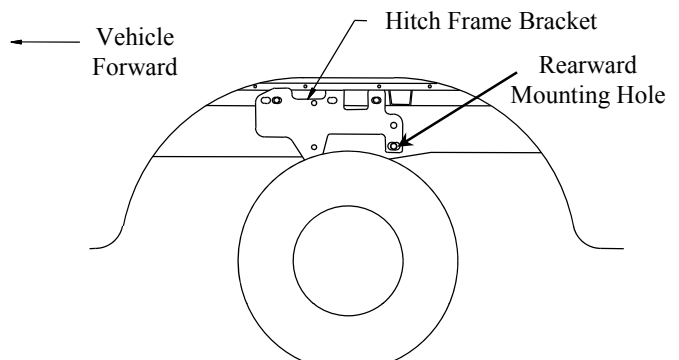

Figure 6b
Long Bed

Remove-A-Ball/Fold Down Gooseneck