

Installation Instructions

GOOSENECK MOUNTING KIT

Chevrolet/GMC 3500 Long Bed
2001 - 2007 "Classic"

Part Numbers:

4445

Equipment Required:

Fastener Kit: 4445F

Wrenches: 3/4, 15/16

Drill Bits: 1/4"

Other Tools: Drill, Reciprocating saw

WARNING: Under no circumstances do we recommend exceeding the towing vehicle manufacturers recommended vehicle towing capacity.

9461/9471 HIDE-A-GOOSE HITCH INSTALLATION

All Fasteners Typical, Both Sides

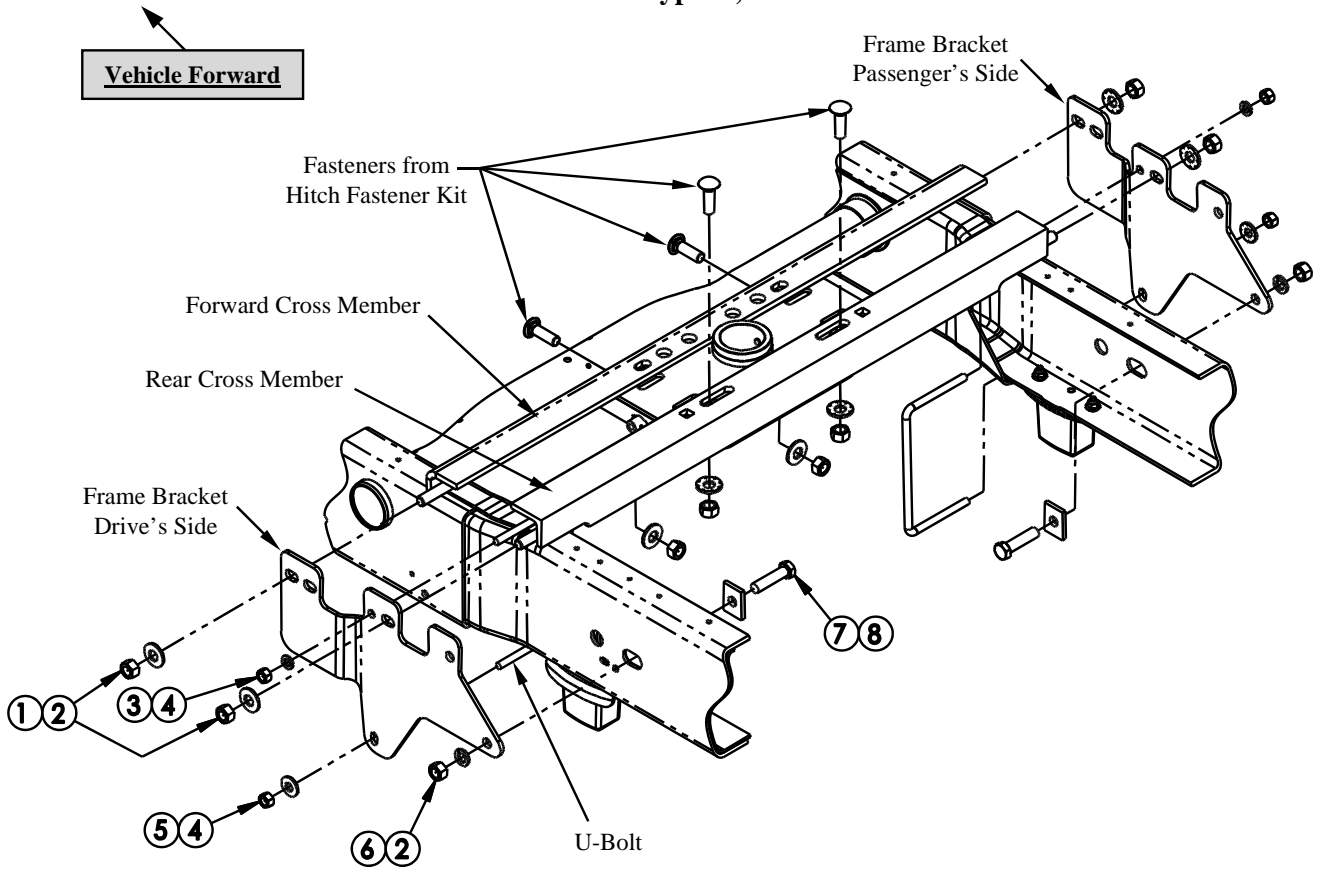

Figure 1

1	Qty. (4)	Conical Toothed Washer, 5/8"	6	Qty. (2)	Lock Washer, 5/8"
2	Qty. (6)	Hex Nut, 5/8"-11	7	Qty. (2)	Hex Bolt, 5/8"-11 x 2"
3	Qty. (4)	Lock Washer, 1/2"	8	Qty. (2)	Spacer, 1/4" x 1-1/2" x 2"
4	Qty. (4)	Hex Nut, 1/2"-13	9	Qty. (4)	Shims, 5/16" x 2" x 1" (not shown in Figure 1)
5	Qty. (2)	Conical Toothed Washer, 1/2"			

Installation Instructions

GOOSENECK MOUNTING KIT

Part Numbers:

4445

Chevrolet/GMC 3500 Long Bed
2001 - 2007 "Classic"

9461/9471 HIDE-A-GOOSE HITCH INSTALLATION

NOTES:

- This rail kit can be used with a 9461 or 9471 head only.
- Always make sure the ball is fully locked before towing.
- Keep the ball and ball sleeve well lubricated.
- Periodically re-torque all the hitch fasteners.
- Check ball, hitch coupler, safety chains and other connections for proper operation every time you tow.

Warning:

- ❖ The tow vehicle manufacturers recommended towing capacities should UNDER NO CIRCUMSTANCES be exceeded.
- ❖ Check for adequate clearance between the gooseneck trailer and the rear of the cab and the rear of the truck box before installing hitch.
- ❖ All trucks have fuel lines, brake lines and electrical wiring located along the vehicle frame where the rail kit installs. Carefully examine the location of fuel lines, brake lines and electrical wires before installation and be certain not to damage these when positioning the hitch components. Be careful when drilling holes, cutting sheet metal and tightening fasteners as to not limit the integrity of these systems.

**Hide-A-Goose Only – Drilled hole in bed location (see Step 5).
Long Box – 52 inches**

Installation Instructions

1. **NOTE: THIS INSTRUCTION IS FOR INSTALLING A GOOSENECK MOUNTING KIT IN CHEVY/GMC 3500 PICKUPS FROM 2001-2007 "CLASSIC MODEL YEARS WITH 8' BEDS. THIS TRUCK HAS TWO BED SUPPORTS OVER THE AXLE.**
2. Lower the spare tire to make installation easier.
3. From underneath the passenger's side of the vehicle remove or cut out the section of the heat shield that is located under the bed and above the exhaust.
4. Cut the heat shield on the gas tank or bend the top edge down about 1" down to make room for the hitch (see Figure 2). On newer models with gasoline engines, temporarily detach the fuel vapor pump from the back of the gas tank.
5. When installing the 9461/9471 Hide-A-Goose hitch, a hole must be drilled in the bed of the truck. Mark and drill a 1/4" hole **52 inches** from the rear of the bed and centered between the wheel wells. Using a hole saw, enlarge the pilot hole to the final diameter hole size. Refer to the 9461/9471 Hide-A-Goose hitch instruction sheet for hole size.

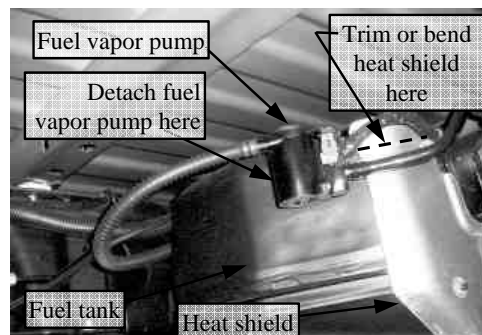

Figure 2
Rear of Gas Tank

Installation Instructions

GOOSENECK MOUNTING KIT

Part Numbers:

4445

Chevrolet/GMC 3500 Long Bed

2001 - 2007 "Classic"

9461/9471 HIDE-A-GOOSE HITCH INSTALLATION

6. From the passenger's side wheel well, cut a 2-1/4" wide notch into the sheet metal flange as shown in Figure 3. Another way to notch the bed flange is to make a single vertical cut, then fold the flange material up enough to allow the for the rails to fit between the frame and the bed. After the rails have been installed, the cut flange may be bent back down to its original position and the cut steel surfaces may be touched up with paint to prevent rusting.

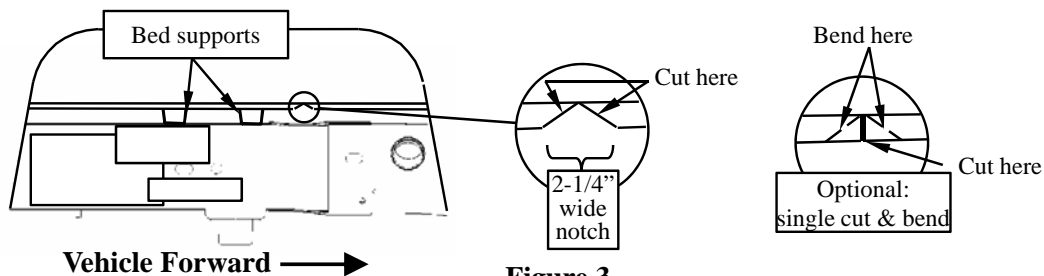

Figure 3

Passenger side

7. Slide the forward cross member through the notch underneath the bed, and over the frame, until it completely spans the passenger's and driver's side frame rails, then slide the cross member forward over the gas tank.
8. Slide the rear cross member through the notch underneath the bed, and over the frame, until it completely spans the passenger's and driver's side frame rails, then slide the cross member back against the bed support.
9. Place two 5/8" Gr8 carriage bolts from the Hide-A-Goose fastener kit into the long slots on the top of the rear cross member, as shown in Figure 1.

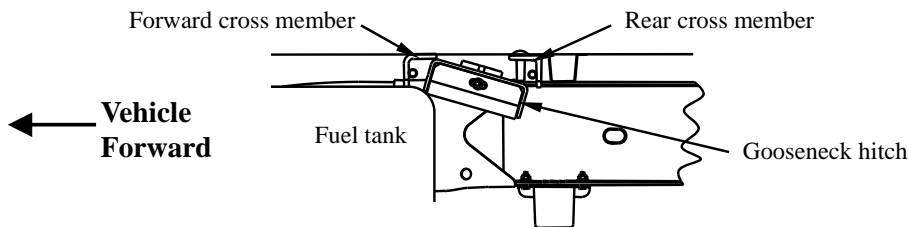

Figure 4

Rotating hitch into position

10. Rotate the front of the hitch over the gas tank (locking pin on the driver's side) and raise the rear of the hitch up, guiding the ends of the 5/8" carriage bolts in the rear rail through the slots in the top of the hitch (see Figure 4). Loosely fasten the back of the hitch to the rear cross member with 5/8" fasteners from the Hide-A-Goose fastener kit.
11. Slide the forward cross member rearward, against the front of the hitch, then place 5/8" Gr8 carriage bolts from the Hide-A-Goose fastener kit through the front of the cross member and the hitch. Loosely fasten the front of the hitch to the front cross member with 5/8" fasteners from the Hide-A-Goose fastener kit.
12. Line up the mounting slots on the frame brackets with the threaded studs on the ends of the rails. See Figure 5 to identify which holes on the frame brackets to use. Loosely attach frame brackets to rails with 5/8" hex nuts and conical toothed washers as shown in Figure 1.

Installation Instructions

GOOSENECK MOUNTING KIT

Part Numbers:

4445

Chevrolet/GMC 3500 Long Bed

2001 - 2007 "Classic"

9461/9471 HIDE-A-GOOSE HITCH INSTALLATION

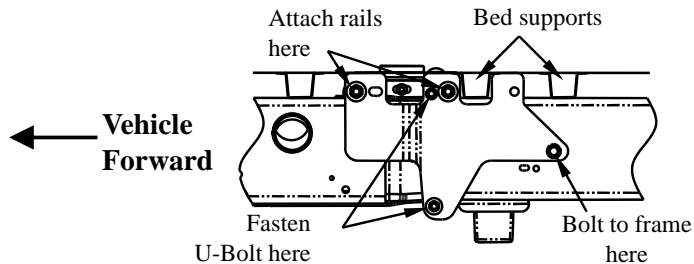

Figure 5

13. Use the U-Bolts to attach the frame brackets to the frame as shown in Figure 1. Loosely fasten the U-Bolts to the frame brackets using a 1/2" nut and lock washer on the top leg of the U-Bolt, and a 1/2" nut and conical washer on the bottom leg of the U-Bolt.
14. Attach the frame bracket to the frame through the slot in the frame using the 5/8" x 2" bolt, 1/4" spacer, lock washer and nut as shown in Figure 1.
15. After carefully aligning the hitch ball sleeve with the opening in the truck bed, tighten the fasteners. Torque all 5/8-11 nuts on the brackets to 150 ft.-lb. (203 N-m) and 1/2-13 GR5 fasteners to 75 ft.-lb. (102 N-m). Torque the 5/8-11 GR8 fasteners attaching the hitch to the cross members to 212 ft.-lb. (287 N-m) Use the following sequence: a) torque frame brackets to the frame of the vehicle, b) torque cross members to the frame brackets c) torque hitch to cross members.
16. Reinstall the fuel vapor pump and the spare tire.

Installation Instructions

GOOSENECK MOUNTING KIT

Chevrolet/GMC 3500 Long Bed
2001 - 2007 "Classic"

Part Numbers:

4445

Equipment Required:

Fastener Kit: 4434F

Wrenches: 3/4, 15/16

Drill Bits: 1/4"

Other Tools: Drill, Reciprocating saw

WARNING: Under no circumstances do we recommend exceeding the towing vehicle manufacturers recommended vehicle towing capacity.

6300/8339/83391/83399 GOOSENECK HITCH INSTALLATION

All Fasteners Typical, Both Sides

5/8" Fasteners
From Hitch
Fastener Kit

Vehicle Forward 

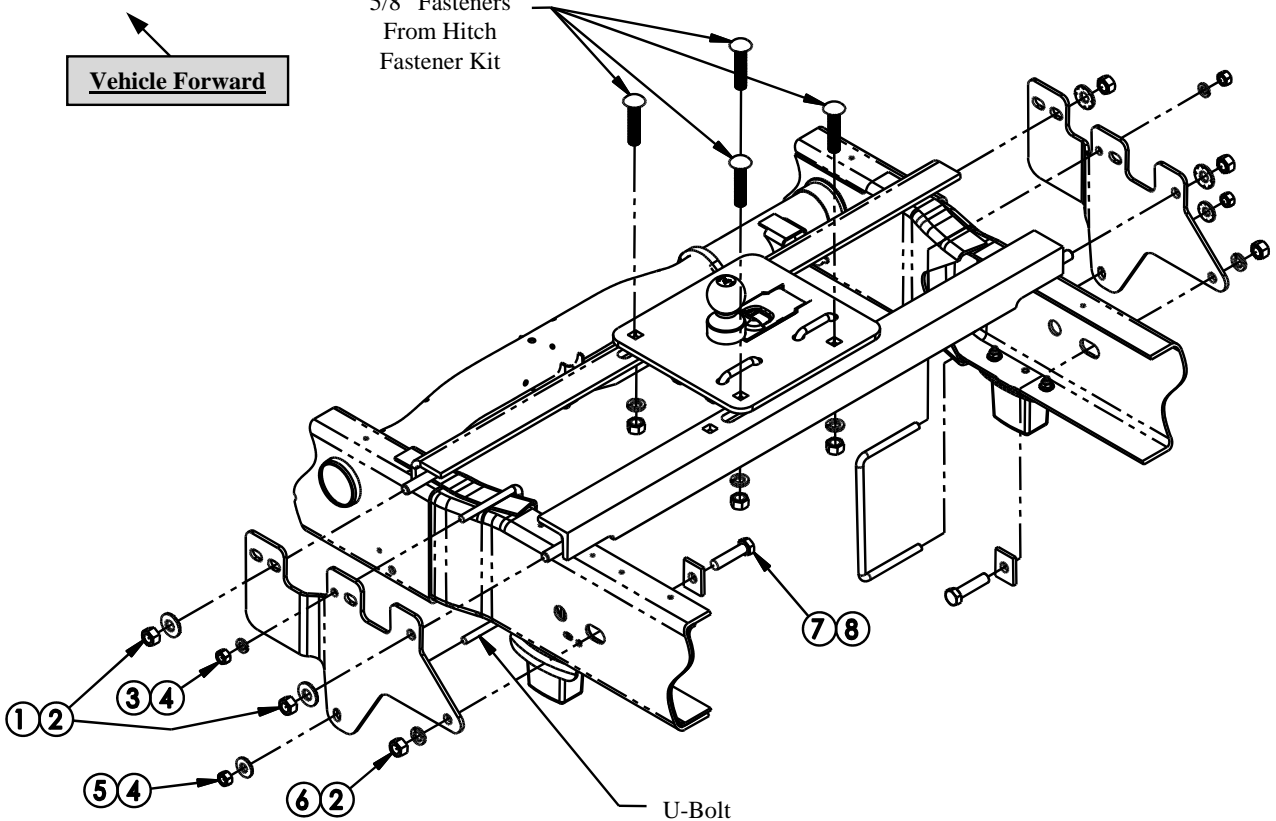

Figure 6

1	Qty. (4)	Conical Toothed Washer, 5/8"	6	Qty. (2)	Lock Washer, 5/8"
2	Qty. (6)	Hex Nut, 5/8"-11	7	Qty. (2)	Hex Bolt, 5/8"-11 x 2"
3	Qty. (4)	Lock Washer, 1/2"	8	Qty. (2)	Spacer, 1/4" x 1-1/2" x 2"
4	Qty. (4)	Hex Nut, 1/2"-13	9	Qty. (4)	Shims, 5/16" x 2" x 1" (not shown in Figure 1)
5	Qty. (2)	Conical Toothed Washer, 1/2"			

Installation Instructions

GOOSENECK MOUNTING KIT

Part Numbers:

4445

Chevrolet/GMC 3500 Long Bed
2001 - 2007 "Classic"

6300/8339/83391/83399 GOOSENECK HITCH INSTALLATION

NOTES:

- This rail kit can be used with a 6300, 8339, 83391 or 83399 head only.
- Always make sure the ball is fully locked before towing.
- Keep the ball and ball pocket well lubricated.
- Periodically re-torque all the hitch fasteners.
- Check ball, hitch coupler, safety chains and other connections for proper operation every time you tow.

Warning:

- ❖ The tow vehicle manufacturers recommended towing capacities should UNDER NO CIRCUMSTANCES be exceeded.
- ❖ Check for adequate clearance between the gooseneck trailer and the rear of the cab and the rear of the truck box before installing hitch.
- ❖ All trucks have fuel lines, brake lines and electrical wiring located along the vehicle frame where the rail kit installs. Carefully examine the location of fuel lines, brake lines and electrical wires before installation and be certain not to damage these when positioning the hitch components. Be careful when drilling holes, cutting sheet metal and tightening fasteners as to not limit the integrity of these systems.

Installation Instructions

1. **NOTE: THIS INSTRUCTION IS FOR INSTALLING A GOOSENECK MOUNTING KIT IN CHEVY/GMC 3500 PICKUPS FROM 2001-2007 "CLASSIC MODEL YEARS WITH 8' BEDS. THIS TRUCK HAS TWO BED SUPPORTS OVER THE AXLE.**
2. Lower the spare tire to make installation easier.
3. From underneath the passenger's side of the vehicle, remove or cut out the section of the heat shield that is located under the bed and above the exhaust.
4. From the passenger's side wheel well, cut a 2-1/4" wide notch into the sheet metal flange between the two bed supports over the rear axle, and another notch in front of the forward bed support as shown in Figure 7. Another way to notch the bed flange is to make a single vertical cut, then fold the flange material up enough to allow the for the rails to fit between the frame and the bed. After the rails have been installed, the cut flange may be bent back down to its original position and the cut steel surfaces may be touched up with paint to prevent rusting.
5. Slide the forward cross member through the forward notch underneath the bed, and over the frame until it completely spans the passenger's and driver's side frame rails.
6. Slide the rear cross member through the notch between the two bed supports, underneath the bed, and over the frame, until it completely spans the passenger's and driver's side frame rails.

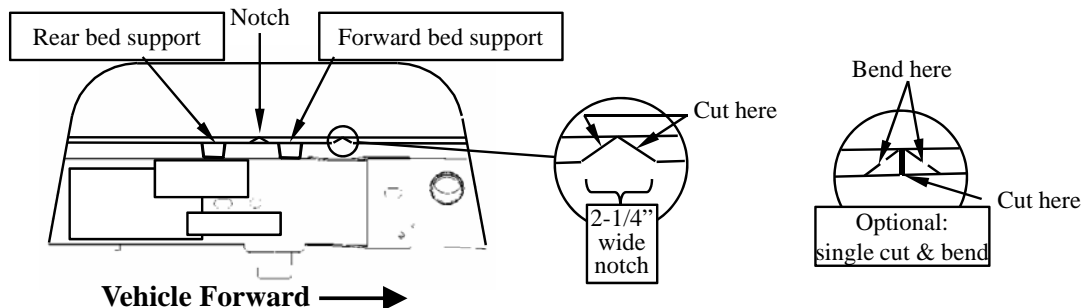

Figure 7
Passenger side

Installation Instructions

GOOSENECK MOUNTING KIT

Part Numbers:

4445

Chevrolet/GMC 3500 Long Bed
2001 - 2007 "Classic"

6300/8339/83391/83399 GOOSENECK HITCH INSTALLATION

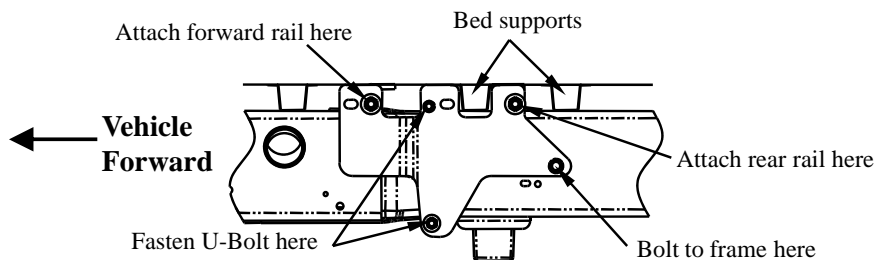

Figure 8

7. Line up the mounting holes on the frame brackets with the threaded studs on the ends of the rails. See Figure 8 to identify which holes on the frame brackets to use. Loosely attach frame brackets to rails with 5/8" hex nuts and conical toothed washers as shown in Figure 6.
8. Use the U-Bolts to loosely attach the frame brackets to the frame as shown in Figure 6.
9. Loosely attach the frame bracket to the frame through the slot in the frame using the 5/8" x 2-1/2" bolt, lock washer and nut as shown in Figure 6.
10. With the rear cross member and side brackets properly aligned, torque 5/8-11 GR5 fasteners tightening the bracket to the frame and the rear cross member to 150 ft.-lb (203 N-m) and 1/2-13 GR5 fasteners on the U-Bolts to 75 ft.-lb. (102 N-m).
- 11a. **For 6300 & 8339** use the **outer** edges of the long slots in the rearward cross member as a template to drill 5/8" diameter holes through the truck bed as shown in Figure 9a. Due to the fuel tank, not all holes can be drilled from under the vehicle, but should be done later from inside the bed.
- 11b. **For 83391 & 83399** use the **inner** edges of the long slots in the rearward cross member as a template to drill 5/8" diameter holes through the truck bed as shown in Figure 9b. Due to the fuel tank, not all holes can be drilled from under the vehicle, but should be done later from inside the bed.

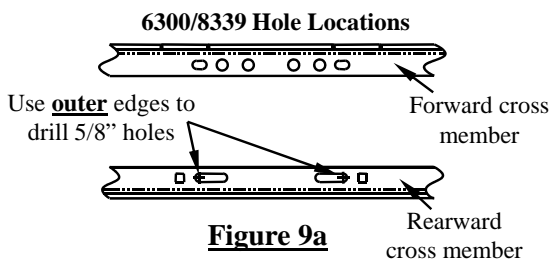

Figure 9a

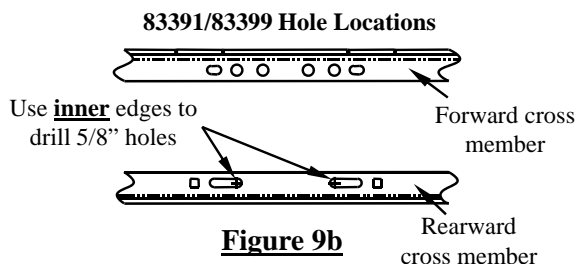

Figure 9b

Template p/n 5978 for use with 6300 head
Template p/n 114234 for use with 8339 head
Template p/n 114523 for use with 83391/83399 heads
Durable and reusable stainless steel templates are also available. A time saver for cutting bed liner and bed.
Template p/n 6467 for use with 6300 head
Template p/n 6425 for use with 8339 head
Template p/n 58384 for use with 83391/83399 heads

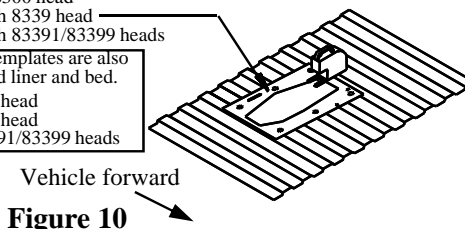

Figure 10

12. Align the holes on the template (provided with the gooseneck hitch) with the holes for the rear cross member previously drilled through the bed. Be sure that the template is properly oriented toward the front of the vehicle. See Figure 10. Center punch the holes that will be used to cut the opening in the bed. If the vehicle is equipped with a bed liner, a section of the bed liner must be cut away so that the gooseneck platform can contact the bed corrugations.

Installation Instructions

GOOSENECK MOUNTING KIT

Part Numbers:

4445

Chevrolet/GMC 3500 Long Bed
2001 - 2007 "Classic"

6300/8339/83391/83399 GOOSENECK HITCH INSTALLATION



WARNING The fuel tank and/or other vehicle components are located below some of the holes. A wood or metal shield must be placed between the frame and the fuel tank to prevent puncturing the fuel tank when the drill breaks through the bed.

13. Drill 1/4" pilot holes (size will depend on width of blade in saber saw).
14. Cut out the truck bed and the bed hat section and file edges as needed.
15. Install the hitch into the opening.

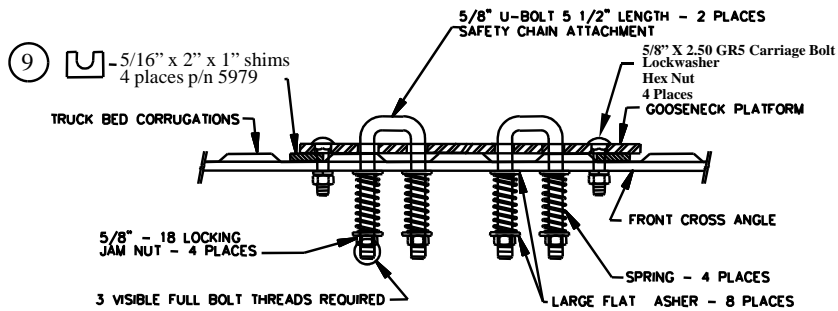

Figure 11

16. Use the hitch as a guide to drill 5/8" the forward 5/8" diameter mounting holes. Also, drill 5/8" diameter U-Bolt holes if installing a 6300 or 8339 gooseneck hitch.
17. Before installing the 5/8" carriage bolts through the hitch, the U-block shims must be placed between the hitch and the bed and between the cross members and the bottom of the bed. These shims are necessary to prevent the bed corrugations from collapsing when the bolts are tightened.
18. Install the 5/8 X 2.50 GR5 carriage bolts from the hitch fastener kit through the hitch, shims and cross members. Secure with lock washers and nuts from the hitch fastener kit and torque nuts to 150 ft.-lb. (203 N-m). Torque 5/8-11 GR5 nuts attaching the forward cross member to the brackets 150 ft.-lb (203 N-m).
19. **For 6300 and 8339 Installations:** Install the (2) safety chain U-Bolts through the hitch and from under the vehicle install the large flat washer over the U-Bolt followed by a spring, another large flat washer and secure with a thin 5/8" jam nut (see Figure 11). Repeat for the other legs of the U-Bolts. The 5/8" jam nuts are tightened until (3) threads are visible past the bottom of the jam nut.
20. Reinstall the spare tire.