



Installation Instructions

GOOSENECK MOUNTING KIT

Chevrolet/GMC 2500/3500 Heavy Duty
Short & Long Bed

Part Numbers:
4434

Equipment Required:

- Fastener Kit:** 4434F
- Wrenches:** 3/4, 15/16, 10mm, 18mm
- Drill Bits:** 1/4"
- Other Tools:** Drill, Reciprocating saw

WARNING: Under no circumstances do we recommend exceeding the towing vehicle manufacturers recommended vehicle towing capacity.

9461/9471 HIDE-A-GOOSE HITCH

INSTALLATION

All Fasteners Typical, Both Sides

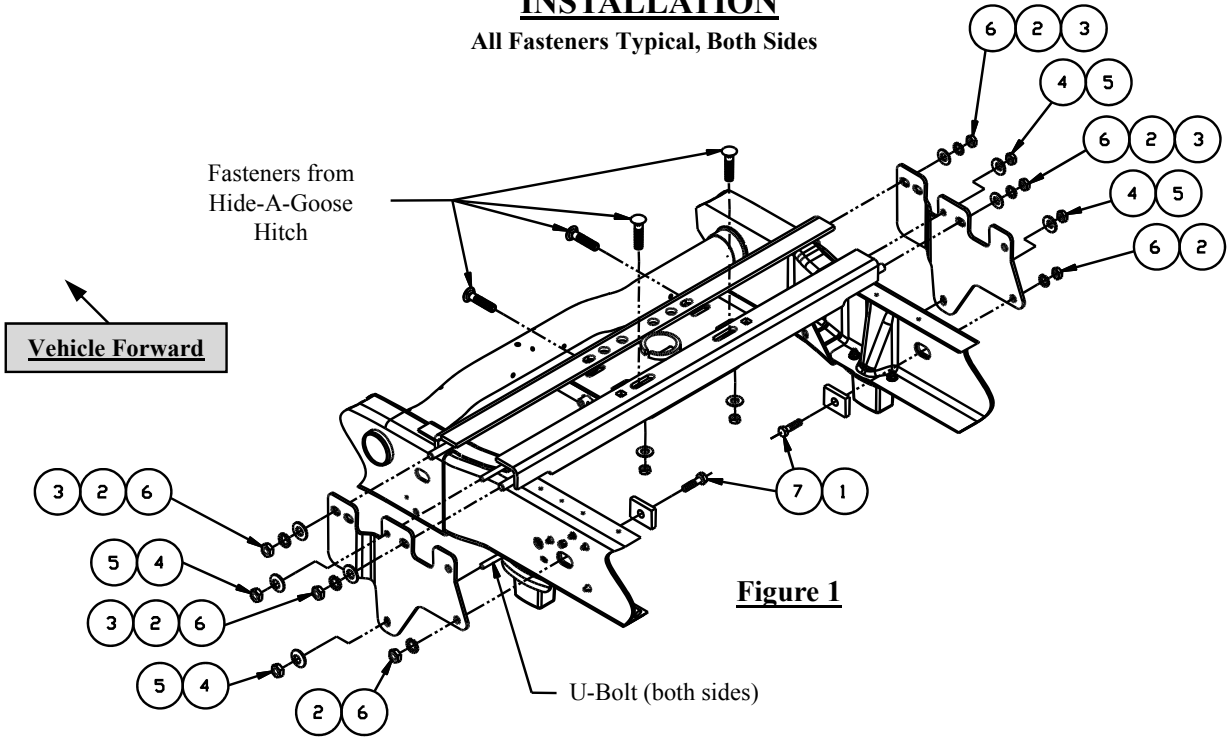

Figure 1

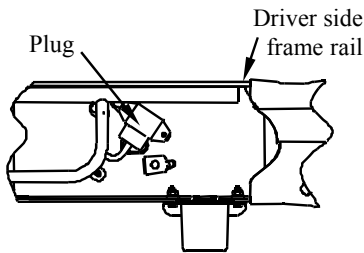

Figure 2a

Inside driver side frame rail

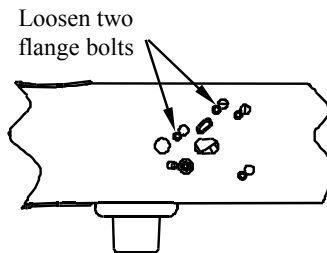

Figure 2b

Outside driver side frame rail

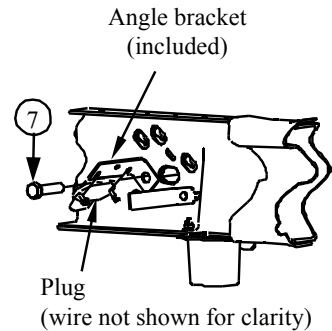

Figure 2c

1	Qty. (2)	Spacer, 3/8 x 1-1/2" x 2"	5	Qty. (4)	Conical Washer, 1/2"
2	Qty. (6)	Lock Washer, 5/8"	6	Qty. (6)	Hex Nut, 5/8"-11
3	Qty. (4)	Flat Washer, 5/8"	7	Qty. (2)	Hex Bolt, 5/8"-11 x 2-1/2" GR5
4	Qty. (4)	Hex Nut, 1/2"-13	8	Qty. (4)	Shims, 5/16" x 2" x 1" (not shown in Figure 1)

Installation Instructions

GOOSENECK MOUNTING KIT

Part Numbers:

4434

Chevrolet/GMC 2500/3500 Heavy Duty
Short & Long Bed

9461/9471 HIDE-A-GOOSE HITCH INSTALLATION

NOTES:

- This rail kit can be used with a 9461 or 9471 head only.
- Always make sure the ball is fully locked before towing.
- Keep the ball and ball sleeve well lubricated.
- Periodically re-torque all the hitch fasteners.
- Check ball, hitch coupler, safety chains and other connections for proper operation every time you tow.

Warning:

- ❖ The tow vehicle manufacturers recommended towing capacities should UNDER NO CIRCUMSTANCES be exceeded.
- ❖ Check for adequate clearance between the gooseneck trailer and the rear of the cab and the rear of the truck box before installing hitch.
- ❖ All trucks have fuel lines, brake lines and electrical wiring located along the vehicle frame where the rail kit installs. Carefully examine the location of fuel lines, brake lines and electrical wires before installation and be certain not to damage these when positioning the hitch components. Be careful when drilling holes, cutting sheet metal and tightening fasteners as to not limit the integrity of these systems.

Hide-A-Goose Only – Drilled hole in bed location (see step 5).

Short Box – 44-1/2 inches

Long Box – 49-3/8 inches

Installation Instructions

1. Lower the spare tire and the exhaust to make installation easier.
2. **2007 New Body Style and later trucks with OE Trailer Brake Control:** Relocate the electrical plug that is located on the inside of the driver's side frame over the rear wheel (Figure 2a). The plug may be removed from the frame by loosening the two bolts on the outside of the frame and pushing the bolt heads through the key hole slots, as shown in Figure 2b. Attach the plug to the angle bracket supplied with the mounting kit. The bracket will be attached to the inside of the frame with a 5/8" bolt at a later step.
3. From underneath the passenger's side of the vehicle, remove or cut out the section of the heat shield that is located under the bed, above the exhaust, and between the two bed supports, over the axle.
4. Cut the heat shield on the gas tank or bend the top edge about 1" down to make room for the hitch. See Figure 3. On newer models with gasoline engines, temporarily detach the fuel vapor pump from the back of the gas tank.
5. When installing the 9461/9471 Hide-A-Goose hitch, a hole must be drilled in the bed of the truck. Mark and drill a 1/4" hole **44-1/2 inches (6' bed) / 49-3/8 inches (8' bed all 2500 pickups and 2007 "New Body Style" and later 3500 pickups)** from the rear of the bed and centered between the wheel wells. Using a hole saw, enlarge the pilot hole to the final diameter hole size. Refer to the 9461/9471 Hide-A-Goose hitch instruction sheet for hole size.

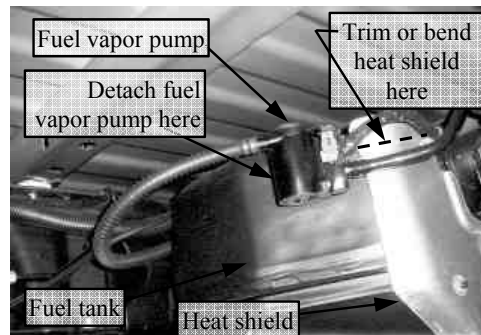

Figure 3

Rear of Gas Tank

Installation Instructions

GOOSENECK MOUNTING KIT

Part Numbers:

4434

Chevrolet/GMC 2500/3500 Heavy Duty
Short & Long Bed

9461/9471 HIDE-A-GOOSE HITCH INSTALLATION

- 6a. **Placing Cross Members Between Bed And Frame, Method 1: Loosening The Truck Bed.** Remove four truck bed bolts (using 18mm socket) completely from the driver's side frame. The bolts are located on the bottom side of the frame. Loosen, but do not remove, the four bolts holding the bed to the passenger's side of the frame. Prop up the driver's side of the truck bed enough to make room for the cross members to fit between the bottom of the truck bed side flange and the top of the frame.
- 6b. **Placing Cross Members Between Bed And Frame, Method 2: Notching the Side Flange.** From the passenger's side wheel well, notch the sheet metal flange as shown in Figure 4a for 6' beds and Figure 4b for 8' beds. After notching, the cut steel surfaces should be touched up with paint to prevent rusting.

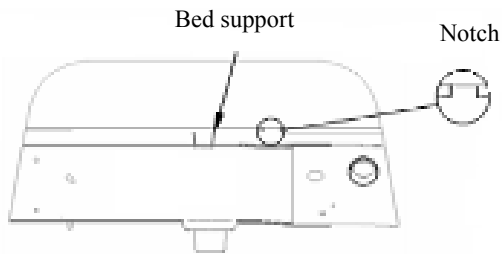

Figure 4a
6' beds

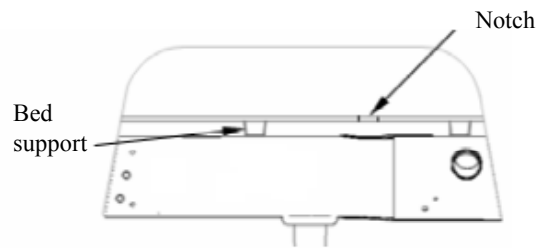

Figure 4b
8' beds

7. Slide the hitch cross members half way through the notches in the sheet metal flange and place 5/8 carriage bolts from the Hide-A-Goose hitch fastener kit into the long slots on the rearward cross member from underneath the vehicle. Slide the hitch cross members above both vehicle frame rails and align hitch cross members as shown in Figure 6. **Note: if the truck bed has been loosened as in step 6a, the hitch can be loosely preassembled to the cross members, and the hitch and cross members can be slid between the truck bed flange and the vehicle frame (see figure 5). The truck bed will need to be propped up on the driver's side about 3-1/2" to slide the hitch and cross members into position.**

All hardware pictured is from
Hide-A-Goose Hitch fastener kit

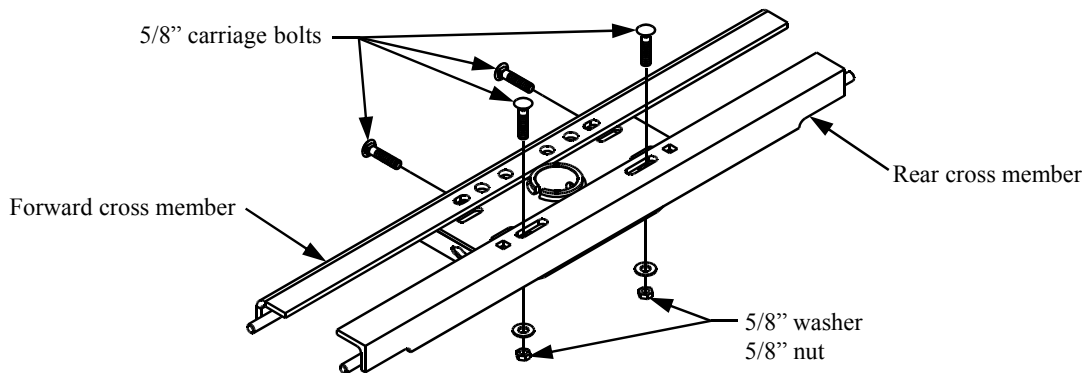

Figure 5

Hitch preassembled to cross members

8. Line up the mounting slots on the frame brackets with the threaded studs on the ends of the cross members. See Figure 6 to identify which holes on the frame brackets to use. Loosely attach frame brackets to cross members with 5/8" hex nuts, lock washers and flat washers as shown in Figure 1.

Installation Instructions

GOOSENECK MOUNTING KIT

Part Numbers:

4434

Chevrolet/GMC 2500/3500 Heavy Duty
Short & Long Bed

9461/9471 HIDE-A-GOOSE HITCH INSTALLATION

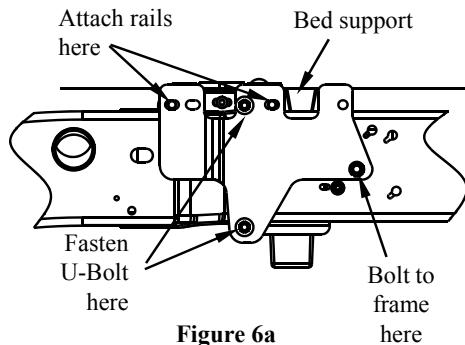

Figure 6a
6' beds

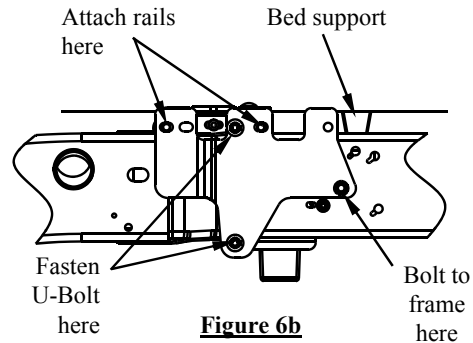

Figure 6b
8' beds

2001 & up 2500 pickups
2007 "New Body Style" 3500 pickups

9. Use the U-Bolts to attach the frame brackets to the frame as shown in Figure 1.
10. Loosely fasten the U-Bolts to the frame brackets using the 1/2" nuts and conical washers.
11. Attach the frame bracket to the frame through the slot in the frame using the 5/8" x 2-1/2" bolt, lock washer and nut as shown in Figure 1.
Note: On 2007 "New Body Style" and later pickups with OE trailer brake control, refer to Step 2 to relocate the plug with the angle bracket. Use the 5/8" x 2-1/2" bolt to attach the angle bracket to the inside of the frame.
12. Loosely install the Hide-A-Goose hitch to the rearward cross member. Place 5/8" carriage bolts through the square holes on the vertical leg of the forward cross member and attach the hitch to the horizontal mounting locations (see figure 1 and refer to the Hide-A-Goose hitch instruction sheet).
13. If you loosened the bed in Step 6a, reinstall the bed bolts and tighten all of them.
14. Torque all 5/8-11 GR5 fasteners on the brackets to 150 ft.-lb. (203 N-m) and 1/2-13 GR5 fasteners to 75 ft.-lb. (102 N-m). Torque the 5/8-11 GR8 fasteners attaching the hitch to the cross members to 212 ft.-lb. (287 N-m) Use the following sequence: a) torque frame brackets to the frame of the vehicle, b) torque cross members to the frame brackets c) torque hitch to cross members.
15. Reinstall the fuel vapor pump, exhaust, and the spare tire.

Installation Instructions

GOOSENECK MOUNTING KIT

Chevrolet/GMC 2500/3500 Heavy Duty
Short & Long Bed

Part Numbers:

4434

Equipment Required:

Fastener Kit: 4434F

Wrenches: 3/4, 15/16, 10mm, 18mm

Drill Bits: 1/4"

Other Tools: Drill, Reciprocating saw

WARNING: Under no circumstances do we recommend exceeding the towing vehicle manufacturers recommended vehicle towing capacity.

6300/8339/83391/83399 GOOSENECK HITCH INSTALLATION

All Fasteners Typical, Both Sides

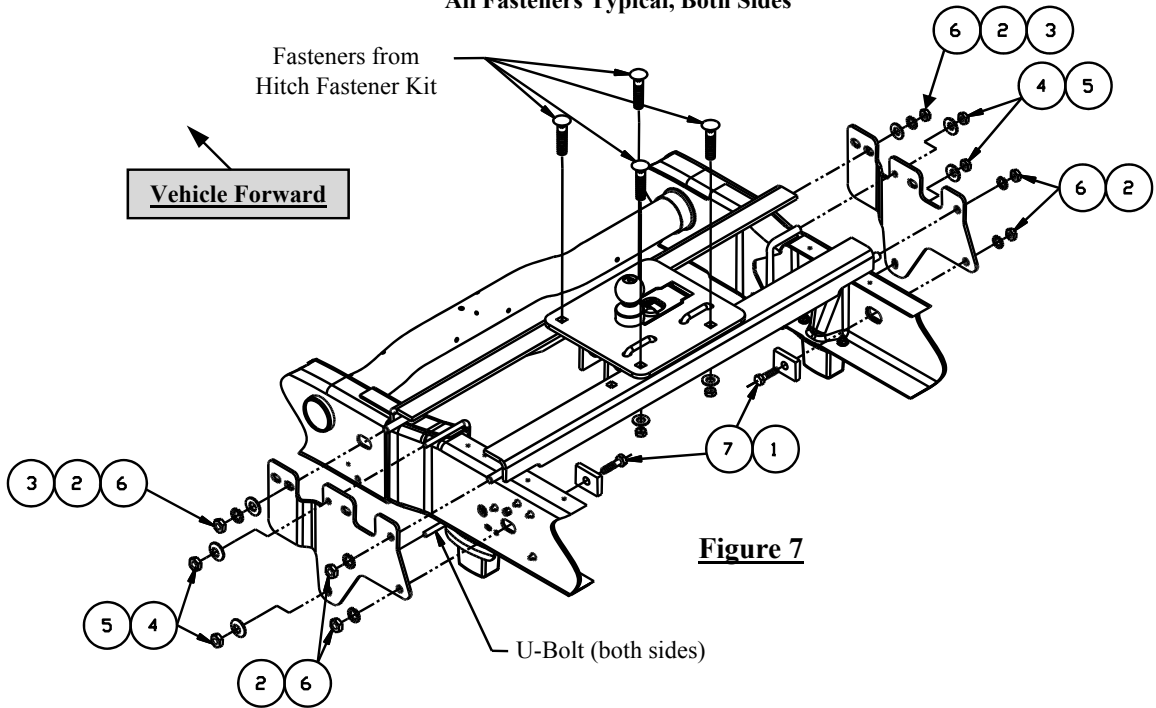

Figure 7

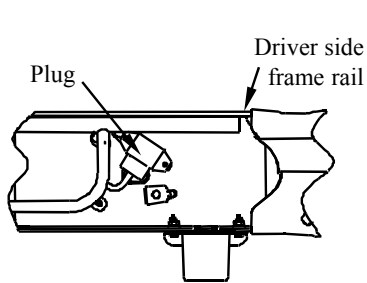

Figure 8a

Inside driver side frame rail

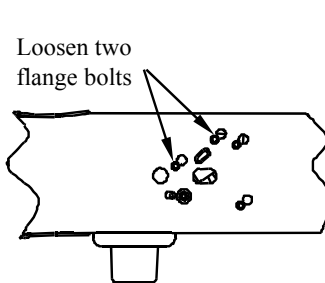

Figure 8b

Outside driver side frame rail

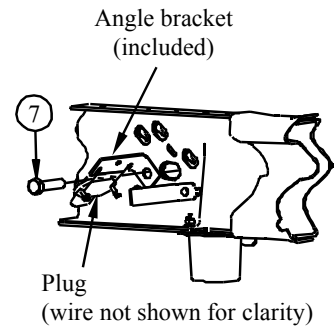

Figure 8c

1	Qty. (2)	Spacer, 3/8 x 1-1/2" x 2"	5	Qty. (4)	Conical Washer, 1/2"
2	Qty. (6)	Lock Washer, 5/8"	6	Qty. (6)	Hex Nut, 5/8"-11
3	Qty. (4)	Flat Washer, 5/8"	7	Qty. (2)	Hex Bolt, 5/8"-11 x 2-1/2" GR5
4	Qty. (4)	Hex Nut, 1/2"-13	8	Qty. (4)	Shims, 5/16" x 2" x 1" (not shown in Figure 1)

Installation Instructions

Part Numbers:

GOOSENECK MOUNTING KIT

4434

Chevrolet/GMC 2500/3500 Heavy Duty

Short & Long Bed

6300/8339/83391/83399 GOOSENECK HITCH INSTALLATION

NOTES:

- This rail kit can be used with a 6300, 8339, 83391 or 83399 head only.
- Always make sure the ball is fully locked before towing.
- Keep the ball and ball pocket well lubricated.
- Periodically re-torque all the hitch fasteners.
- Check ball, hitch coupler, safety chains and other connections for proper operation every time you tow.

Warning:

- ❖ The tow vehicle manufacturers recommended towing capacities should UNDER NO CIRCUMSTANCES be exceeded.
- ❖ Check for adequate clearance between the gooseneck trailer and the rear of the cab and the rear of the truck box before installing hitch.
- ❖ All trucks have fuel lines, brake lines and electrical wiring located along the vehicle frame where the rail kit installs. Carefully examine the location of fuel lines, brake lines and electrical wires before installation and be certain not to damage these when positioning the hitch components. Be careful when drilling holes, cutting sheet metal and tightening fasteners as to not limit the integrity of these systems.

Installation Instructions

1. Lower the spare tire and the exhaust to make installation easier.
2. **2007 New Body Style and later trucks with OE Trailer Brake Control:** Relocate the electrical plug that is located on the inside of the driver's side frame over the rear wheel (Figure 8a). The plug may be removed from the frame by loosening the two bolts on the outside of the frame and pushing the bolt heads through the key hole slots, as shown in Figure 8b. Attach the plug to the angle bracket supplied with the mounting kit. The bracket will be attached to the inside of the frame with a 5/8" bolt at a later step.
3. From underneath the passenger's side of the vehicle remove or cut out the section of the heat shield that is located under the bed, above the exhaust, and between the two bed supports over the axle.
- 4a. **Placing Cross Members Between Bed And Frame, Method 1: Loosen The Truck Bed.** Remove four truck bed bolts (using 18mm socket) completely from the driver's side frame. The bolts are located on the bottom side of the frame. Loosen, but do not remove, the four bolts holding the bed to the passenger side of the frame. Prop up the driver's side of the truck bed enough to make room for the cross members to fit between the bottom of the truck bed side flange and the top of the frame.
- 4b. **Placing Cross Members Between Bed And Frame, Method 2: Notch the Side Flange.** From the passenger's side wheel well, notch the sheet metal flange as shown in Figure 9a for 6' beds and Figure 9b for 8' beds. After notching, the cut steel surfaces should be touched up with paint to prevent rusting.
5. Slide the hitch cross members through the notch(es) in the sheet metal flange. Figure 7 shows the forward and rear rail and the direction to orient each rail.
6. Line up the mounting holes on the frame brackets with the threaded studs on the ends of the rails. See Figure 10 to identify which holes on the frame brackets to use. Loosely attach frame brackets to rails with 5/8" hex nuts, lock washers, and flat washers as shown in Figure 7.

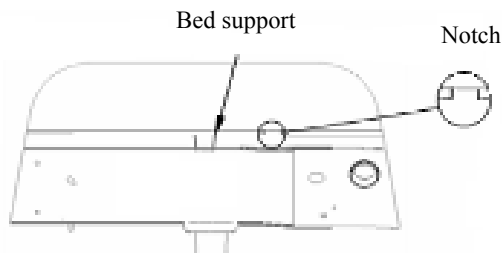

Figure 9a
6' beds

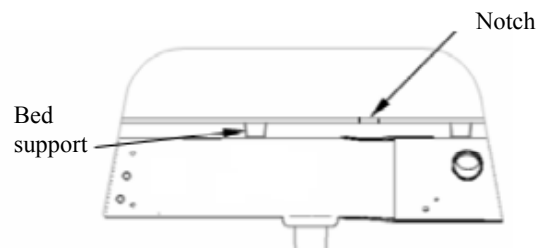

Figure 9b
8' beds

Installation Instructions

GOOSENECK MOUNTING KIT

Part Numbers:

4434

Chevrolet/GMC 2500/3500 Heavy Duty

Short & Long Bed

6300/8339/83391/83399 GOOSENECK HITCH INSTALLATION

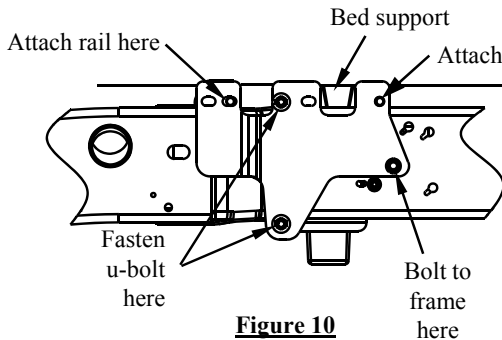

Figure 10
6' beds

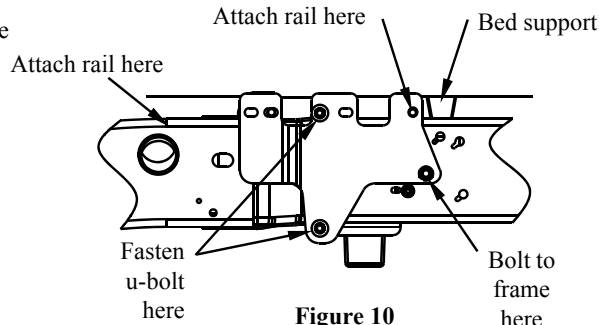

Figure 10
8' beds

7. Use the U-Bolts to attach the frame brackets to the frame as shown in Figure 7.
8. Attach the frame bracket to the frame through the slot in the frame using the 5/8" x 2-1/2" bolt, lock washer and nut as shown in Figure 7.

Note: On 2007 "New Body Style" pickups with OE trailer brake control, refer to Step 2 to relocate the plug with the angle bracket. Use the 5/8" x 2-1/2" bolt to attach the angle bracket to the inside of the frame.

9. With the cross members and side brackets properly aligned, torque all 5/8-11 GR5 fasteners on the bracket to 150 ft.-lb (203 N-m). Torque 1/2-13 GR5 U-Bolt fasteners to 75 ft.-lb. (102 N-m). Also, reinstall and tighten all bed fasteners if they were loosened or removed during rail installation.

10a. For 6300 & 8339 use the **outer** edges of the long slots in the rearward cross member as a template to drill 5/8" diameter holes through the truck bed as shown in Figure 11a. Due to the fuel tank, not all holes can be drilled from under the vehicle, but should be done later from inside the bed.

10b. For 83391 & 8339 use the **inner** edges of the long slots in the rearward cross member as a template to drill 5/8" diameter holes through the truck bed as shown in Figure 11b. Due to the fuel tank, not all holes can be drilled from under the vehicle, but should be done later from inside the bed.

6300/8339 Hole Locations

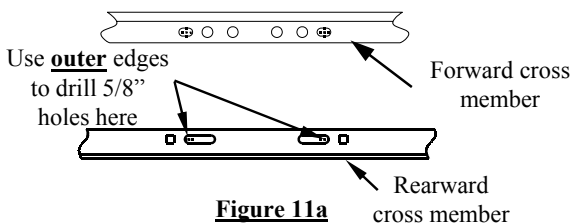

Figure 11a

83399/83391 Hole Locations

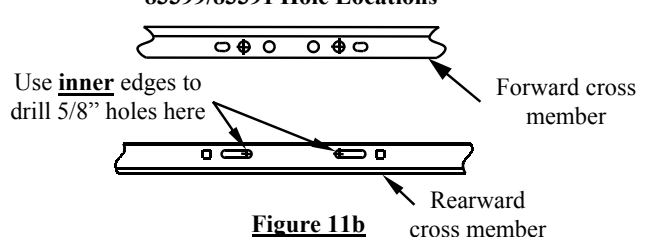

Figure 11b

11. Align the holes on the template (provided with the gooseneck hitch) with the holes previously drilled through the bed. Be sure that the template is properly oriented toward the front of the vehicle (see Figure 12). Center punch the holes that will be used to cut the opening in the bed. If the vehicle is equipped with a bed liner, a section of the bed liner must be cut away so that the gooseneck platform can contact the bed corrugations.

Template p/n 5978 for use with 6300 head
 Template p/n 114234 for use with 8339 head
 Template p/n 114523 for use with 83399/83391 heads

Durable and reusable stainless steel templates are also available. A time saver for cutting bed liner and bed.
 Template p/n 6467 for use with 6300 head
 Template p/n 6425 for use with 8339 head
 Template p/n 58384 for use with 83399/83391 heads

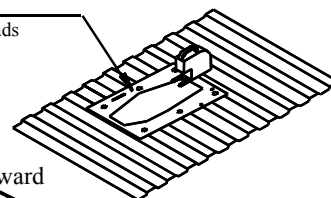

Figure 12

Installation Instructions

GOOSENECK MOUNTING KIT

Part Numbers:

4434

Chevrolet/GMC 2500/3500 Heavy Duty
Short & Long Bed

6300/8339/83391/83399 GOOSENECK HITCH INSTALLATION

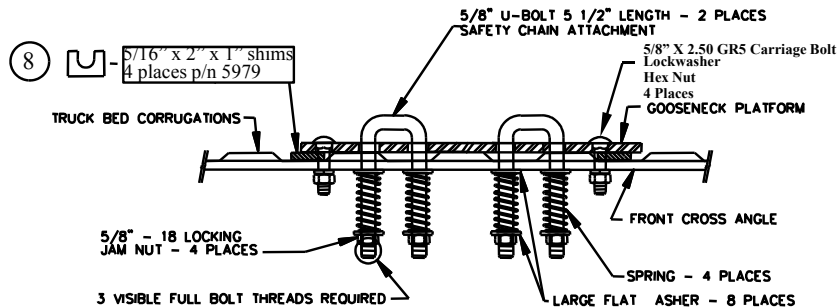



Figure 13

 **WARNING** The fuel tank and/or other vehicle components are located below some of the holes. A wood or metal shield must be placed between the frame and the fuel tank to prevent puncturing the fuel tank when the drill breaks through the bed.

12. Drill 1/4" pilot holes (size will depend on width of blade in saber saw).
13. Cut out the truck bed and the bed hat section on short bed models from underneath the bed of the vehicle and file edges as needed.
14. Install the hitch into the opening.
15. Use the hitch as a guide to drill the forward 5/8" diameter mounting holes. Also, drill 5/8" diameter U-Bolt holes if installing a 6300 or 8339 gooseneck hitch.
16. Before installing the 5/8" carriage bolts through the hitch, the U-block shims must be placed between the hitch and the bed and between the cross members and the bottom of the bed. These shims are necessary to prevent the bed corrugations from collapsing when the bolts are tightened.
17. Install the 5/8 X 2.50 GR5 carriage bolts through the hitch, shims and cross members. Secure with lock washers and nuts. Torque nuts to 150 ft.-lb. (203 N-m).
18. **For 6300 and 8339 Installations:** Install the (2) U-bolts through the hitch and from under the vehicle install the large flat washer over the U-Bolt followed by a spring, another large flat washer and secure with a thin 5/8" jam nut. Repeat for the other legs of the U-bolts. The 5/8" jam nuts are tightened until (3) threads are visible past the bottom of the jam nut.
19. Reinstall the exhaust and the spare tire.