



Installation Instructions

PART NUMBERS: 36572, 90245, 06949



Applications:

Years	Make	Models
-------	------	--------

2016-Current*	Hyundai	Tucson
---------------	---------	--------

*Visit our website for the most up to date information regarding application years and trim levels.

Installation Time: 30MIN

The time listed above is the average time for professional installers. If you do not feel comfortable performing this installation on your own or are in need of assistance, please contact a professional installer.



Representative Vehicle Photo

Equipment Required:

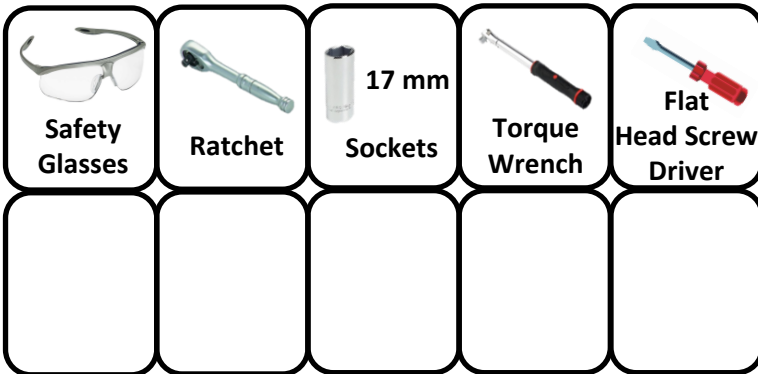

DO NOT EXCEED LOWER OF TOWING VEHICLE MANUFACTURER'S RATING OR:

Hitch Type	Max Gross Trailer Weight	Max Tongue Weight
Weight Carrying	3500 lb. (1589 kg)	300lb. (136kg)
Weight Distributing	X	X

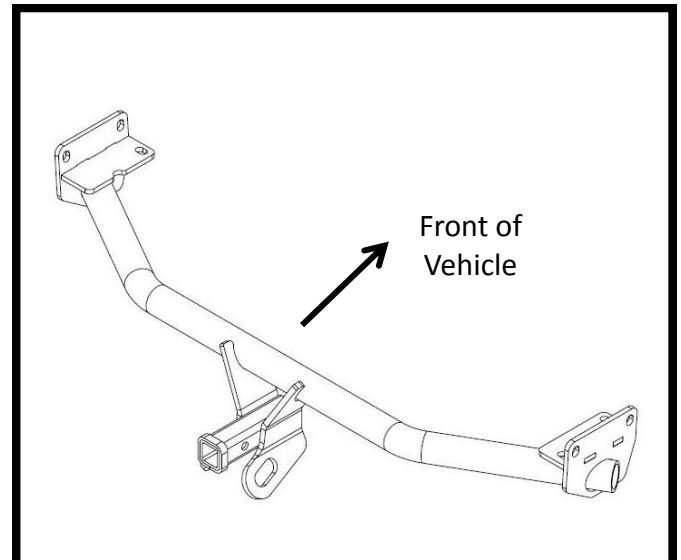

Hitch Illustration



Always wear SAFETY GLASSES
when installing hitch

Installation Instructions

PART NUMBERS: 36572, 90245, 06949

Authorized Drawbar Kit:

36051 (Sold Separately)
Drawbar must be used in
the RISE position.

Fastener Kit: 36572F

①	Qty. (7)	Bolt M10 X 1.25 X 30mm CL10.9
②	Qty. (7)	Conical Tooth Washer 3/8" 

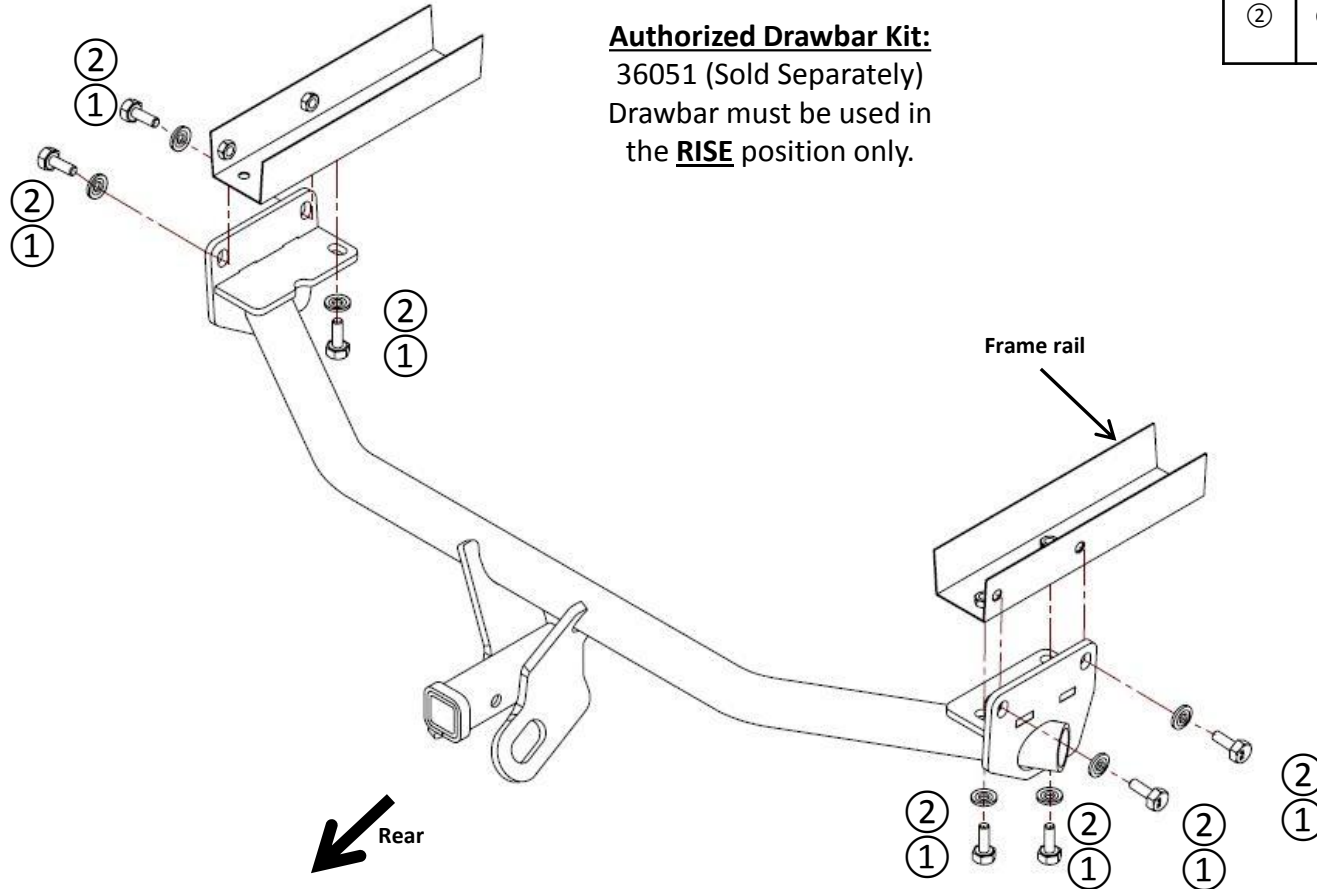

Figure 1

Underbody Panel Removal

1. If equipped remove (2) plastic underbody panels, 1 each side located under the rear bumper and behind the rear wheels. Using a standard screwdriver, remove 3 plastic expansion fasteners from each panel and pull down to remove. Set aside for reinstallation later.

Hitch Installation

1. Start by inserting the hitch over the tailpipe on the passenger side. **Note: removing the rubber isolators and lowering the exhaust may make this easier.** Rotate the hitch and raise into position. Install (4) M10 x 1.25 X 30mm CI10.9 bolts and conical toothed washers (teeth side against hitch) on the passenger side and (3) M10 x 1.25 X 30mm CI10.9 bolts and conical toothed washers (teeth side against hitch) on the driver side.
2. **Tighten all M10 fasteners with torque wrench to 42Lb.-Ft. (57N*M)**

 Proper torque is needed to keep the hitch secure to the vehicle when towing.

3. Re-install the (2) plastic panels if removed earlier.

Note: check hitch frequently, making sure all fasteners and ball are properly tightened. If hitch is removed, plug all holes in trunk pan or other body panels to prevent entry of water and exhaust fumes. A hitch or ball which has been damaged should be removed and replaced.

Observe safety precautions when working beneath a vehicle and wear eye protection. Do not cut access or attachment holes with a torch.

1. If equipped remove (2) plastic underbody panels, 1 each side located under the rear bumper and behind the rear wheels. Using a standard screwdriver, remove (3) plastic expansion fasteners from each panel and pull down to remove. Set aside for reinstallation later.



2. Start by inserting the hitch over the tailpipe on the passenger side. **Note: removing the rubber isolators and lowering the exhaust may make this easier.** Rotate the hitch and raise into position. Install (4) M10 x 1.25 X 30mm C10.9 bolts and conical toothed washers (teeth side against hitch) on the passenger side and (3) M10 x 1.25 X 30mm C10.9 bolts and conical toothed washers (teeth side against hitch) on the driver side.



3. **Tighten all M10 fasteners with torque wrench to 42Lb.-Ft. (57N*M)**

⚠ Proper torque is needed to keep the hitch secure to the vehicle when towing.



4. Re-install the (2) plastic panels if removed earlier.

