

Installation Instructions

Part Numbers:

36492

90075

06121

Ford Taurus All-Including SHO

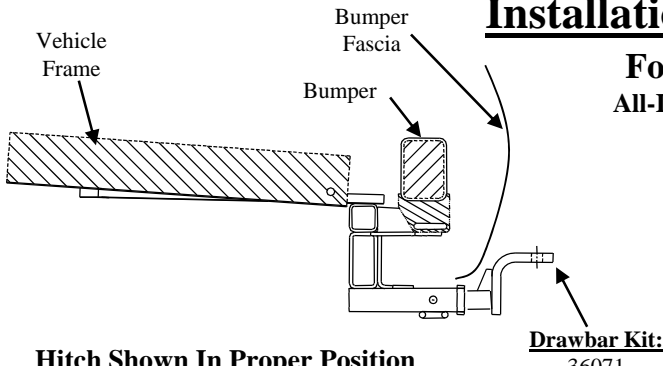

Hitch Shown In Proper Position

Do Not Exceed Lower of Towing Vehicle Manufacturer's Rating or

Hitch type	Max Gross Trailer WT (LB)	Max Tongue WT (LB)
Weight Carrying Ball Mount	3500 (1589 Kg)	300 (136 Kg)

Drawbar must be used in the **Rise** position only.

Wiring Access Location: PC3 , PC4

Equipment Required:

- Fastener Kit:** 36492F
- Wrenches:** 18mm, 3/4", 7/8"
- Drill Bits:** 1/2"
- Other items:** Spray lubricant

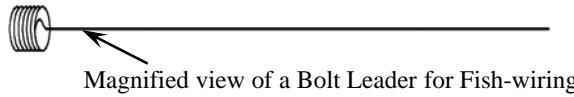

Lower exhaust system, (not shown), for ease of installation,

Fasteners Typical Both Sides of Vehicle

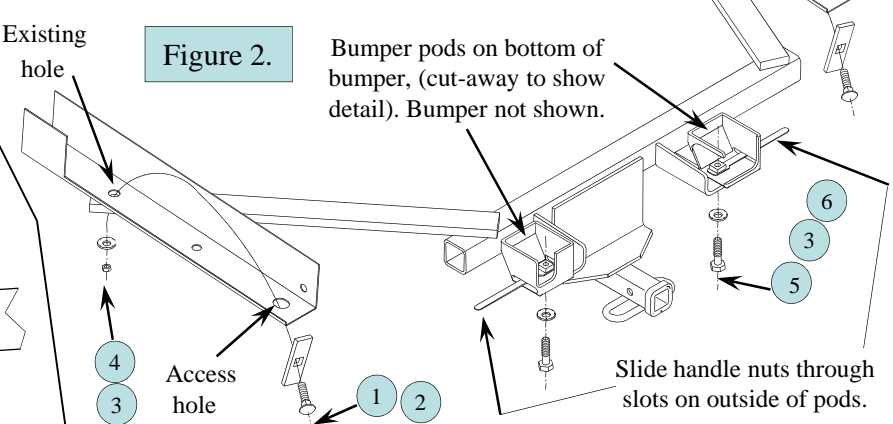
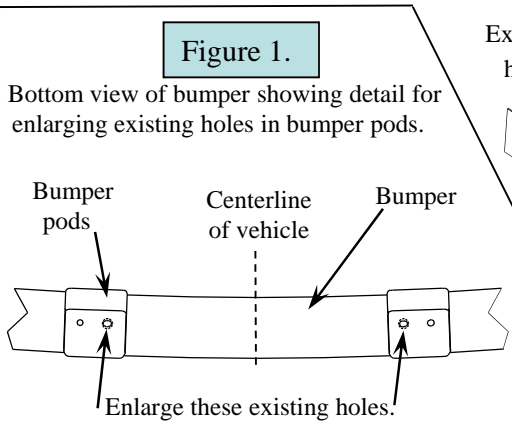
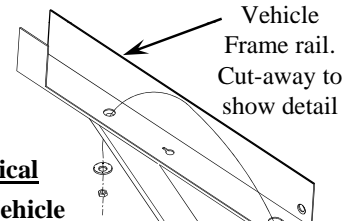

1	Qty. (2)	Carriage Bolt, 1/2"-13 X 1-3/4" Gr. 5	4	Qty. (2)	Hex Nut, 1/2"-13
2	Qty. (2)	Carriage Block, 1/4" X 1" X 3"	5	Qty. (2)	Hex Bolt, 1/2"-13 X 1-1/4" Gr.5
3	Qty. (4)	Conical Toothed Washer, 1/2"	6	Qty. (2)	*Handle-Nut, 1/2"-13 (See torque specs below)

1. Remove plastic push rivets holding bumper fascia straps to bumper pods both sides. Bend fascia straps down. Drill out existing holes in bottom of bumper pods as shown in **Figure 1** above. Be sure to drill out the elongated holes toward the center of vehicle on both bumper pods.
2. Temporarily lower exhaust system by removing the rubber isolators off of the muffler hanger on vehicle frame and below rear axle. On dual muffler remove Passenger side hanger bracket. It helps to spray a lubricant on rubber isolators to aid in removal.
3. Fish-wire 1/2" Carriage bolts and blocks through large access holes in bottom of vehicle frame and down through 3/4" holes in bottom of vehicle frame as shown in **Figure 2** above. Typical both sides of vehicle.
4. Raise hitch into position over the muffler(s) and exhaust pipe(s) aligning the holes in the hitch over the bolts previously installed in **Step 3**. Be careful not to push bolts back up into frame. Loosely install the 1/2" conical toothed washers & nuts.
5. Holding hitch up against bottom of bumper pods align holes in hitch with previously drilled out holes in bumper pods from **Step 1**. If necessary run drill bit up through hitch and bumper to align.
6. Install 1/2" hex bolts & conical washers up through hitch and through bumper brackets into handle-nuts as shown above.
7. Center hitch on vehicle and tighten fasteners to specifications below.
8. Raise exhaust system back into position, re-attaching hanger bracket if removed and rubber isolators including under axle. Also re-attach plastic bumper fascia straps and rivets removed in **Step 1**.

Tighten 1/2"-13 Gr.5 bolts with torque wrench to 75 Lb.-Ft. (102 N*M) *Tighten 1/2"-13 Gr. 5 bolts into handle-nuts to 50 Lb.-Ft. (68 N*M).