



Installation Instructions GOOSENECK MOUNTING KIT

Ford Super Duty

F-250/F-350/ F-450

Part Numbers:

4494

WARNING: Under no circumstances do we recommend exceeding the towing vehicle manufacturers recommended vehicle towing capacity.

Equipment Required:

Fastener Kit: 4494F, 58534

Wrenches: 3/4", 13/16", 15/16", 10mm 13mm

Drill Bits: 3/16", 9/16", 3-1/2" HOLE SAW

Other Tools: Drill, Torque Wench, Center Punch, Tapered Alignment Pin

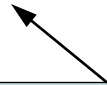

Vehicle Forward

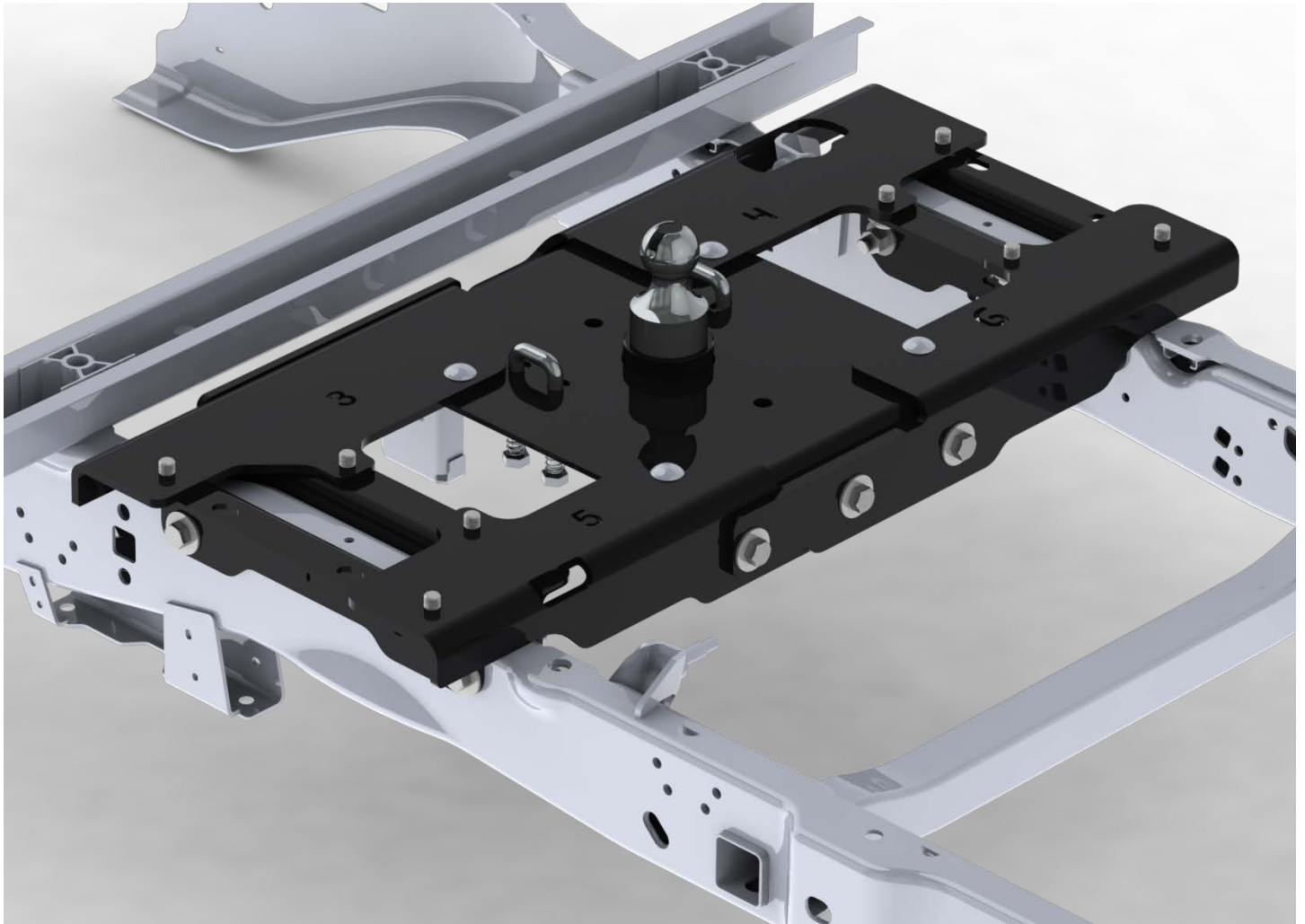

NOTES:

- This rail kit can be used with a 9468 head only.
- Always make sure the ball is fully locked before towing.
- Keep the ball and ball sleeve well lubricated.
- Periodically check and re-torque all the hitch fasteners.
- Check ball, hitch coupler, safety chains and other connections for proper operation every time you tow.

Warning:

- ❖ The tow vehicle manufacturers recommended towing capacities should **UNDER NO CIRCUMSTANCES** be exceeded.
- ❖ Check for adequate clearance between the gooseneck trailer and the rear of the cab and the rear of the truck box before installing hitch.
- ❖ All trucks have fuel lines, brake lines and electrical wiring located along the vehicle frame where the rail kit installs. Carefully examine the location of fuel lines, brake lines and electrical wires before installation and be certain not to damage these when positioning the hitch components. Be careful when drilling holes, cutting sheet metal and tightening fasteners as to not limit the integrity of these systems.

Frame Bracket Installation-Figure 1

1. Lower the spare tire for more space underneath the vehicle.
2. Lower the exhaust system by unbolting the rear exhaust hanger bracket from the frame, and loosening next two forward exhaust hanger brackets. Note: the exhaust will have to be lowered from rearward of the catalytic converter only, support as required.
3. Lower the electrical & brake line hanger on the driver side of the frame, and allow the hanger to loosely hang in place.
4. Install the frame brackets to the truck frame.
 1. Some trucks may come equipped from the factory with frame brackets that are welded to the inside of the frame. If the truck is equipped with the inside frame brackets, you will not need to install the inside frame brackets provided with this mounting kit.
 2. Loosely attach one frame bracket on the outside and inside of the driver side of the vehicle using (2) 5/8-11 x 4.25 GR.8 Hex Head Bolts (#3), (2) 5/8" dia. flat washer (#4), (2) 5/8" dia. conical washer (#5) & (2) 5/8-11 GR.8 hex nuts (#6). Both the inside and outside frame brackets for the driver side will be (#1) brackets.
 3. Loosely attach one frame bracket on the outside and inside of the passenger side of the vehicle using (2) 5/8-11 x 4.25 GR.8 Hex Head Bolts (#3), (2) 5/8" dia. flat washer (#4), (2) 5/8" dia. conical washer (#5) & (2) 5/8-11 GR.8 hex nuts (#6). The passenger side will utilize a (#1) bracket on the outside of the frame, and a (#2) bracket on the inside of the frame.

SOME TRUCKS MAY COME EQUIPPED WITH INSIDE FRAME BRACKETS

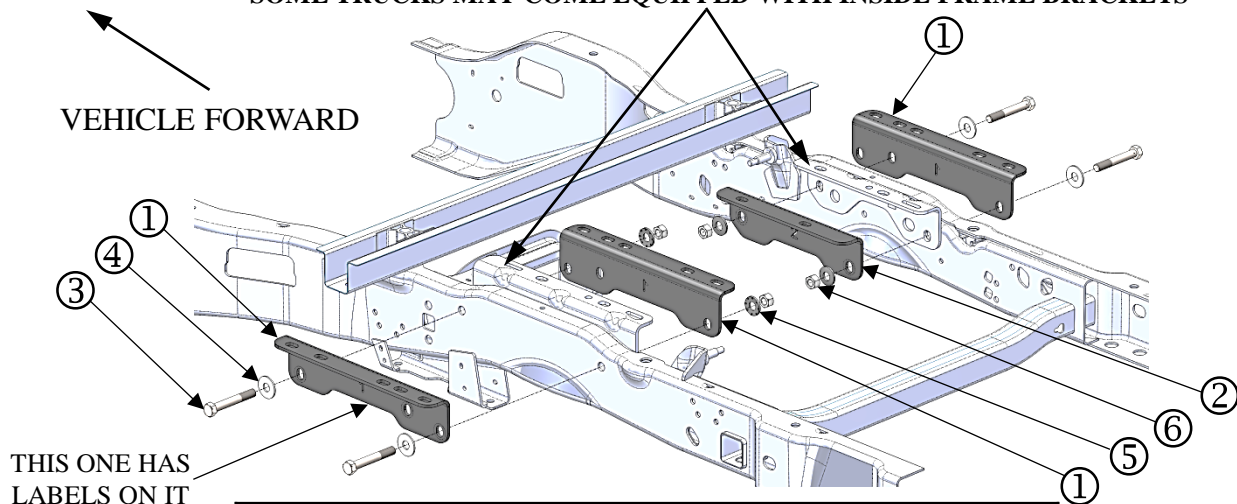

PARTS LIST FOR FRAME BRACKET INSTALLATION		
ITEM NO.	DESCRIPTION	QTY.
1	BRACKET, FRAME LONG (#1)	3*
2	BRACKET. FRAME SHORT (#2)	1*
3	BOLT, HEX HEAD 5/8-11 X 4.25 GR.8	4
4	WASHER, FLAT 5/8" DIA.	4
5	WASHER, CONICAL 5/8" DIA.	4
6	NUT, HEX 5/8-11 GR.8	4

FIGURE 1

Mounting Rail Installation-Figure 2

IMPORTANT-Prior to installing the rails, 1 X (#1) 5/8-11 x 1.50 Gr.8 Carriage bolt needs to be installed in the square hole in each of the frame rails (#'s 3, 4, 5 & 6). These bolts will be used to install the gooseneck center section.

1. Starting with the front passenger side rail (#4), place the rail over top the previously installed passenger side frame brackets. Loosely install the (2) 5/8-11 x 1.25" Gr. 8 hex head bolts (#2) and (2) 5/8" Dia. conical washers (#7) through the frame bracket and into the threaded holes in the rail.
2. Install the rear passenger side rail (#6), place the rail over top the previously installed passenger side frame brackets. Loosely install the (2) 5/8-11 x 1.25" Gr. 8 hex head bolts (#2) and (2) 5/8" Dia. conical washers (#7) through the frame bracket and into the threaded holes in the rail.
3. Install the front driver side rail (#3), place the rail over top the previously installed driver side frame brackets. Loosely install the (2) 5/8-11 x 1.25" Gr. 8 hex Head bolts (#2) and (2) 5/8" Dia. conical washers (#7) through the frame bracket and into the threaded holes in the rail.
4. Install the rear driver side rail (#5), place the rail over top the previously installed driver side frame brackets. Loosely install the (2) 5/8-11 x 1.25" Gr. 8 hex head bolts (#2) and (2) 5/8" Dia. conical washers (#7) through the frame bracket and into the threaded holes in the rail.

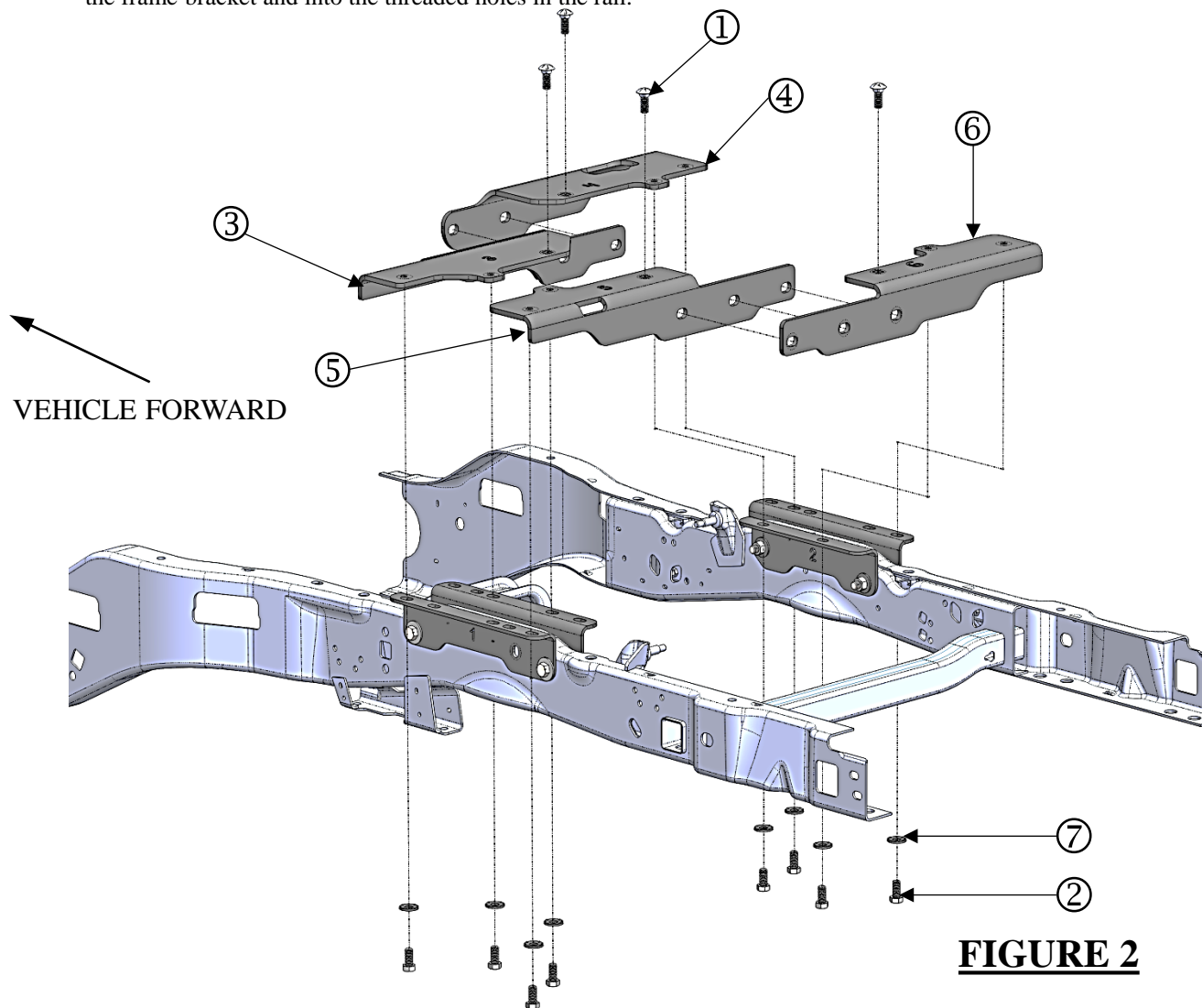

FIGURE 2

PARTS LIST FOR RAIL INSTALLATION		
ITEM NO.	DESCRIPTION	QTY.
1	BOLT, CARRIAGE 5/8-11 X 1.50 GR. 8	4
2	BOLT, HEX HEAD 5/8-11 X 1.25 GR. 8	8
3	RAIL, FRONT DRIVER SIDE (#3)	1
4	RAIL, FRONT PASSENGER SIDE (#4)	1
5	RAIL, REAR DRIVER SIDE (#5)	1
6	RAIL, REAR PASSENGER SIDE (#6)	1
7	WASHER, CONICAL 5/8" DIA.	8

GOOSENECK CENTER SECTION INSTALLATION-Figures 3 & 4.

Note - This step may require an extra set of hands, as the gooseneck center section is very heavy and it will be hard to hold the part in place as you attach the washers and nuts to secure the center section in position.

- Step 1, **Figure 3**. From underneath the vehicle, raise the gooseneck center section (#1) up to the bottom side of the rails as shown and route the carriage bolts previously installed in the rails (page 3 fig. 2) through the 4 outside holes in the center section, and secure using (4) 5/8" dia. conical washer (#2) and (4) 5/8-11 Gr. 8 hex nut (#3).
- Step 2, **Figure 4**. Install the (7) 5/8-11 X 2.00 Gr. 8 hex bolts (#1) , (7) 5/8" dia. flat washers (#2), (7) 5/8" dia. conical washers (#3) & (7) 5/8-11 Gr. 8 hex nuts (#4) as shown through the rails and the center section. It may be necessary to utilize the tapered alignment pin (not included) in order to properly align the holes and slots to be able to securely fasten these parts with the fasteners.

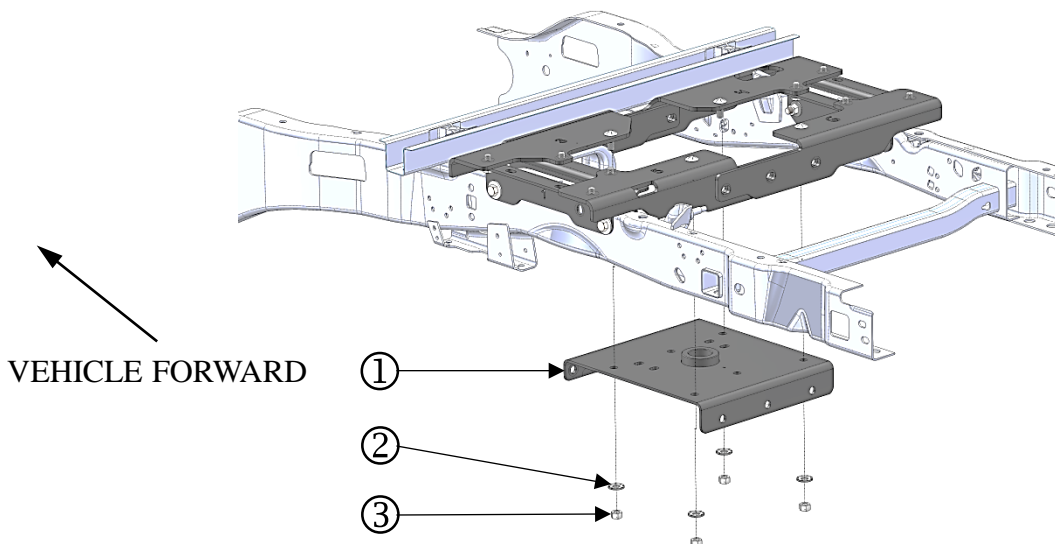

FIGURE 3

PARTS LIST FOR CENTER SECTION INSTALLATION – STEP 1		
ITEM NO.	DESCRIPTION	QTY.
1	GOOSENECK CENTER SECTION	1
2	WASHER CONICAL 5/8" DIA.	4
3	NUT, HEX 5/8-11 GR. 8	4

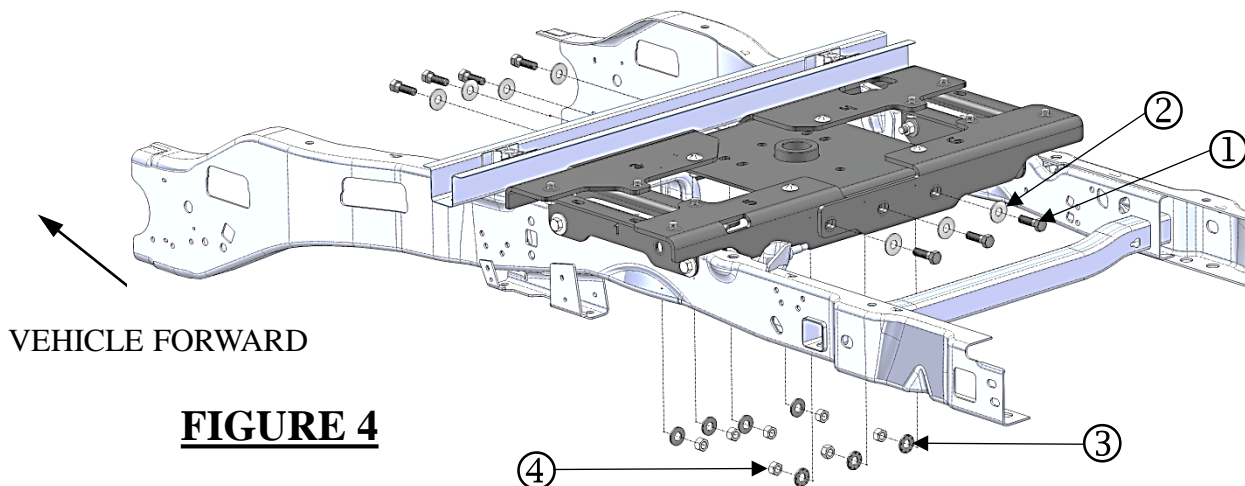
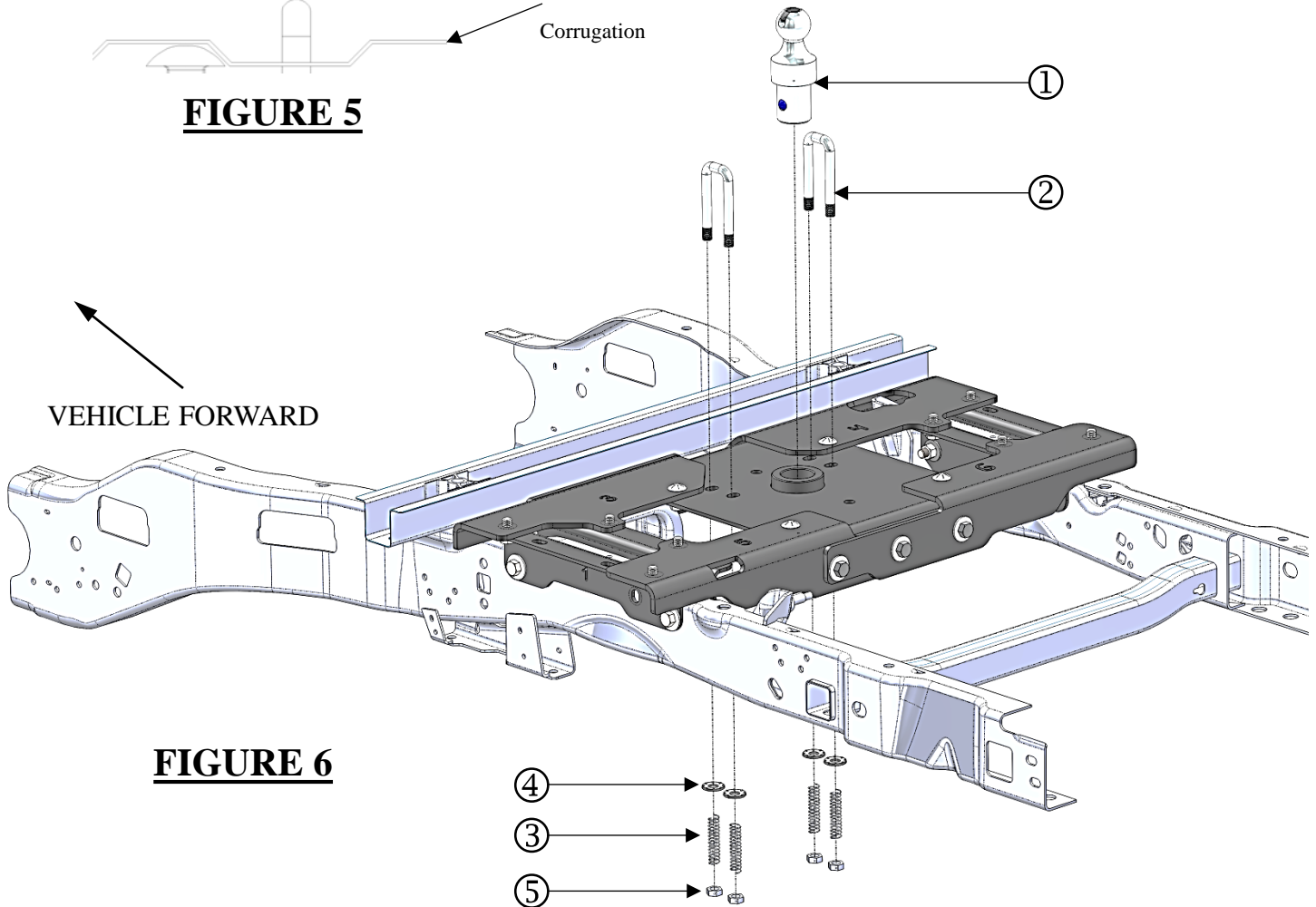
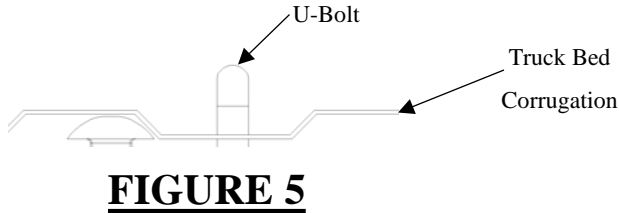

FIGURE 4

PARTS LIST FOR CENTER SECTION INSTALLATION – STEP 2		
ITEM NO.	DESCRIPTION	QTY.
1	BOLT, HEX HEAD 5/8-11 x 2.00 GR. 8	7
2	WASHER, FLAT 5/8" DIA. WASHER	7
3	WASHER, CONICAL 5/8" DIA.	7
4	NUT, HEX 5/8-11 GR.8	7

GOOSENECK SAFETY CHAIN U-BOLT AND BALL INSTALLATION - Figures 5 & 6

1. Using the dimple in the center flat spot of the truck bed as a guide, drill the hole for the gooseneck ball using the 3-1/2" Hole Saw. Clean up all metal shavings and touch up the drilled hole in the bed with paint
2. Install the 1" Hi-Rise 2-5/16" Dia. Elite gooseneck ball in the gooseneck sleeve.
3. Using the U-Bolts slots as a guide, from underneath the truck, mark and center punch the position of the 4 holes in the truck bed that the safety chain attachment U-bolts will be routed through. **THESE HOLES MUST BE IN A LOWER BED CORRIGATION TO LIMIT THE AMOUNT OF THE U-BOLT SHOWING ABOVE THE BED. SEE FIGURE 5.** Then drill 4 pilot holes with a 3/16" drill bit before enlarging these holes to 11/16". Touch up the drilled holes with paint.
4. Install the U-bolts from the topside of the truck bed.
5. From under the truck, install the 5/8" Dia. Conical washers, compression springs, and 5/8-18 lock nuts. Tighten the lock nuts so that there is a minimum of 3 threads showing past the nuts.



PARTS LIST FOR CENTER SECTION INSTALLATION – STEP 2

ITEM NO.	DESCRIPTION	QTY.
1	GOOSENECK BALL, 1" HI-RISE 2-5/16"	1
2	U-BOLT, 5/8-18 X 4.50	2
3	SPRING, COMPRESSION	4
4	WASHER, 5/8 DIA.	4
5	LOCKNUT, HEX 5/8-18	4

FASTENER TORQUE SEQUENCE - FIGURES 7 & 8

1. Torque all fasteners in the following order- **Figure 7**

1. Torque Center Section Carriage Bolts (4) 5/8-11 x 2.00 GR.8 Carriage Bolts to 212FT-LBS (1)
2. Torque Center Section Hex Bolts (7) 5/8-11 x 2.00 GR.8 Hex Head Bolts to 212 FT-LBS (2)
3. Torque Rail Hex Bolts (8) 5/8-11 x 1.50 GR.8 Hex Head Bolts to 150 FT-LBS (3)
4. Torque Mounting Bracket Bolts (4) 5/8-11 x 4.250 GR.8 Hex Head Bolts to 212 FT-LBS (4)

VEHICLE FORWARD

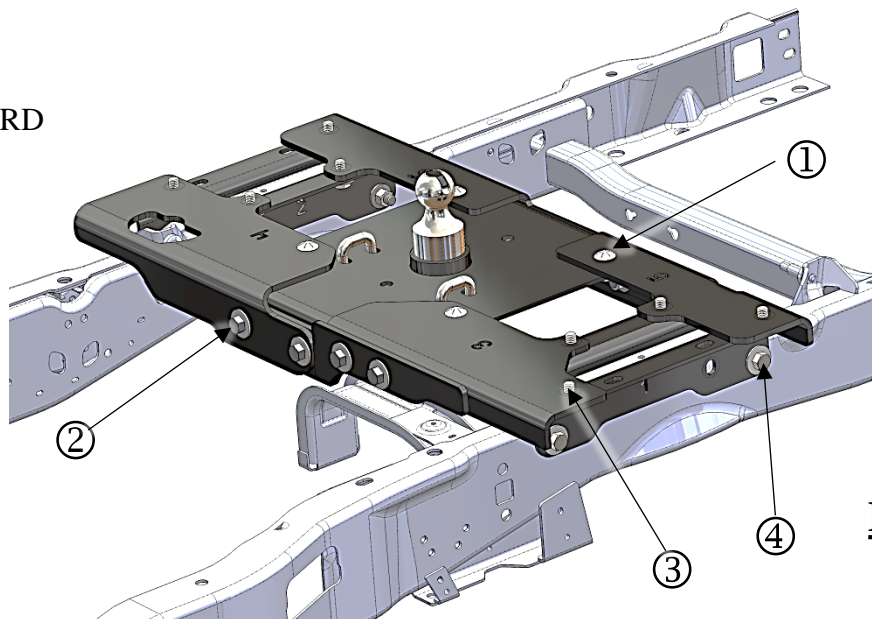
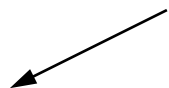

FIGURE 7

VEHICLE FORWARD

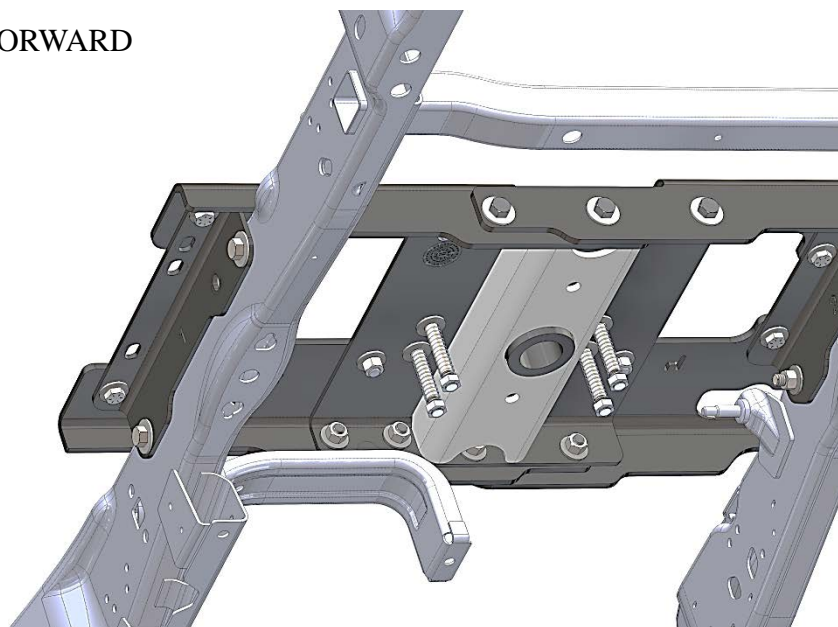

FIGURE 8

REPLACE ALL TRUCK EQUIPMENT REMOVED OR LOWERED

1. **RAISE EXHAUST SYSTEM BACK IN TO POSITION, REPLACE AND TIGHTEN ANY BOLTS REMOVED OR LOOSENED PREVIOUSLY.**
2. **RAISE THE BRAKE & ELECTRICAL HANGER BACK INTO POSITION AND REPLACE AND TIGHTEN ANY BOLTS REMOVED OR LOOSENED PREVIOUSLY.**
3. **RAISE THE SPARE TIRE BACK INTO POSITION.**

Check out a selection of trailer hitches and towing offered in our online store.