



# Installation Instructions

PART NUMBERS: 76209, 84209, CQT76209

## Applications:

| Years         | Make   | Models    |
|---------------|--------|-----------|
| 2018-Current* | Subaru | Crosstrek |
| 2018-Current* | Subaru | Impreza   |

## Installation Time: 60 min

The time listed above is the average time for professional installers. If you do not feel comfortable performing this installation on your own or are in need of assistance, please contact a professional installer.



Representative Vehicle Photo

## Equipment Required:

|   |   |  |   |   |
|---|---|--|---|---|
| <br>Safety Glasses               | <br>Ratchet                      | <br>11/16"<br>Sockets | <br>6" Socket<br>Extension | <br>Universal<br>Joint<br>Socket |
| <br>Exhaust<br>Removal<br>Pliers | <br>Flat<br>Head Screw<br>Driver | <br>Torque<br>Wrench  | <br>Utility<br>Knife       |   |

## DO NOT EXCEED LOWER OF TOWING VEHICLE MANUFACTURER'S RATING OR:

| Hitch Type          | Max Gross Trailer Weight | Max Tongue Weight |
|---------------------|--------------------------|-------------------|
| Weight Carrying     | 4500 lb. (2043 kg)       | 675 lb. (306 kg)  |
| Weight Distributing | N/A                      | N/A               |

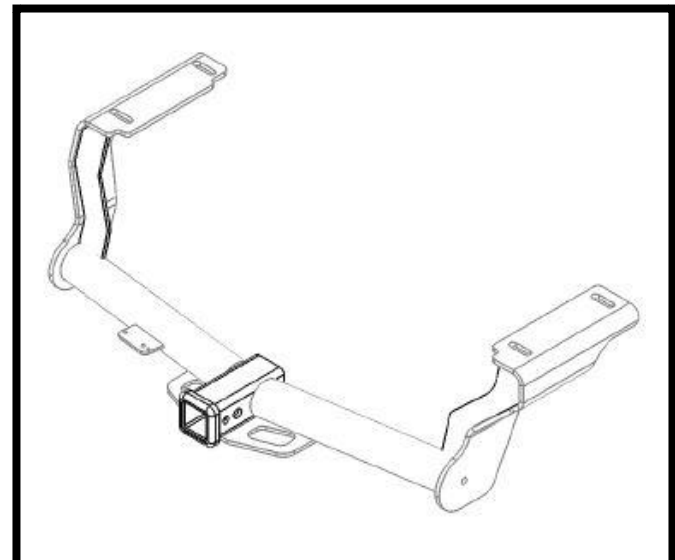

Hitch Illustration



Always wear **SAFETY GLASSES** when installing hitch

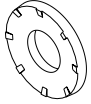

**Conical Washer**  
Teeth side  
Against hitch

# Installation Instructions

## PART NUMBERS: 76209, 84209, CQT76209

**Fastener Kit: 76209F**

|   |          |   |  |
|---|----------|---|--|
| ① | Qty. (4) | Pull wire 7/16<br>Part no. 5481               |  |
| ② | Qty. (4) | Conical Tooth<br>Washer 7/16"                 |  |
| ③ | Qty. (4) | Hex Nut<br>7/16-14                            |  |
| ④ | Qty. (4) | Block 7/8"x2"<br>Part no. 01204               |  |
| ⑤ | Qty. (4) | Carriage Bolt<br>7/16 - 14 x 1.50             |  |
| ⑥ | Qty. (2) | Block .250 x 1.50 x 2.00<br>Part no. 01097002 |  |

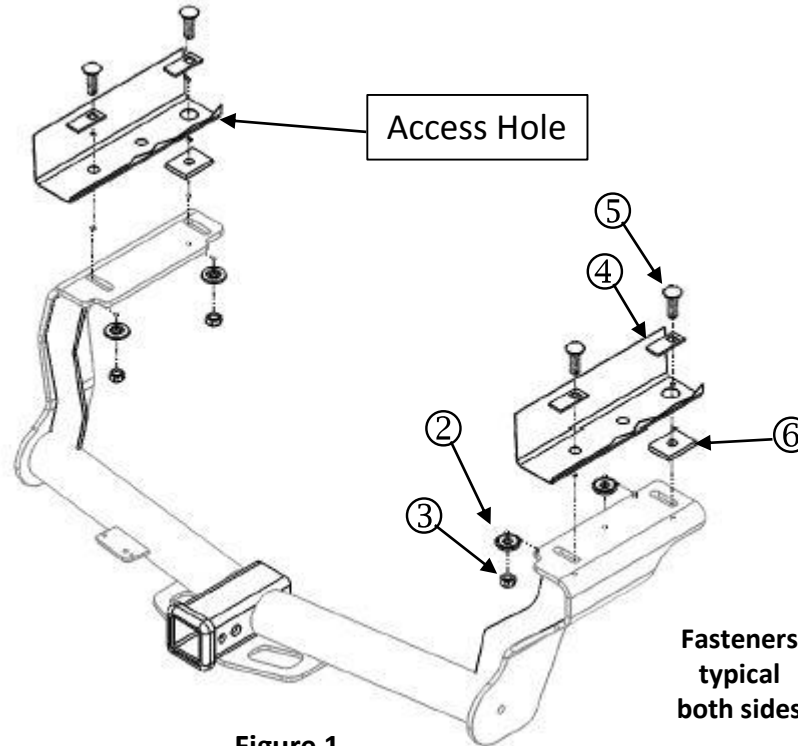

**Figure 1**

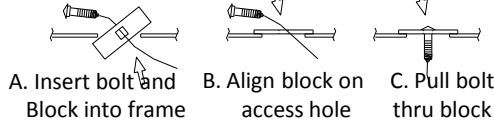

**Figure 3**

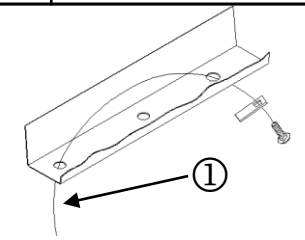

Kink pullwire to keep spacer independent of bolt

**Figure 2**

- 1. Lower muffler** – Using the exhaust removal pliers, lower muffler by removing the (4) rearmost rubber hangers. There are (2) hangers on the left side of the exhaust, (1) on the right side of the exhaust, and (1) in the middle of the car. **Note:** A spray of lubricant on rubber hangers makes them slide off metal pins more easily. **NOTE:** Be careful that exhaust is supported before removing rubber hangers.
- 2. Remove rubber plugs** -- Using a flat screw driver, remove (2) rubber plugs, rear and forward, from the holes in the bottom of the frame on each side of the car, return plugs to customer. Using a utility knife, remove the excess caulk near the access hole. **Note:** Reseal if seam is exposed.
- 3. Install fasteners** – Feed the coiled end of pull wire through the rearmost attachment hole and out of the forward most access and attachment hole in the bottom of frame. Attach the 7/16" carriage bolt and 1/10" thick block (item 4) to the pull wire and pull the fasteners into position, both sides. See figure 2. Using the provided pull wire, complete the reverse fishwire technique as seen in figure 3.
- 4. Using tape, install block** (part. 01097002) between the hitch and the frame at the access hole.
- 5. Install hitch** – Raise hitch into position being careful not to push fasteners back into the frame. Loosely install the conical washers (item 2) and hex nuts (item 3) onto carriage bolts, (4) places.
- 6. Tighten all 7/16-14 Gr5 fasteners with torque wrench to 50 Lb.-Ft. ( 68 N\*M).** **Note:** a universal joint socket may be required to tighten the rearmost bolts.



Proper torque is needed to keep the hitch secure to the vehicle when towing.

- 7. Raise muffler** – raise muffler back into position and reattach rubber hangers, (2) per side and (1) in the middle.

Note: check hitch frequently, making sure all fasteners and ball are properly tightened. If hitch is removed, plug all holes in trunk pan or other body panels to prevent entry of water and exhaust fumes. A hitch or ball which has been damaged should be removed and replaced. Observe safety precautions when working beneath a vehicle and wear eye protection. Do not cut access or attachment holes with a torch. This product complies with safety specifications and requirements for connecting devices and towing systems of the state of New York, V.E.S.C. Regulation V-5 and SAE J684.

**1. Lower muffler** – Using the exhaust removal pliers, lower muffler by removing the (4) rearmost rubber hangers. There are (2) hangers on the left side of the exhaust, (1) on the right side of the exhaust, and (1) in the middle of the car. **Note:** A spray of lubricant on rubber hangers makes them slide off metal pins more easily. **NOTE:** Be careful that exhaust is supported before removing rubber hangers.

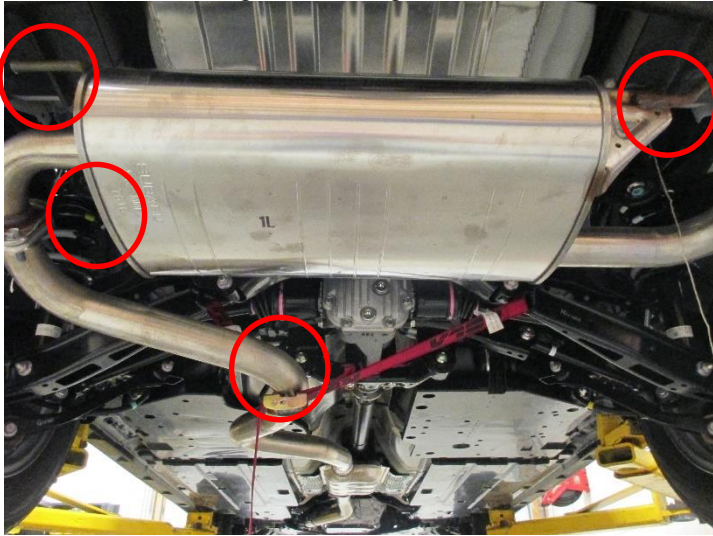

**2. Remove rubber plugs** -- Using a flat screw driver, remove (2) rubber plugs, rear and forward, from the holes in the bottom of the frame on each side of the car, return plugs to customer. Using a utility knife, remove the excess caulk near the access hole. **Note:** Reseal if seam is exposed.

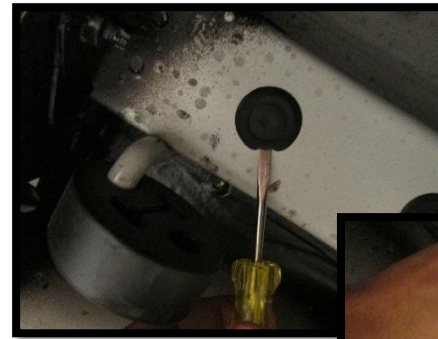

**3. Install fasteners** – Feed the coiled end of pull wire through the rearmost attachment hole and out of the forward most access and attachment hole in the bottom of frame. Attach the 7/16" carriage bolt and 1/10" thick block (item 4) to the pull wire and pull the fasteners into position, both sides. See figure 2. Using the provided pull wire, complete the reverse fishwire technique as seen in figure 3.



**4. Using tape, install block (part. 01097002) between the hitch and the frame at the access hole.**



**5. Install hitch** – Raise hitch into position being careful not to push fasteners back into the frame. Loosely install the conical washers (item 2) and hex nuts (item 3) onto carriage bolts, (4) places.



**6. Tighten all 7/16-14 Gr5 fasteners with torque wrench to 50 Lb.-Ft. ( 68 N\*M).** **Note:** a universal joint socket may be required to tighten the rearmost bolts.



**7. Raise muffler** – raise muffler back into position and reattach rubber hangers, (2) per side and (1) in the middle.



**⚠ Proper torque is needed to keep the hitch secure to the vehicle when towing.**

Check out a selection of trailer hitches and towing offered in our online store.