



Installation Instructions

PART NUMBERS: 76184, 84184, CQT76184

Applications:

Years	Make	Models
2018-Current*	Chevrolet	Traverse
2018-Current*	Buick	Enclave

Installation Time: 75 min.

The time listed above is the average time for professional installers. If you do not feel comfortable performing this installation on your own or are in need of assistance, please contact a professional installer.



Representative Vehicle Photo

Equipment Required:

Safety Glasses	Ratchet	T15 torx T20 torx 7mm 15mm 3/4" Sockets	Torque Wrench
6" Socket Extension	Plastic Trim Tools		

**DO NOT EXCEED LOWER OF TOWING VEHICLE
MANUFACTURER'S RATING OR:**

Hitch Type	Max Gross Trailer Weight	Max Tongue Weight
Weight Carrying	5000 lb. (2270 Kg)	750 lb. (340 Kg)
Weight Distributing	5000 lb. (2270 Kg)	750 lb. (340 Kg)

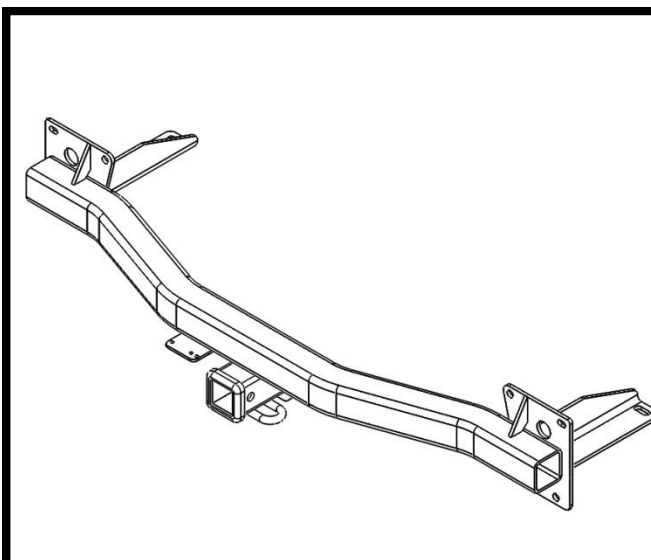

Hitch Illustration

Always wear SAFETY GLASSES when installing hitch

Installation Instructions

PART NUMBERS: 76184, 84184, CQT76184

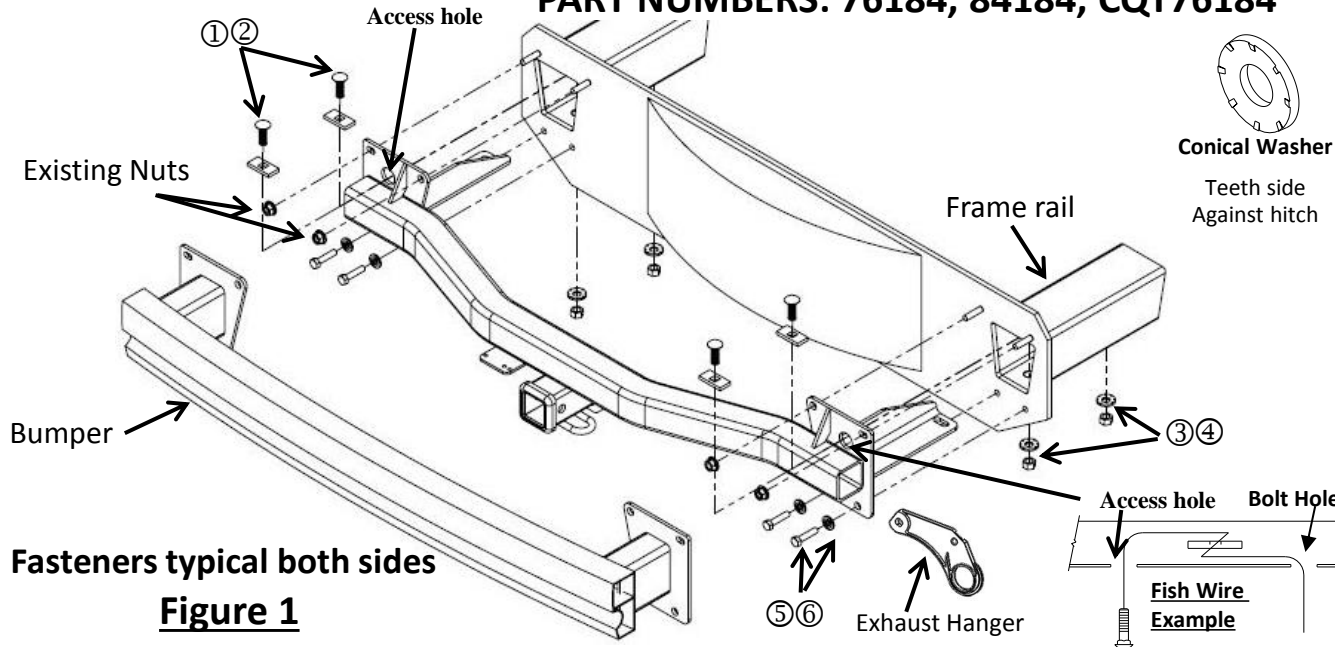

Fastener Kit: 76184F		
①	Qty.(4)	Carriage Bolt 1/2"-13 X 1 1/2" GR5
②	Qty.(4)	Spacer 1/4" x 1" x 2" Part No. 5121
③	Qty.(4)	Conical washer 1/2" Part No. 01292008
④	Qty.(4)	Hex Nut 1/2"-13 GR5
⑤	Qty.(4)	Bolt M10 x 1.5 x 45mm Cl10.9
⑥	Qty.(4)	Conical washer 3/8" Part No. 01292006
⑦	Qty. (4)	Fish wire 1/2" Part No. 5482

Fasteners typical both sides
Figure 1

- 1. Remove Fascia** – Open the tailgate. Pry open 4 plastic covers below taillights remove the 4 screws using a 7mm socket, 2 each side. Remove 2 screws that connect the bottom lower edge of the fascia to the metal support tabs using a T20 socket. Remove 8 screws that connect the wheel well liner to the fascia using T15 socket, 4 each side. Gently pull back the wheel well trim, remove 2 screws that connect the fascia to the vehicle body with a 7mm socket, 1 each side. Starting from the wheel well gently pull off fascia. Unplug any wires that are attached.
- 2. Remove bumper (support exhaust)**– Remove 4 M10 nuts with a 15mm socket from the top bumper attachments, set nuts aside for re-attachment, 2 each side. Remove 4 M10 bolts with a 15mm socket from the bottom bumper attachments, 2 each side. Be sure to support the vehicle exhaust system as these bolts also attach the exhaust hangers. Return the bumper and bolts to the vehicle owner.
- 3. Install hitch** – Raise the hitch into position over the bumper studs, install the nuts removed earlier. Raise exhaust hangers into position, install the M10 bolts ⑤ and conical washers ⑥ (teeth side toward hitch). Fishwire the carriage bolts ① and spacers ② into the vehicle frame through the access hole in the hitch, install the conical washers ③ (teeth side toward hitch) and nuts ④.
- 4. Torque fasteners** - **Tighten all ½ GR5" fasteners with torque wrench to 75Lb.-Ft. (102 N*M) and all M10 fasteners to 38Lb.-Ft. (52 N*M)**



Proper torque is needed to keep the hitch secure to the vehicle when towing.

- 5. Re-install fascia** - Reverse the process used in step 1 to re-install the fascia. Be sure to reconnect any plugs that were disconnected.
*Vehicle fascia has a removable panel for hitch usage. Panel may be replaced when hitch is not in use.

Note: check hitch frequently, making sure all fasteners and ball are properly tightened. If hitch is removed, plug all holes in trunk pan or other body panels to prevent entry of water and exhaust fumes. A hitch or ball which has been damaged should be removed and replaced. Observe safety precautions when working beneath a vehicle and wear eye protection. Do not cut access or attachment holes with a torch.

This product complies with safety specifications and requirements for connecting devices and towing systems of the state of New York, V.E.S.C. Regulation V-5 and SAE J684.

Open the tailgate. Pry open 4 plastic covers below taillights remove the 4 screws using a 7mm socket, 2 each side.



Remove 2 screws that connect the bottom lower edge of the fascia to the metal support tabs using a T20 socket.

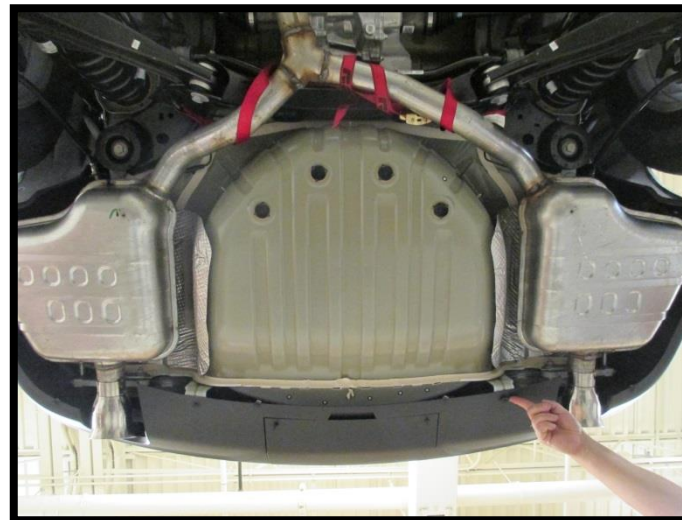

Remove 8 screws that connect the wheel well liner to the fascia using T15 socket, 4 each side. Gently pull back the wheel well trim, remove 2 screws that connect the fascia to the vehicle body with a 7mm socket, 1 each side.



Starting from the wheel well gently pull off fascia. Unplug any wires that are attached.



Remove 4 M10 nuts with a 15mm socket from the top bumper attachments, set nuts aside for re-attachment, 2 each side.



Remove 4 M10 bolts with a 15mm socket from the bottom bumper attachments, 2 each side. Be sure to support the vehicle exhaust system as these bolts also attach the exhaust hangers.

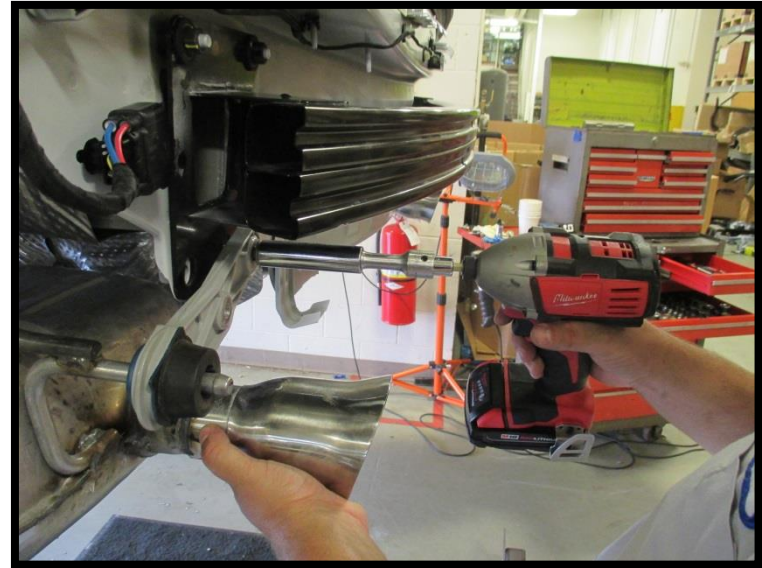

Return the bumper and bolts to the vehicle owner.

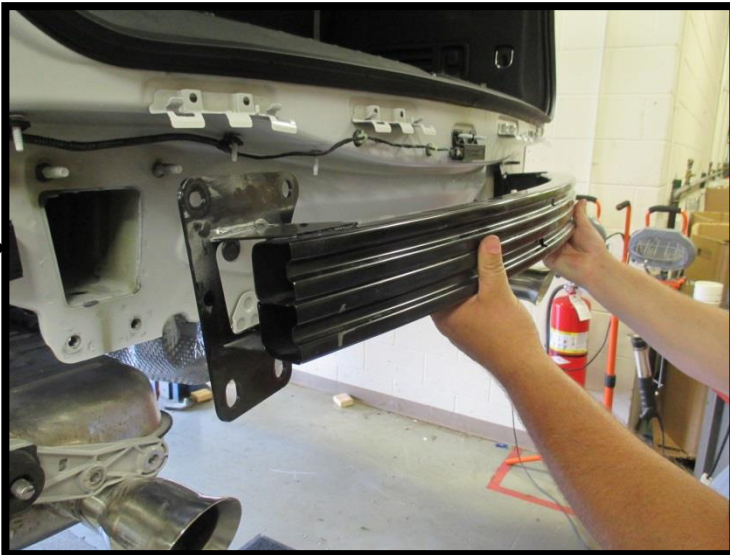

Raise the hitch into position over the bumper studs, install the nuts removed earlier. Raise exhaust hangers into position, install the M10 bolts ⑤ and conical washers ⑥ (teeth side toward hitch).



Fishwire the carriage bolts ① and spacers ② into the vehicle frame through the access hole in the hitch, install the conical washers ③ (teeth side toward hitch) and nuts ④.

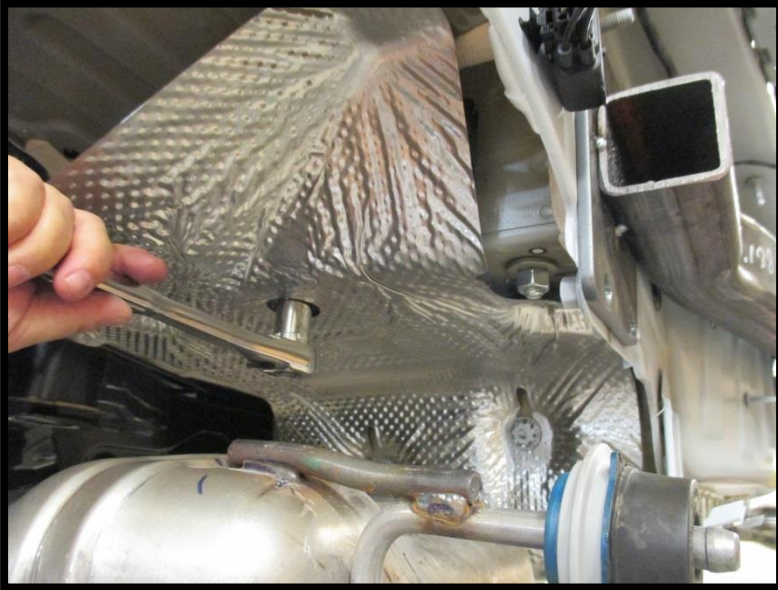

Torque fasteners - Tighten all ½ GR5" fasteners with torque wrench to 75Lb.-Ft. (102 N*M) and all M10 fasteners to 38Lb.-Ft. (52 N*M)

⚠ Proper torque is needed to keep the hitch secure to the vehicle when towing.

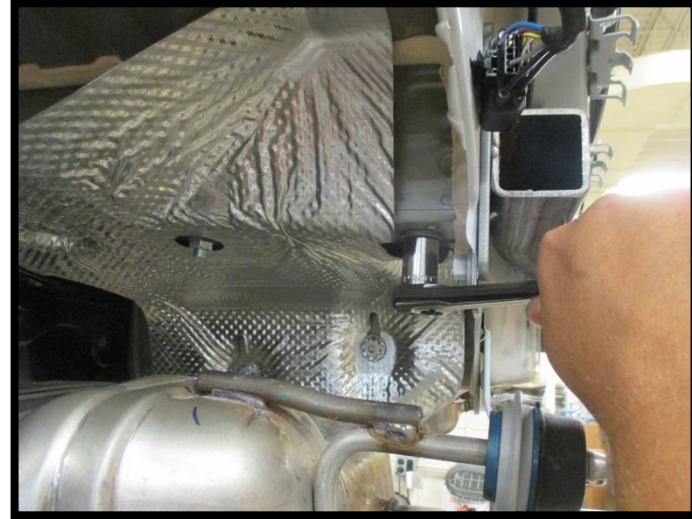

Re-install fascia - Reverse the process used in step 1 to re-install the fascia. Be sure to reconnect any plugs that were disconnected. *Vehicle fascia has a removable panel for hitch usage. Panel may be replaced when hitch is not in use.

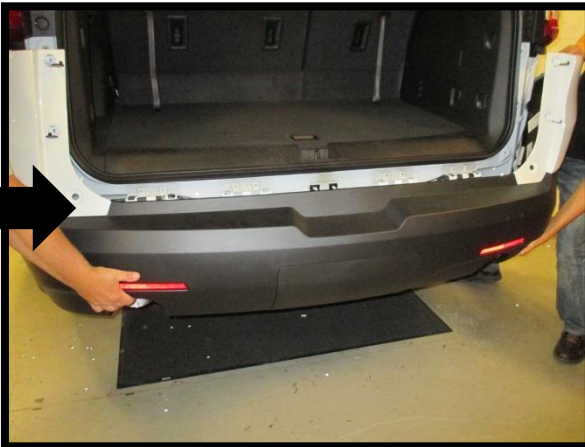

Check out a selection of trailer hitches and towing offered in our online store.