



# Installation Instructions

PART NUMBERS: 76141, 84141, CQT76141

## Applications:

Years	Make	Models
2012-2015	Mercedes	ML350
2016-Current	Mercedes	GLE350





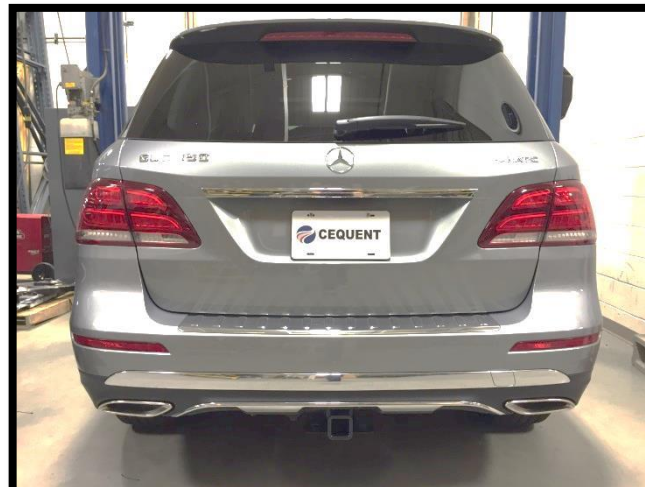



**Installation Time: 40 min.**

The time listed above is the average time for professional installers. If you do not feel comfortable performing this installation on your own or are in need of assistance, please contact a professional installer.



**Representative Vehicle Photo**

## Equipment Required:

 Safety Glasses	 Ratchet	 5mm 8mm 10mm Sockets	 13mm 16mm 3/4" Sockets	 Torque Wrench
 Exhaust Removal Pliers	 E10 External Torxbit	 6" Socket Extension	 Tin Snips	

## DO NOT EXCEED LOWER OF TOWING VEHICLE MANUFACTURER'S RATING OR:

Hitch Type	Max Gross Trailer Weight	Max Tongue Weight
Weight Carrying	7000 lb. (3178 kg)	700 lb. (318 kg)
Weight Distributing	7000 lb. (3178 kg)	700 lb. (318 kg)

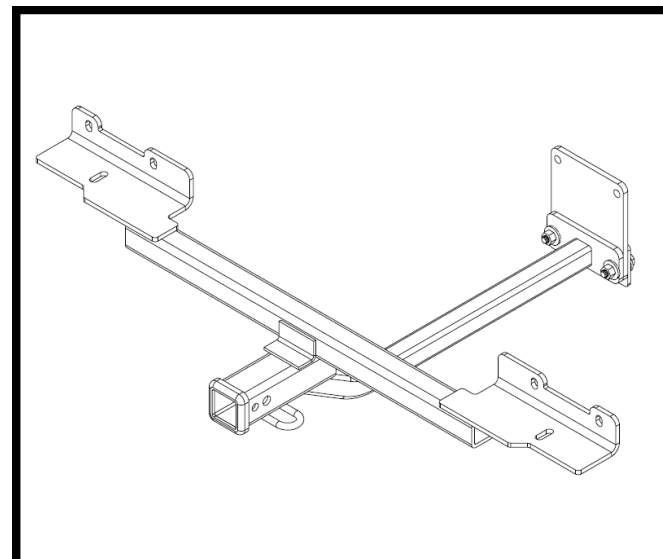





**Hitch Illustration**

**Always wear SAFETY GLASSES when installing hitch**

# Installation Instructions

**PART NUMBERS: 76141, 84141, CQT76141**

**Fastener Kit: 76141F**

①	Qty. (2)	Hex Bolt ½"-13 x 3.5" Gr5	
②	Qty. (6)	Conical washer 1/2"	
③	Qty. (4)	Hex Nut ½"-13 Gr5	
④	Qty. (2)	Carriage Bolt ½"-13 x 1.75" Gr5	
⑤	Qty. (5)	Cable Ties	

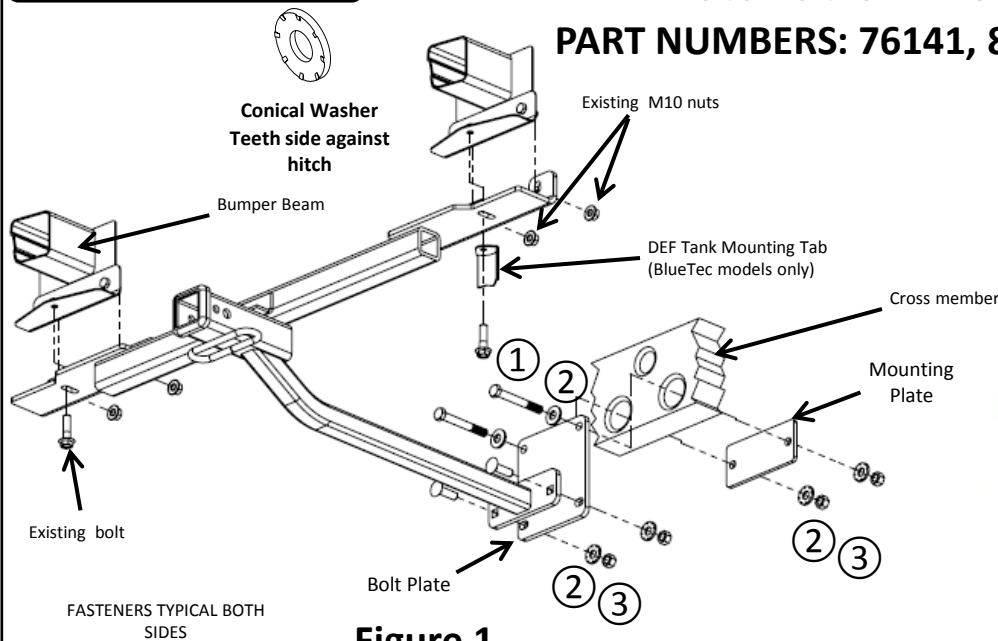

**Figure 1**

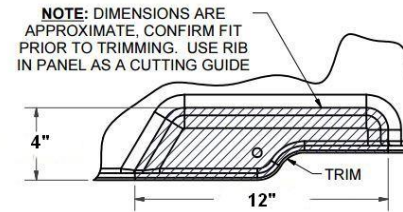

**Figure 2**



**Figure 3**

- 1. Remove DEF Tank shield – (BlueTec vehicles only)** Remove (6) plastic flange nuts using a 10mm socket.
- 2. Remove bumper fascia brackets** – Remove (3) bumper fascia brackets by removing the (4) screws in the lower bumper fascia tabs and (5) nuts using a 10mm socket. 2014 and newer models remove (3) bolts using a 10mm socket to remove the center fascia support bracket. Return brackets and hardware to owner.
- 3. Lower exhaust** – Lower the driver side exhaust by removing the rubber isolator from the hanger using exhaust removal pliers or other suitable tool (spray with soapy water to make this easier) and unbolt the exhaust hanger near the middle of the vehicle using a 13mm socket. Repeat on passenger side if present. Be sure to support exhaust system to prevent damage.
- 4. Remove Heat Shield** – Remove the driver side heat shield by removing (3) formed nuts and (1) bolt using an 8mm socket. Repeat on passenger side if present. 2014 and newer models have a one piece heat shield, remove (6) fasteners using a 5mm socket and (2) E10 torx bolts.
- 5. Lower DEF tank - (BlueTec vehicles only)** Remove the rearmost bolt holding the DEF tank and the rearmost nut securing strap using a 13mm socket. Be sure to support the DEF tank to prevent damage.
- 6. Remove lower bumper bolts** - Remove the lower (2) bolts securing the bumper to the vehicle using a 16mm socket. Repeat for both sides.
- 7. Trim heat shield** – Trim and reinstall heat shields according to Figure 2. Use rib in panel as a cutting guide. **Note:** Dimensions are approximate, confirm fit prior to trimming.
- 8. Install hitch** - Raise hitch into position, secure to the bumper beam studs using the nuts removed in step 6. Center the holes of the hitch with the bumper weldnuts. **BlueTec vehicles only** – raise DEF tank and secure the mounting strap using the hardware that was removed in step 5. Secure the DEF tank mounting tab using the hardware removed in step 5.
- Raise the bolt plate into position and install the supplied carriage bolts through the square holes in the hitch and into the slots of the bolt plate then install the conical tooth washers (teeth side against hitch) and 1/2" hex nuts.
- Raise the mounting plate into position and secure the hitch to the cross member using the 1/2"-13 x 3.5" hex bolts and 1/2" conical toothed washers (teeth side against hitch) and 1/2" hex nuts.
- 11. Tighten M8 fasteners to 25 Lb.-ft. (34 N\*M) and M10 fasteners with torque wrench to 38 Lb.-Ft. (52 N\*M) and 1/2" fasteners to 75 Lb.-ft. (102 N\*M)**

**⚠ Proper torque is needed to keep the hitch secure to the vehicle when towing.**

- 12. Raise exhaust** – Raise and secure the exhaust lowered in step 3.
- 13. Trim and Reinstall DEF tank shield – (BlueTec vehicles only)** Trim 4" from inboard edge of shield (Figure 3) Reinstall DEF tank shield removed in step 1.
- 14. Secure fascia tabs** - Using the cable ties provided attach the fascia tabs to the hitch cross tube.

Note: check hitch frequently, making sure all fasteners and ball are properly tightened. If hitch is removed, plug all holes in trunk pan or other body panels to prevent entry of water and exhaust fumes. A hitch or ball which has been damaged should be removed and replaced. Observe safety precautions when working beneath a vehicle and wear eye protection. Do not cut access or attachment holes with a torch.

This product complies with safety specifications and requirements for connecting devices and towing systems of the state of New York, V.E.S.C. Regulation V-5 and SAE J684.

**Remove DEF Tank shield – (BlueTec vehicles only)** Remove (6) M10 plastic flange nuts .



**Remove bumper fascia brackets –** Remove (3) bumper fascia brackets by removing the (4) 10mm screws in the lower bumper fascia tabs and (5) 10mm nuts. 2014 and newer models remove (3) bolts using a 10mm socket to remove the center fascia support bracket. Return brackets and hardware to owner.



**Lower exhaust –** Lower the driver side exhaust by removing the rubber isolator from the hanger using exhaust removal pliers or other suitable tool (spray with soapy water to make this easier) and unbolt the exhaust hanger near the middle of the vehicle using a 13mm socket. Repeat on passenger side if present. Be sure to support exhaust system to prevent damage.



**Remove Heat Shield –** Remove the driver side heat shield by removing (3) formed nuts and (1) bolt using an 8mm socket. Repeat on passenger side if present. 2014 and newer models have a one piece heat shield, remove (6) fasteners using a 5mm socket and (2) E10 torx bolts.





**Lower DEF tank - (BlueTec vehicles only)** Remove the rearmost bolt holding the DEF tank and the rearmost nut securing strap using a 13mm socket. Be sure to support the DEF tank to prevent damage.



**Remove lower bumper bolts** - Remove the lower (2) bolts securing the bumper to the vehicle using a 10mm socket. Repeat for both sides.



**Trim heat shield** – Trim and reinstall heat shields according to Figure 2. Use rib in panel as a cutting guide. **Note:** Dimensions are approximate, confirm fit prior to trimming.

**NOTE: DIMENSIONS ARE APPROXIMATE, CONFIRM FIT PRIOR TO TRIMMING. USE RIB IN PANEL AS A CUTTING GUIDE**

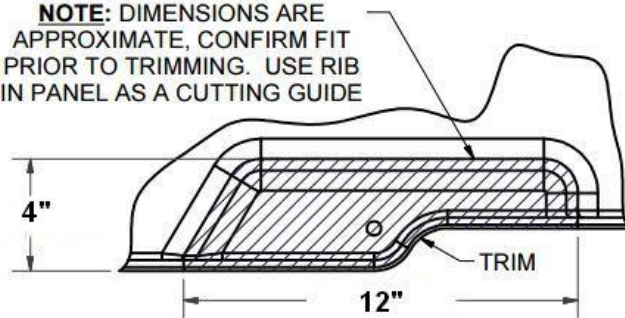

**Install hitch** - Raise hitch into position, secure to the bumper beam studs using the M10 nuts removed in step 6. Center the holes of the hitch with the bumper weldnuts.



**BlueTec vehicles only** – raise DEF tank and secure the mounting strap using the hardware that was removed in step 5. Secure the DEF tank mounting tab using the hardware removed in step 5.



Raise the bolt plate into position and install the supplied carriage bolts through the square holes in the hitch and into the slots of the bolt plate then install the conical tooth washers (teeth side against hitch) and 1/2" hex nuts .



Raise the mounting plate into position and secure the hitch to the cross member using the 1/2"-13 x 3.5" hex bolts and 1/2" conical toothed washers (teeth side against hitch) and 1/2" hex nuts.

**Tighten M8 fasteners to 25 Lb.-ft. (34 N\*M) and M10 fasteners with torque wrench to 38 Lb.-Ft. (52 N\*M) and 1/2" fasteners to 75 Lb.-ft. (102 N\*M)**



**Raise exhaust** – Raise and secure the exhaust lowered in step 3.



**!** Proper torque is needed to keep the hitch secure to the vehicle when towing.

**Trim and Reinstall DEF tank shield – (BlueTec vehicles only)** Trim 4" from inboard edge of shield (Figure 3) Reinstall DEF tank shield removed in step 1.

**Secure fascia tabs** - Using the cable ties provided attach the fascia tabs to the hitch cross tube.

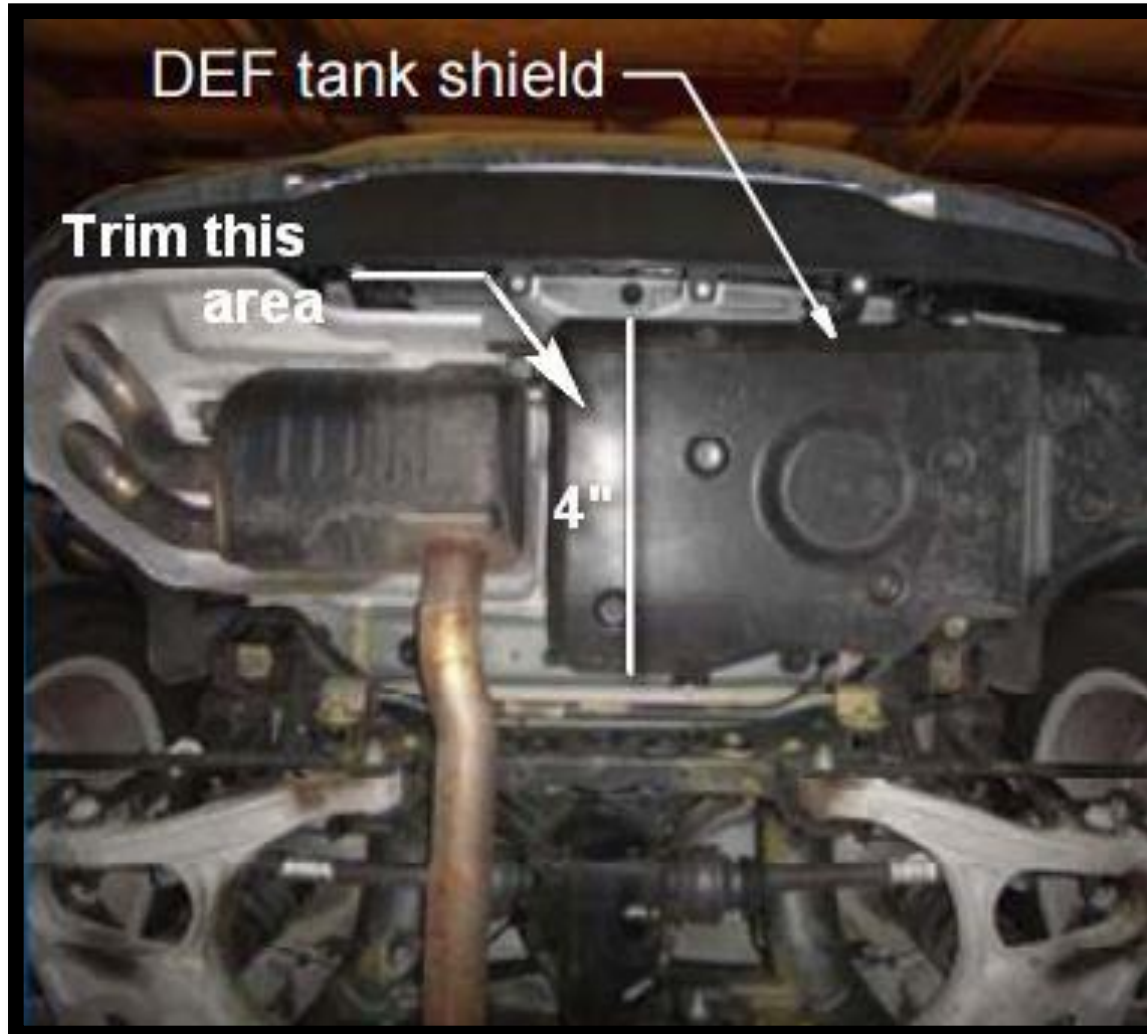

Our website offers you a wide variety of trailer hitches and towing at affordable prices.