

# Installation Instructions

## PART NUMBERS: 65080, CQT65080

### Applications:

Years	Make	Models
2007-Current*	Toyota	Tundra
2007-Current*	Toyota	Sequoia

### Installation Time: **20 min**

The time listed above is the average time for professional installers. If you do not feel comfortable performing this installation on your own or are in need of assistance, please contact a professional installer.



**Representative Vehicle Photo**

### Equipment Required:

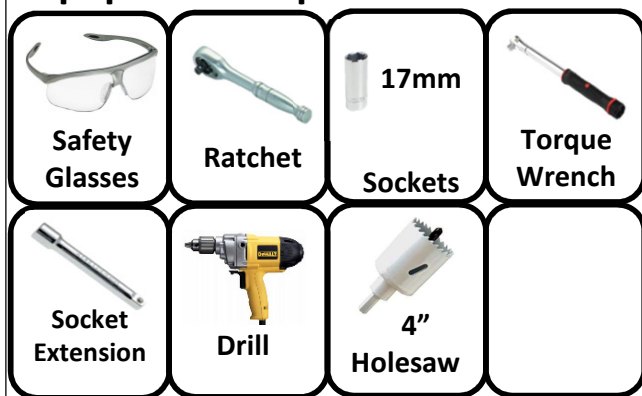

**DO NOT EXCEED LOWER OF TOWING VEHICLE  
MANUFACTURER'S RATING OR:**

**CARGO CAPACITY** – Do not exceed  
500 LB. (227 Kg) or Truck Front  
Gross Axle Weight Rating, (GAWR).

**9,000 lb.  
(4086 Kg)**

**MAXIMUM WINCH LINE PULL**

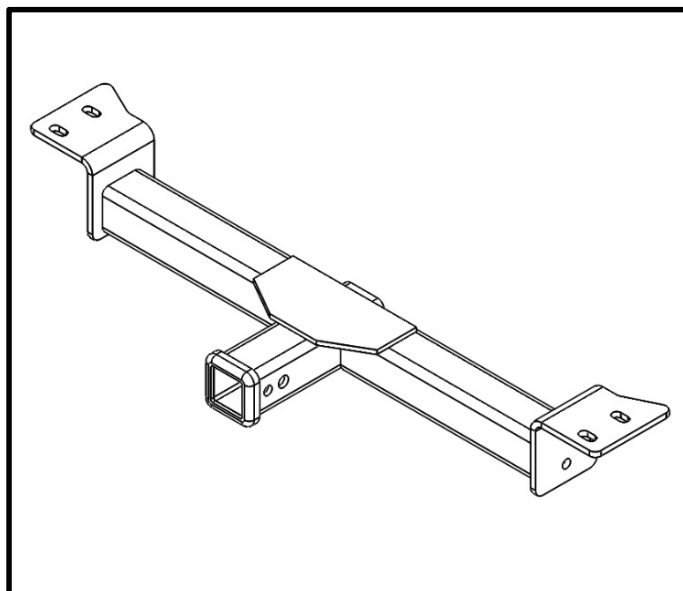



**Hitch Illustration**

**Always wear SAFETY GLASSES when installing hitch**

# Installation Instructions

## PART NUMBERS: 65080, CQT65080

Fastener Kit: 65080F		
①	Qty. (4)	Bolt M12x1.25x55mm Cl8.8 
②	Qty. (4)	Conical Tooth Washer 1/2" Part no. 01292008 

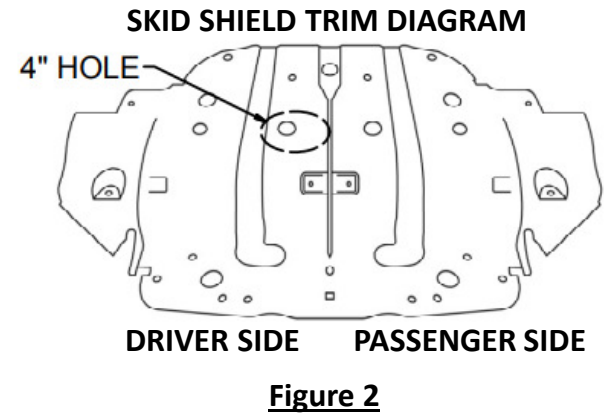
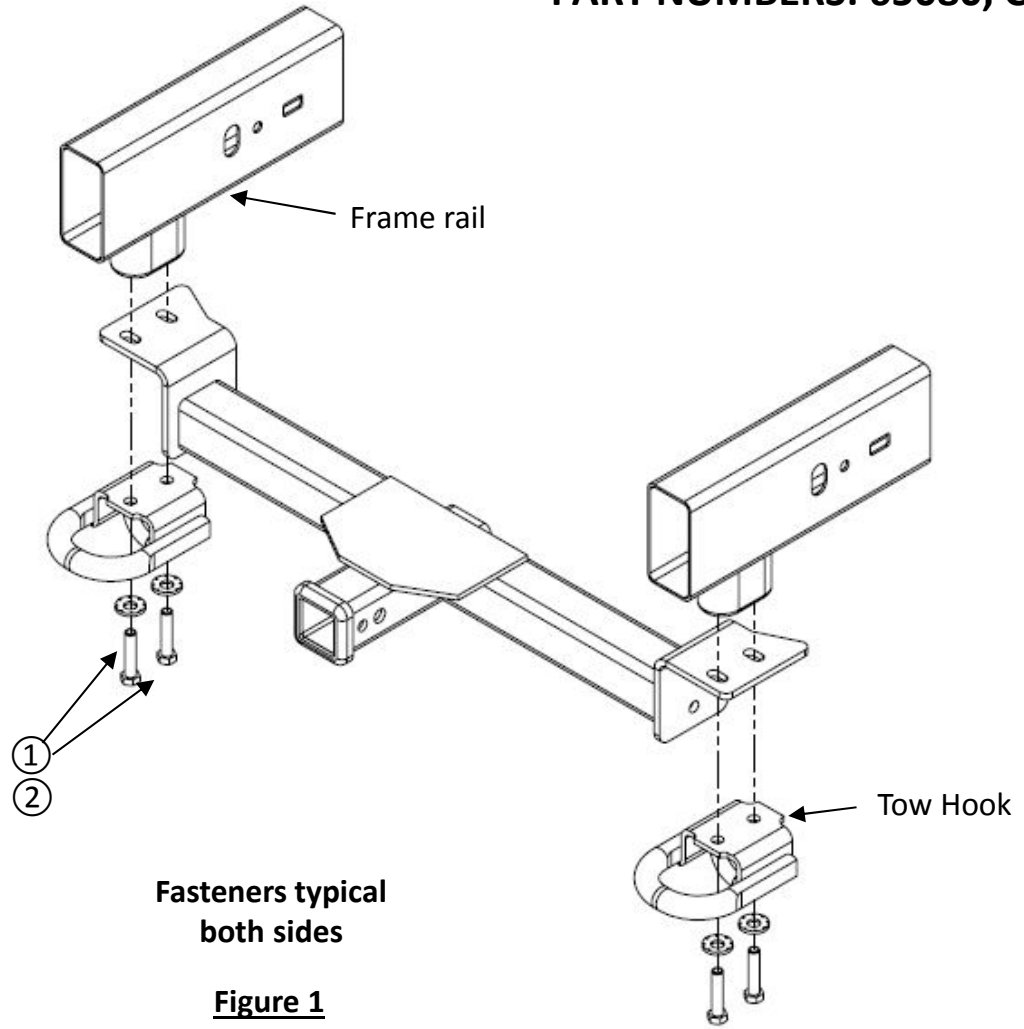

**NOTE:** If present, remove front skid shield and enlarge the hole shown in Figure 2 to allow for oil filter access. Reinstall trimmed skid shield.

- 1. Remove Tow Hooks**– Using a 17mm socket, remove (2) M12 bolts remove the tow hook and set aside for reinstallation later. Repeat for other side.
- 2. Raise hitch into position** – Install with tow hooks if present, install M12 bolts and conical washers (teeth side toward hitch) 2 each per side.
- 3. Torque M12 hardware to 42 ft\*lb (57 N\*M)**

**Proper torque is needed to keep the hitch secure to the vehicle when towing.**

Note: check hitch frequently, making sure all fasteners and ball are properly tightened. If hitch is removed, plug all holes in trunk pan or other body panels to prevent entry of water and exhaust fumes. A hitch or ball which has been damaged should be removed and replaced. Observe safety precautions when working beneath a vehicle and wear eye protection. Do not cut access or attachment holes with a torch.

This product complies with safety specifications and requirements for connecting devices and towing systems of the state of New York, V.E.S.C. Regulation V-5 and SAE J684.

When it comes to quality trailer hitches and towing, Draw-Tite is the brand you can depend on.