

# Installation Instructions

## PART NUMBERS: 65079, CQT65079

### Applications:

Years	Make	Models
2018-Current*	Jeep	Wrangler

### Installation Time: **35 min**

The time listed above is the average time for professional installers. If you do not feel comfortable performing this installation on your own or are in need of assistance, please contact a professional installer.



**Representative Vehicle Photo**

### Equipment Required:

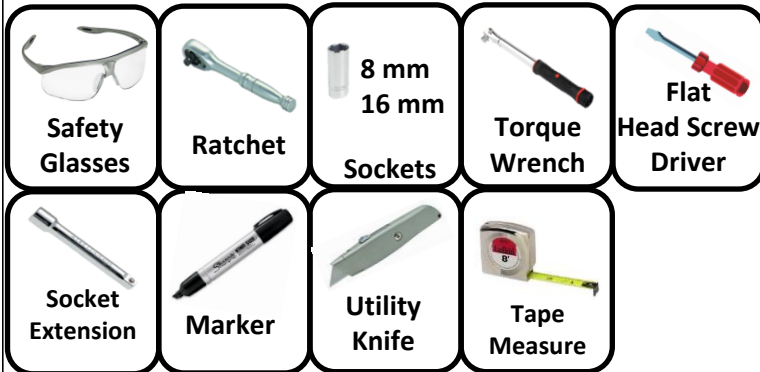

### DO NOT EXCEED LOWER OF TOWING VEHICLE MANUFACTURER'S RATING OR:

**CARGO CAPACITY** – Do not exceed  
500 LB. (227 Kg) or Truck **Front**  
Gross Axle Weight Rating, (GAWR).

**9,000 lb.**  
**(4086 Kg)**

**MAXIMUM WINCH LINE PULL**

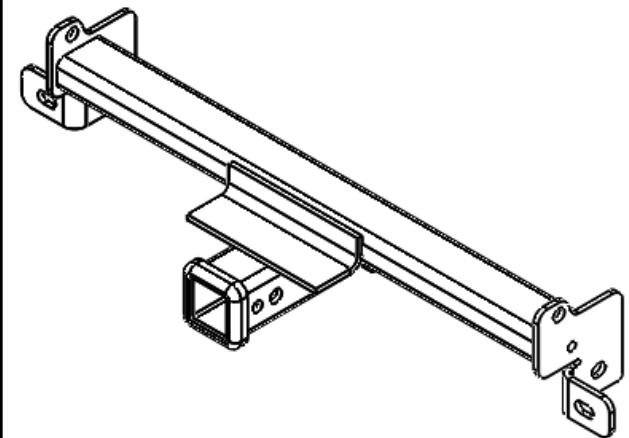







**Hitch Illustration**

**Always wear SAFETY GLASSES when installing hitch**

# Installation Instructions

## PART NUMBERS: 65079, CQT65079

### Fastener Kit: 65079F

①	Qty. (4)	Hex Bolt 1/2-13x1.75 Gr. 5	
②	Qty. (2)	Conical Tooth Washer 1/2" Part no. 01292008	
③	Qty. (2)	Lock washer 1/2"	
④	Qty. (2)	Conical Tooth Washer 7/16" Part no. 01292007	
⑤	Qty. (2)	Bolt M10 x 1.50 x 35 GR10.9	
⑥	Qty. (4)	Handle Nut 1/2" Part no. 1332	
⑦	Qty. (6)	Flat Washer 1/2"	

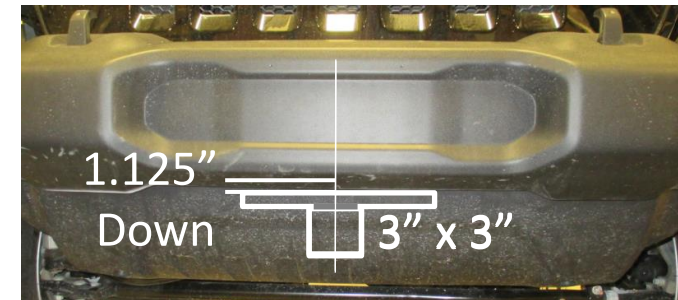
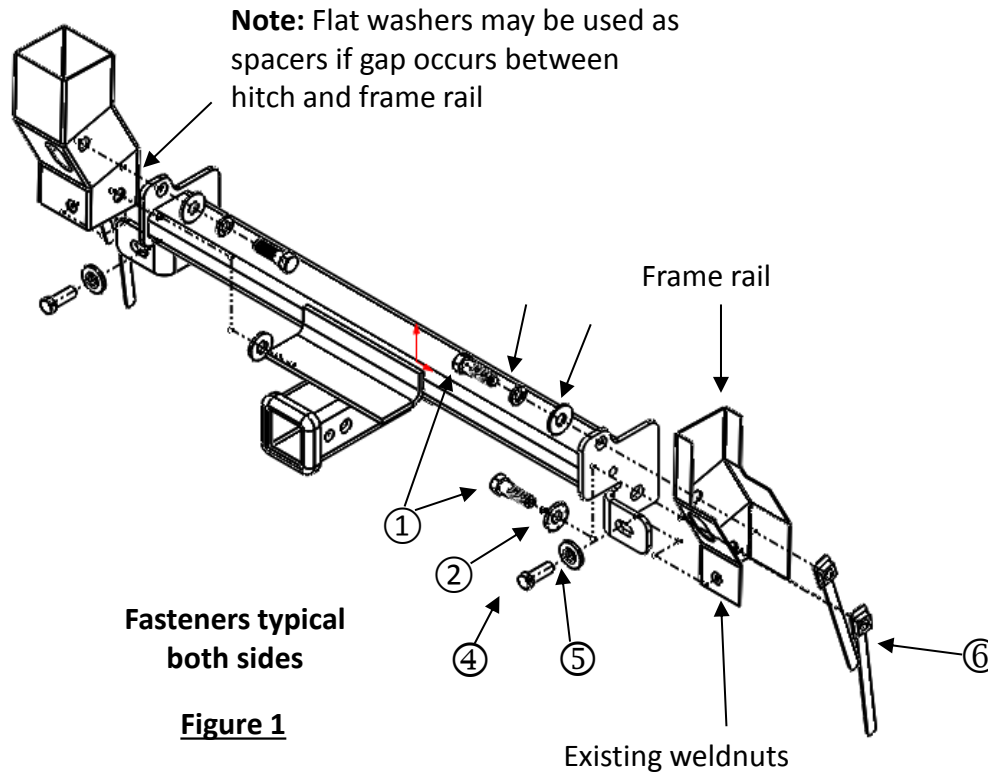

**Figure 2**

- Remove front plastic air dam** – Using a flat blade screwdriver, remove (8) push pins located on the forward side of the fascia. Using an 8mm socket, remove the (2) lower bolts. Remove the fascia and set aside.
- Remove front metal air dam** – Using a 16mm socket, remove the (2) 10mm bolts located on each side of the frame. Lift the air dam straight up and return to customer.
- Raise hitch into position**
- Install hardware** – install the (2) 10mm bolts and (2) 7/16" conical washers into the front face of the hitch, into the existing weldnuts inside the frame. Place (2) handle nuts inside the frame and align with the vertical attachment holes. Place (1) 1/2" bolt and (1) 1/2" conical washer into the lower hole on the hitch; place (1) 1/2" bolt and (1) 1/2" lock washer into the upper hole on the hitch.
- Torque all 1/2" hardware to 50 ft\*lb (68 N\*M) and all 10mm hardware to 38 ft\*lb. (52N\*M)**  
 **Proper torque is needed to keep the hitch secure to the vehicle when towing.**
- Trim the plastic air dam** according to figure 2
- Reinstall the plastic air dam by reversing step 1**

Note: check hitch frequently, making sure all fasteners and ball are properly tightened. If hitch is removed, plug all holes in trunk pan or other body panels to prevent entry of water and exhaust fumes. A hitch or ball which has been damaged should be removed and replaced. Observe safety precautions when working beneath a vehicle and wear eye protection. Do not cut access or attachment holes with a torch.

This product complies with safety specifications and requirements for connecting devices and towing systems of the state of New York, V.E.S.C. Regulation V-5 and SAE J684.

When it comes to quality trailer hitches and towing, Draw-Tite is the brand you can depend on.