

Installation Instructions

PART NUMBERS: 45508, 45708, CQT45297

Applications:

Years	Make	Models
99-16	Ford	F-250
99-16	Ford	F-350
08-15	Ford	F-450

Installation Time: **50 min**

The time listed above is the average time for professional installers. If you do not feel comfortable performing this installation on your own or are in need of assistance, please contact a professional installer.



Representative Vehicle Photo

Equipment Required:

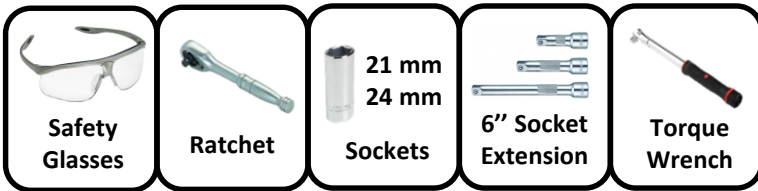

**DO NOT EXCEED LOWER OF TOWING VEHICLE
MANUFACTURER'S RATING OR:**

Hitch Type	Max Gross Trailer Weight	Max Tongue Weight
Weight Carrying	18,000 lb.(8172 kg)	2,000 lb. (908 kg)
Weight Distributing	18,000 lb.(8172 kg)	2,500 lb. (1135 kg)

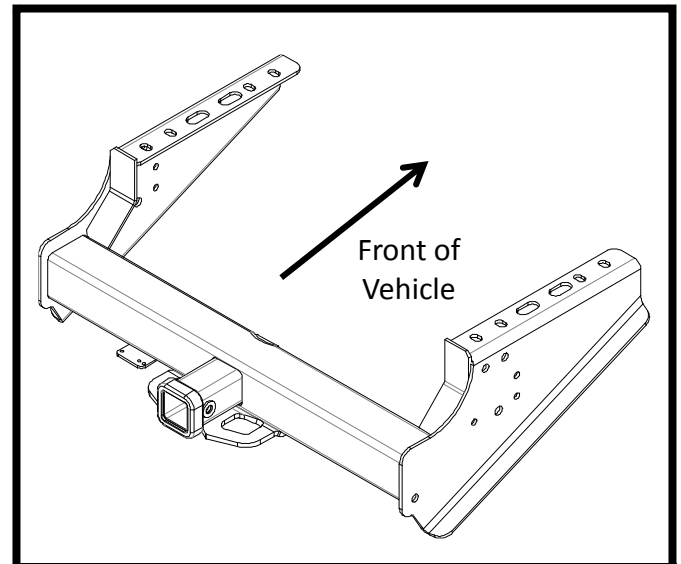

Hitch Illustration



Always wear SAFETY GLASSES when installing hitch

Installation Instructions

PART NUMBERS: 45508, 45708, CQT45297

Fastener Kit: 45508F

①	Qty. (12)*	Bolt M14 2.00x45mm, CL 10.9	
②	Qty. (24)	Conical washer 5/8"	
③	Qty. (12)*	Hex nut M14x2.00	
④	Qty. (4)	Spacer 1x2x3/16"	

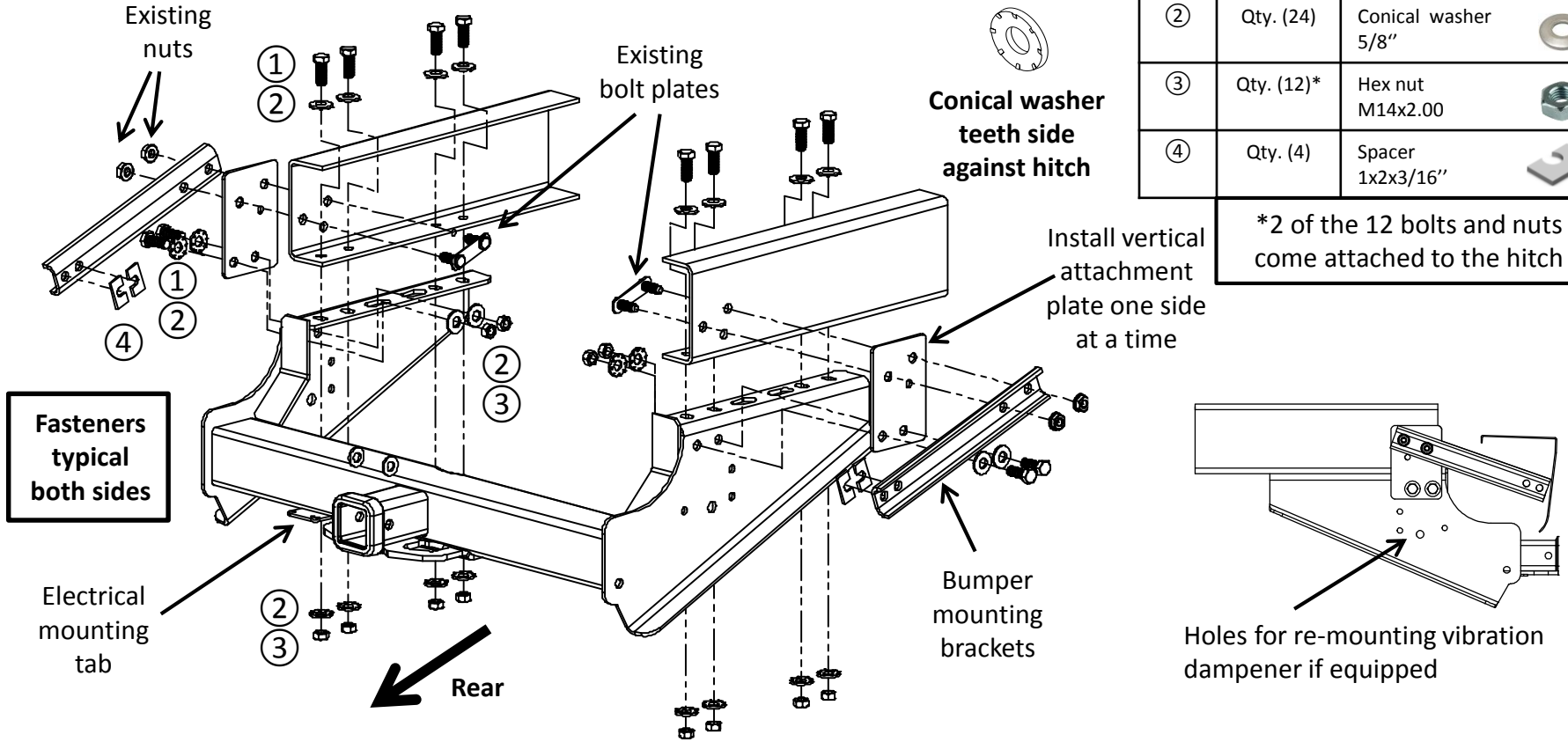

*2 of the 12 bolts and nuts come attached to the hitch

- Lower spare tire. Remove electrical plug mounting bracket, vibration dampener, and factory hitch if equipped. (large breaker bar may be required). Unbolt the plates from the hitch, save the plates, bolts and nuts for hitch installation.
- Insert the bolts and washers into the frame.
- Raise hitch into place and finger tighten washers and nuts.
- Working on one side at a time**, loosen the bolts from the bumper mounting bracket to the bumper enough to slide in the 3/16" spacers (item 4). adjust the bumper location before re-tightening of these bolts. repeat on other side
- Place a block of wood between new hitch and bumper to support bumper for next step.
- Working on one side at a time**, remove the nuts and bolt plates attaching the bumper mounting bracket to the frame. slide the vertical attachment between the two and re-install the factory hole plates and nuts. adjust the bumper location before re-tightening of these bolts. repeat on other side
- Using the hole pattern in the electrical mount tab, drill new holes in the factory electrical bracket and secure. fasteners not included.
- Tighten all M12 fasteners with torque wrench to 92 Lb.-Ft. (125 N*M) and all M14 fasteners to 115 Lb.-Ft. (156 N*M)**
- Raise spare tire.



Proper torque is needed to keep the hitch secure to the vehicle when towing.

Note: check hitch frequently, making sure all fasteners and ball are properly tightened. If hitch is removed, plug all holes in trunk pan or other body panels to prevent entry of water and exhaust fumes. A hitch or ball which has been damaged should be removed and replaced. Observe safety precautions when working beneath a vehicle and wear eye protection. Do not cut access or attachment holes with a torch.

This product complies with safety specifications and requirements for connecting devices and towing systems of the state of New York, V.E.S.C. Regulation V-5 and SAE J684.

When it comes to quality trailer hitches and towing, Draw-Tite is the brand you can depend on.