



Installation Instructions

PART NUMBERS: 36798, 06181,
CQT36798

Applications:

Years	Make	Models
2017-Current*	Chrysler	Pacifica





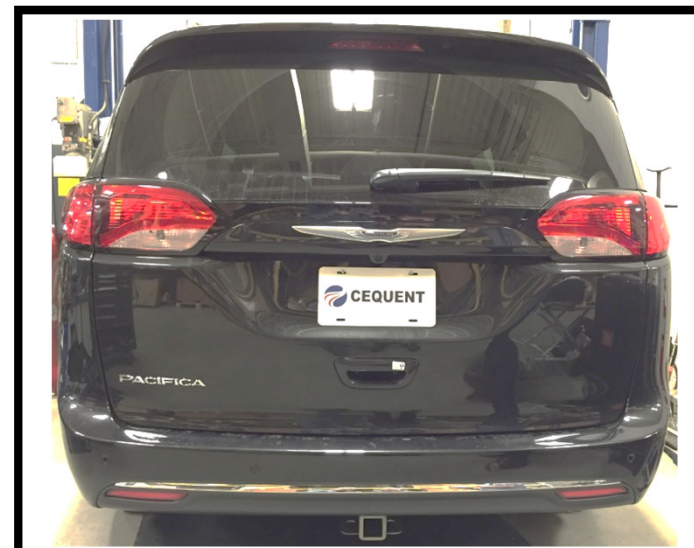



Installation Time: 45 min.

The time listed above is the average time for professional installers. If you do not feel comfortable performing this installation on your own or are in need of assistance, please contact a professional installer.



Representative Vehicle Photo

Equipment Required:

 Safety Glasses	 Ratchet	 7/8" 8mm 10mm Sockets	 Torque Wrench
 Exhaust Removal Pliers	 Flat Head Screw Driver	 6" Socket Extension	 Tin Snips

Hybrid Models require service kit 76046SK (Sold separately)

DO NOT EXCEED LOWER OF TOWING VEHICLE MANUFACTURER'S RATING OR:

Hitch Type	Max Gross Trailer Weight	Max Tongue Weight
Weight Carrying	3500 lb. (1589 kg)	300 lb. (136 kg)
Weight Distributing	N/A	N/A

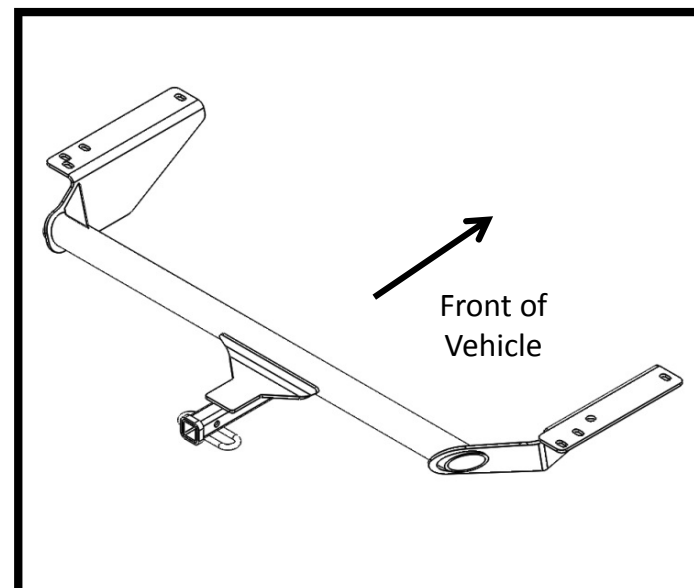

Hitch Illustration

Always wear SAFETY GLASSES when installing hitch

Installation Instructions

PART NUMBERS: 36798, 06181, CQT36798

Fastener Kit: 36798F

Figure 4

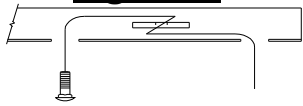

Kink pullwire to keep spacer independent of bolt

Figure 5

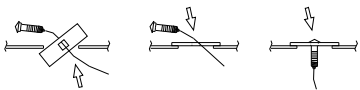

A. Insert bolt and Block into frame
B. Align block on access hole
C. Pull bolt thru block

Figure 2

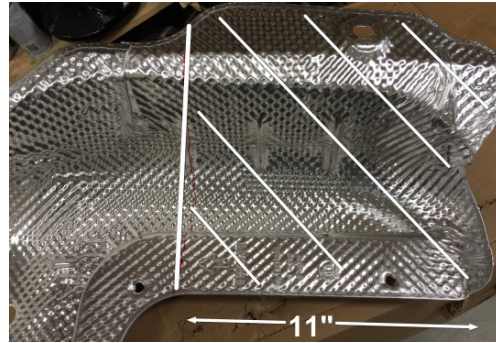

Hybrid Models require service kit 76046SK

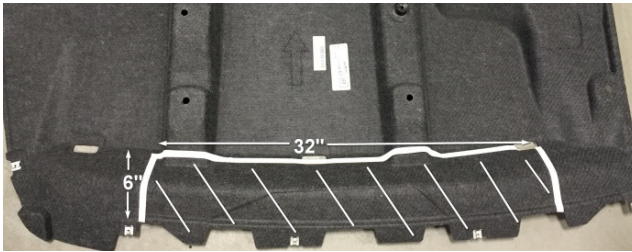
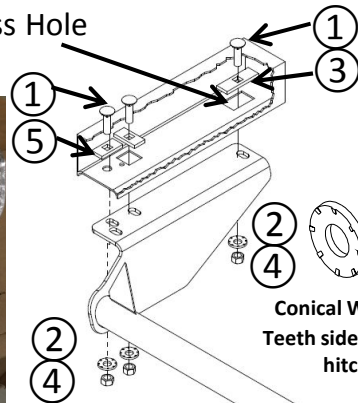

Figure 3

Access Hole



Conical Washer
Teeth side against hitch

Frame Rail

Authorized Drawbar Kit: 36071 (Sold Separately)
Drawbar must be used in the **RISE** position only.

Figure 1

Fastener Kit: 36798F			
①	Qty. (6)	Carriage Bolt ½"-13 x 1.75 Gr5	
②	Qty. (6)	Conical washer 1/2"	
③	Qty. (2)	Block 1/4" x 1" x 3"	
④	Qty. (6)	Hex Nut ½"-13 Gr5	
⑤	Qty. (4)	Block 1/4" x 1" x 2"	
⑥	Qty. (6)	Pull wire ½"	

- Remove Underbody Panel** – Remove (9) M8 fasteners and (5) M10 nuts and (2) plastic push-on fasteners (unscrew with standard screwdriver while pulling down on panel). Set the panel aside.
- Lower exhaust** – Pry off (2) rearmost rubber exhaust hangers using exhaust removal pliers or other suitable tool (spray with soapy water to make this easier). Be sure to support exhaust system to prevent damage.
- Remove Heat Shield** – Remove the (2) remaining M10 nuts (one nut is above the muffler). Set the heat shield aside.
- Fishwire rearward bolts** - Using the fishwire method (Figure 4) install the carriage bolts and 2" long blocks through the access hole and into the rearward attachment holes, be careful the blocks are not overlapping each other, leave pullwires attached.
- Fishwire forward bolts** - Using the reverse fishwire method (Figure 5) install the carriage bolts and 3" long blocks into the forward attachment holes, leave pullwires attached.
- Install hitch** - Raise hitch into position, passenger side first over the muffler, guide the fishwire ends through the attachment holes, remove pullwire and install the conical washers (teeth side toward hitch) and ½" hex nuts onto the carriage bolts. Assure no wires or other items have been pinched between hitch and vehicle frame.
- Tighten all hitch fasteners with torque wrench to 75 Lb.-Ft. (102 N*M)**

Proper torque is needed to keep the hitch secure to the vehicle when towing.

- Trim heat shield** – Trim heat shield according to Figure 2. Reinstall remaining portion of heat shield
- Reinstall exhaust hangers** – Raise exhaust back into position and reinstall all exhaust hangers.
- Trim underbody panel** - Trim underbody panel according to Figure 3. Reinstall underbody panel.

Note: check hitch frequently, making sure all fasteners and ball are properly tightened. If hitch is removed, plug all holes in trunk pan or other body panels to prevent entry of water and exhaust fumes. A hitch or ball which has been damaged should be removed and replaced. Observe safety precautions when working beneath a vehicle and wear eye protection. Do not cut access or attachment holes with a torch.

This product complies with safety specifications and requirements for connecting devices and towing systems of the state of New York, V.E.S.C. Regulation V-5 and SAE J684.

1. Remove Underbody Panel – Remove (9) M8 fasteners and (5) M10 nuts and (2) plastic push-on fasteners (unscrew with standard screwdriver while pulling down on panel). Set the panel aside.



2. Lower exhaust – Pry off (2) rearmost rubber exhaust hangers using exhaust removal pliers or other suitable tool (spray with soapy water to make this easier). Be sure to support exhaust system to prevent damage.

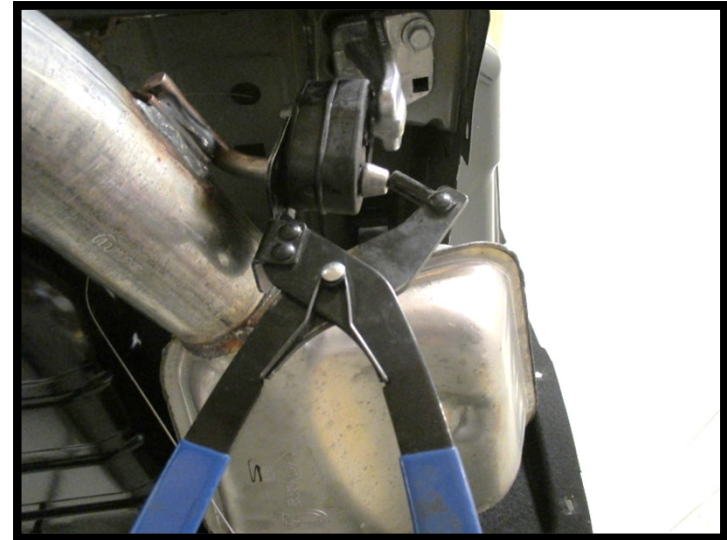

3. Remove Heat Shield – Remove the (2) remaining M10 nuts (one nut is above the muffler). Set the heat shield aside.

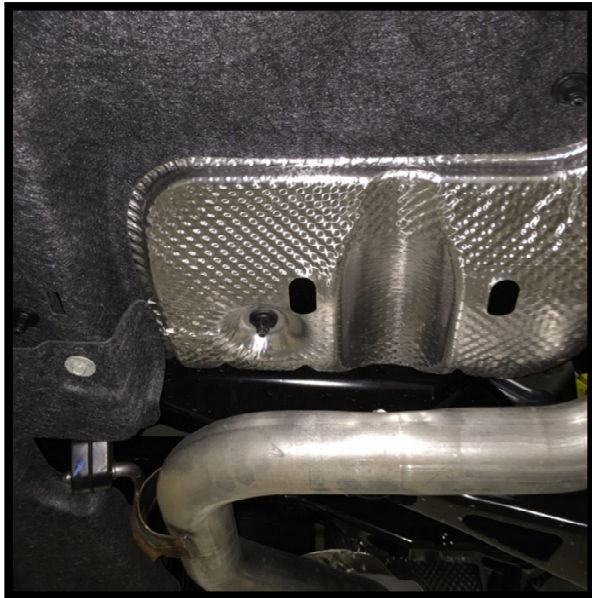

4. Fishwire rearward bolts - Using the fishwire method (Figure 4) install the carriage bolts and 2" long blocks through the access hole and into the rearward attachment holes, be careful the blocks are not overlapping each other, leave pullwires attached.



5. Fishwire forward bolts - Using the reverse fishwire method (Figure 5) install the carriage bolts and 3" long blocks into the forward attachment holes, leave pullwires attached.

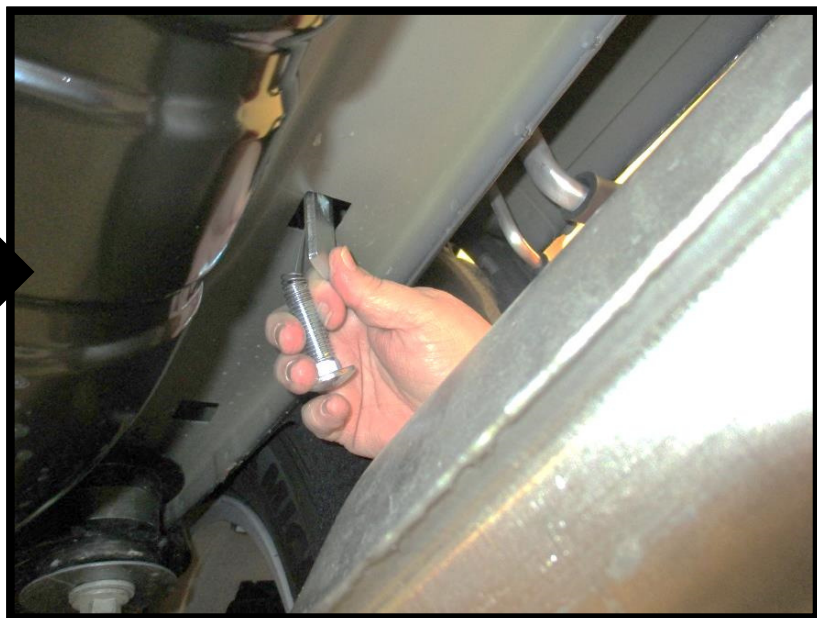

6. Install hitch - Raise hitch into position, passenger side first over the muffler, guide the fishwire ends through the attachment holes, remove pullwire and install the conical washers (teeth side toward hitch) and 1/2" hex nuts onto the carriage bolts. Assure no wires or other items have been pinched between hitch and vehicle frame.



7. Tighten all hitch fasteners with torque wrench to 75 lb.-ft. (102 N*M)

⚠ Proper torque is needed to keep the hitch secure to the vehicle when towing.



8. Trim heat shield - Trim heat shield according to Figure 2. Reinstall remaining portion of heat shield

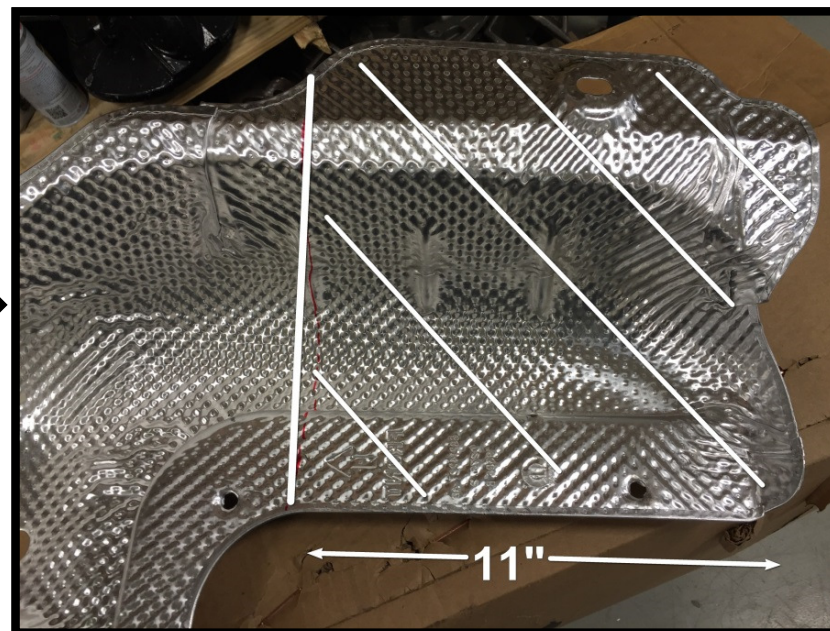

9. Reinstall exhaust hangers – Raise exhaust back into position and reinstall all exhaust hangers.

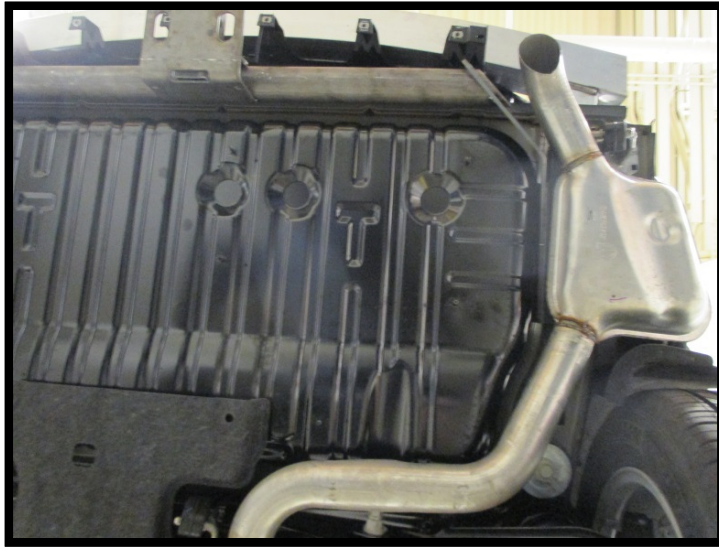

10. Trim underbody panel - Trim underbody panel according to Figure 3. Reinstall underbody panel.

