



Installation Instructions

PART NUMBERS: 36642, 06180, CQT36642

Applications:

Years	Make	Models
2018-Current*	Chevrolet	Equinox
2018-Current*	GMC	Terrain





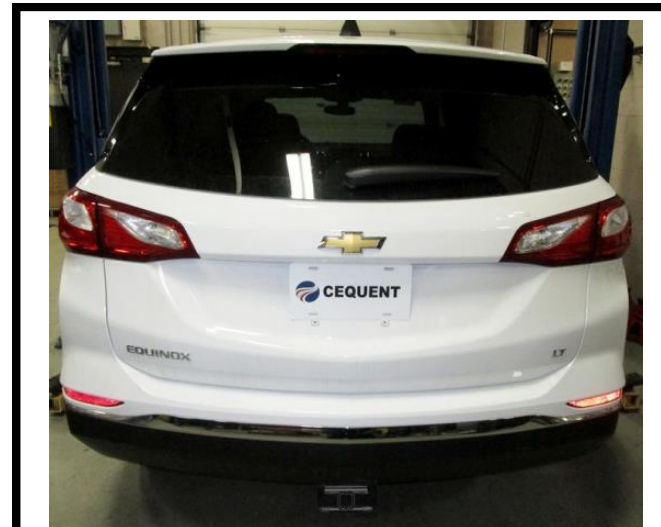

Installation Time: 35 min

The time listed above is the average time for professional installers. If you do not feel comfortable performing this installation on your own or are in need of assistance, please contact a professional installer.



Representative Vehicle Photo

Equipment Required:

 Safety Glasses	 Ratchet	 15 mm 11/16 Socket	 Torque Wrench	 6" Socket Extension
 Exhaust Removal Pliers	 T15 Torxbit Socket			

DO NOT EXCEED LOWER OF TOWING VEHICLE MANUFACTURER'S RATING OR:

Hitch Type	Max Gross Trailer Weight	Max Tongue Weight
Weight Carrying	3500 lb. (1589 kg)	350 lb. (159 kg)
Weight Distributing	N/A	N/A

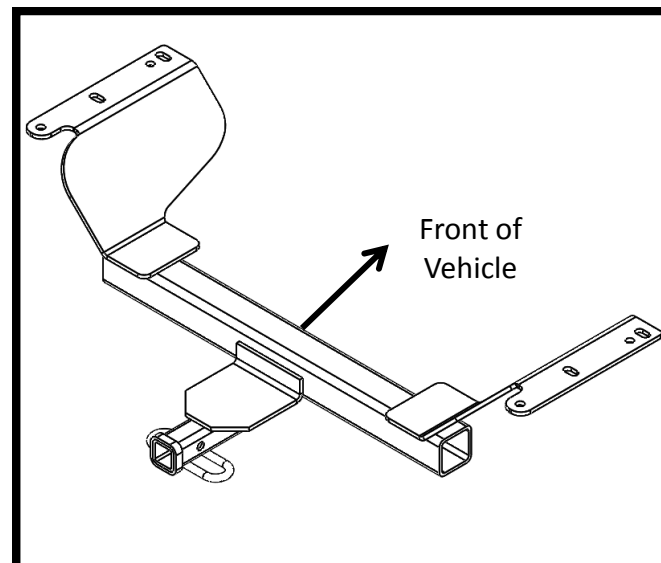

Hitch Illustration



Always wear SAFETY GLASSES when installing hitch

Installation Instructions

PART NUMBERS: 36642, 06180, CQT36642

Fastener Kit: 76419F





①	Qty. (6)	Carriage Bolt 7/16-14 x 1.5 GR5	
②	Qty. (6)	Block 1/4 x 7/8 x 3 Part# HE-2370-000	
③	Qty. (6)	Conical Tooth Washer 7/16 Part# 01292007	
④	Qty. (6)	Hex Nut 7/16-14	
⑤	Qty. (6)	Pullwire 7/16 Part# 5481	

Figure 2



Kink pullwire to keep spacer independent of bolt

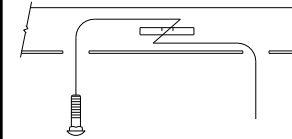
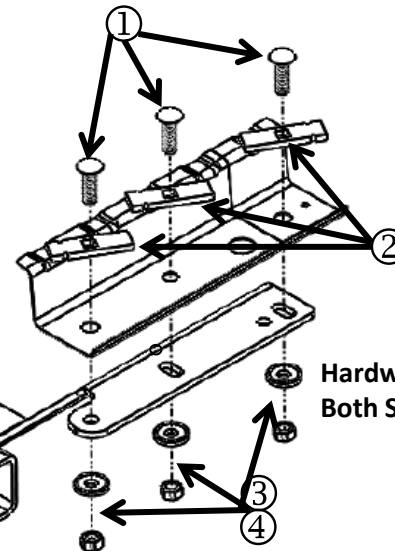
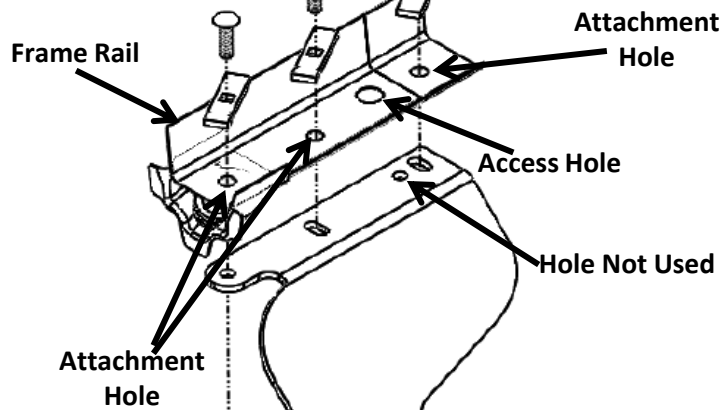

Hardware Typical Both Sides

Authorized Drawbar Kit:
36061 (Sold Separately)
Drawbar must be used in the **RISE** position only.

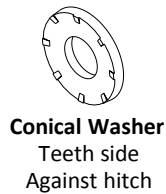

Figure 1

- Lower Muffler - NOTE:** A spray of lubricant on rubber hangers makes them slide off metal pins more easily. **NOTE:** Be careful that exhaust is supported before removing rubber hangers.
 - Remove the (2) screws from the bottom of the rear fascia using a T15 torxbit.
 - Remove the bolts (2 per bracket) from the rear exhaust hanger brackets using a 15mm socket. Then remove the bracket from the hanger tabs.
 - Remove the rubber isolator from hanger in front of the muffler.
 - Lower the exhaust (1) side at a time by pulling on the rear fascia.**NOTE:** Pull the wire harness off the passenger side frame if extra clearance is needed. Reinstall after the hitch is in place.
- Install Hardware -** Feed coiled end of pull wire through an attachment hole in the frame and out of the access hole, attach items 1 and 2 and pull the hardware into place. (3 per side) (See figure1 and 2) **Note:** Leaving the pull wire attached until the hitch is raised into place will help from pushing the hardware back into the frame.
- Raise Hitch-** Raise the hitch into place being careful not to push the hardware into the frame. Loosely install items 3 and 4.
- Raise Muffler-** Raise the muffler back into place by reversing the steps completed in step 1.
- Torque Hardware-** Torque all 7/16-14 Gr5 hardware to 50ft-lb (68n-m) **⚠ Proper torque is needed to keep the hitch secure to the vehicle when towing.**

Note: check hitch frequently, making sure all fasteners and ball are properly tightened. If hitch is removed, plug all holes in trunk pan or other body panels to prevent entry of water and exhaust fumes. A hitch or ball which has been damaged should be removed and replaced. Observe safety precautions when working beneath a vehicle and wear eye protection. Do not cut access or attachment holes with a torch.

This product complies with safety specifications and requirements for connecting devices and towing systems of the state of New York, V.E.S.C. Regulation V-5 and SAE J684.

1. **Lower Muffler - NOTE:** A spray of lubricant on rubber hangers makes them slide off metal pins more easily.

a) Remove the (2) screws from the bottom of the rear fascia using a T15 torxbit.



1. **b) Remove the bolts (2 per bracket) from the rear exhaust hanger brackets using a 15mm socket. Then remove the bracket from the hanger tabs.**

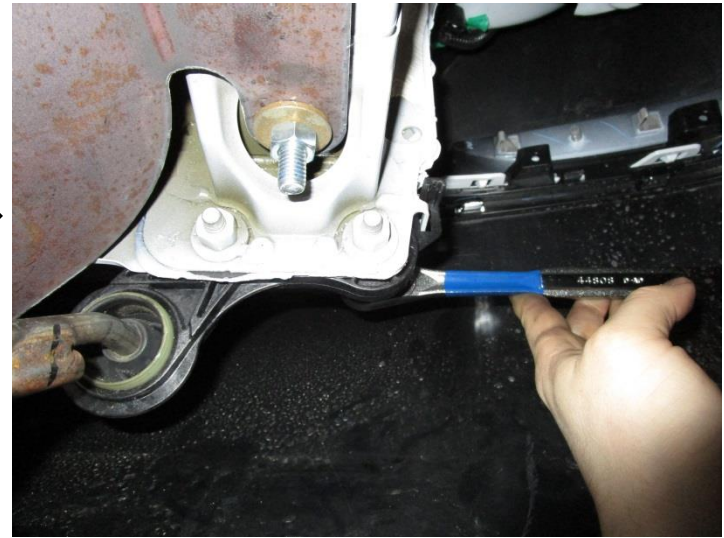

1. **NOTE:** Be careful that exhaust is supported before removing rubber hangers.

c) Remove the rubber isolator from hanger in front of the muffler.



1. **d) Lower the exhaust (1) side at a time by pulling on the rear fascia.**



NOTE: Pull the wire harness off the passenger side frame if extra clearance is needed. Reinstall after the hitch is in place.



2. **Install Hardware** - Feed coiled end of pull wire through an attachment hole in the frame and out of the access hole, attach items 1 and 2 and pull the hardware into place. (3 per side) (See figure 1 and 2) **Note:** Leaving the fish wire attached until the hitch is raised into place will help from pushing the hardware back into the frame.



3. **Raise Hitch**- Raise the hitch into place being careful not to push the hardware into the frame.

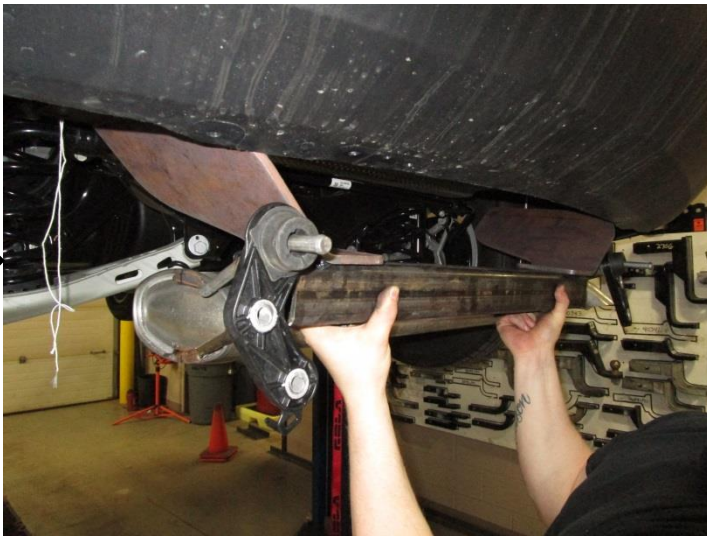

3. **Raise Hitch**- Loosely install items 3 and 4.



4. **Raise Muffler-** Raise the muffler back into place by reversing the steps completed in step 1.



NOTE:



5. **Torque Hardware-** Torque all 7/16-14 Gr5 hardware to 50ft-lb (68n-m)



Proper torque is needed to keep the hitch secure to the vehicle when towing.

