



Installation Instructions

PART NUMBERS: 36601, 06185, CQT36601

Applications:

| Years | Make | Models |
|---------------|-------|--------|
| 2013-Current* | Mazda | CX-5 |

Installation Time: 20 Min.

The time listed above is the average time for professional installers. If you do not feel comfortable performing this installation on your own or are in need of assistance, please contact a professional installer.



Representative Vehicle Photo

Equipment Required:

| | | | | | |
|----------------|---------------|--|--------------------------------------|--------------------------------|---------------------------|
| Safety Glasses | Ratchet | 6" socket Extension | Exhaust Removal Pliers | Pry Bar | Lubricant or Soapy water |
| 3 / 4 " | Torque Wrench | * Optional Small Flat Head Screw Driver | * Optional Universal Joint Socket | * Optional Ratchet tie down | * Optional Bungee cord |

DO NOT EXCEED LOWER OF TOWING VEHICLE MANUFACTURER'S RATING OR:

| Hitch Type | Max Gross Trailer Weight | Max Tongue Weight |
|---------------------|--------------------------|-------------------|
| Weight Carrying | 3500 lb. (1589 kg) | 350 lb. (159 kg) |
| Weight Distributing | --- | --- |

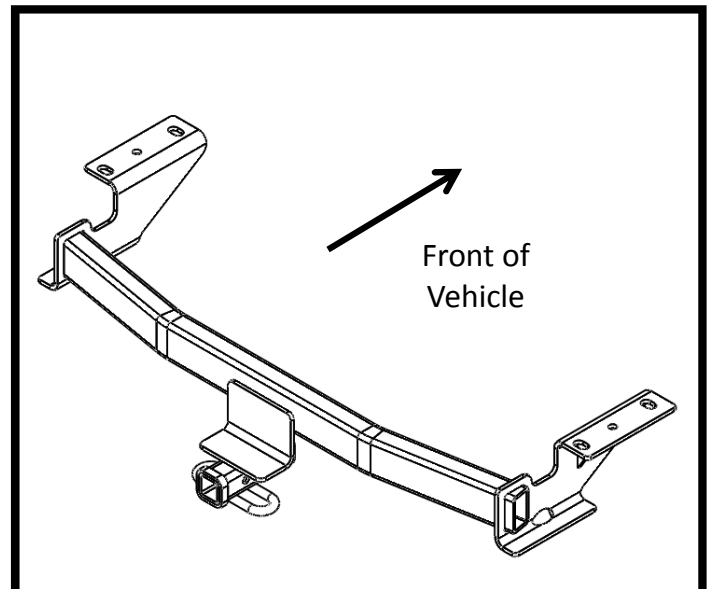

Hitch Illustration

Always wear SAFETY GLASSES when installing hitch





Installation Instructions

PART NUMBERS: 36601, 06185, CQT36601

Authorized Drawbar Kit: 36051 (Sold Separately)

Drawbar must be used in the **RISE** position only

FASTENERS TYPICAL ON BOTH SIDES

| Fastener Kit : 36601F | | |
|-----------------------|---------------------|--|
| ① | Qty. (4) | Carriage bolt ½-13 x 1.50 GR5  |
| ② | Qty. (4) (3022) | Spacer .250 x 1 x3  |
| ③ | Qty. (4) (02192008) | Conical washer ½"  |
| ④ | Qty. (4) | Hex Nut ½ -13 GR5  |
| ⑤ | Qty. (4) | Fish wire ½-13  |

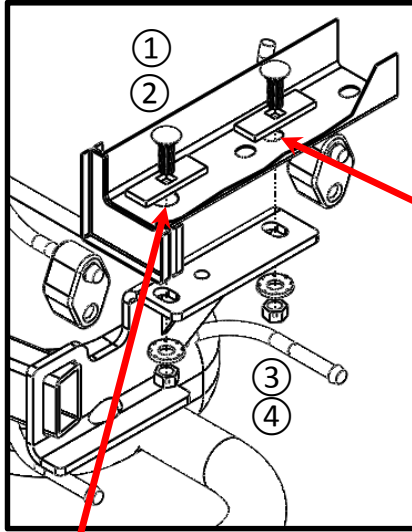
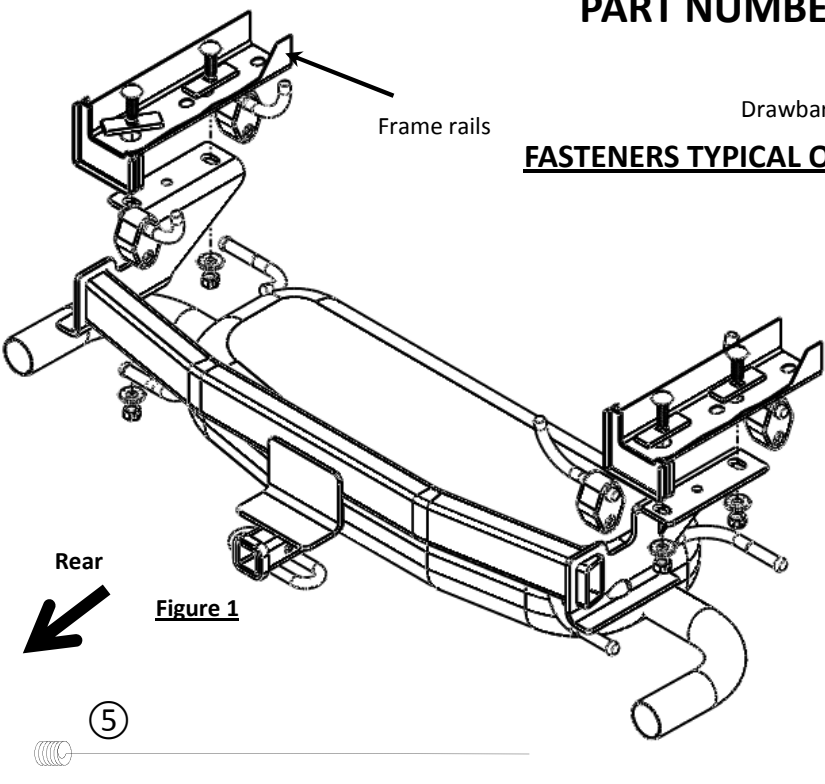

Forward attachment hole

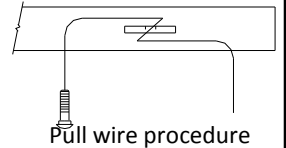

Figure 2



Reverse pull wire procedure

Figure 3

- Support and lower exhaust:** Lower the exhaust by removing (4) rubber hangers, and support the exhaust to prevent it from falling under it's own weight. Spraying a lubricant or soapy water on the metal hanger rod and the rubber isolator helps removal.
 - Remove plastic rivets:** If present remove the plastic rivets that fasten the fascia tabs to the vehicle. Note: Remove the center of the rivet with a flat screwdriver. Keep for re-installation.
 - Install fasteners:** Feed the coiled end of the pull wire ⑤ through the forward attachment hole in the frame and out the access hole. Feed spacer ② onto the pull wire ⑤ and thread the carriage bolt ① onto the pull wire ⑤. Pull the pull wire ⑤ with fasteners into location through the hole. Leave pull wire ⑤ attached. Repeat the same process on the both frame rails. See figure 2. Using the reverse pull wire procedure thread carriage bolt ① onto the pull wire ⑤ and feed it into the access hole on the frame rail then feed the spacer ② onto the pull wire ⑤ and feed it into the access hole and pull the carriage bolt ① into position through the spacer. Leave the pull wire ⑤ attached. See figure 3.
 - Install hitch:** Raise the hitch above exhaust, feed pull wires ⑤ through the attachment points on hitch brackets. (Gently pull fascia rearward as needed to gain access between the fascia and exhaust hanger.)
 - Install fastener:** Using the conical washer ③ to hold the bolt in place remove the pull wires ⑤ and attach the hex nut ④. Hand tighten both sides.
 - Tighten all 1/2 GR5 fasteners to 75 lb.-ft. (102 N*M)** Note : A universal joint socket may be needed to tighten the rearward fasteners on both sides.
- ⚠ Proper torque is needed to keep the hitch secure to the vehicle when towing.**
- Reinstall exhaust:** Raise the exhaust back into position and remove the exhaust support. Spraying a lubricant or soapy water on the metal hanger rod and the rubber isolator helps with reinstalling.
 - Reinstall plastic rivets if removed in step 2.

Note: check hitch frequently, making sure all fasteners and ball are properly tightened. If hitch is removed, plug all holes in trunk pan or other body panels to prevent entry of water and exhaust fumes. A hitch or ball which has been damaged should be removed and replaced. Observe safety precautions when working beneath a vehicle and wear eye protection. Do not cut access or attachment holes with a torch.

This product complies with safety specifications and requirements for connecting devices and towing systems of the state of New York, V.E.S.C. Regulation V-5 and SAE J684.

1. Support and lower exhaust: Lower the exhaust by removing (4) rubber hangers, and support the exhaust to prevent it from falling under its own weight. Spraying a lubricant or soapy water on the metal hanger rod and the rubber isolator helps removal.



2. Remove plastic rivets: If present remove the plastic rivets that fasten the fascia tabs to the vehicle. Note: Remove the center of the rivet with a flat screwdriver. Keep for re-installation.

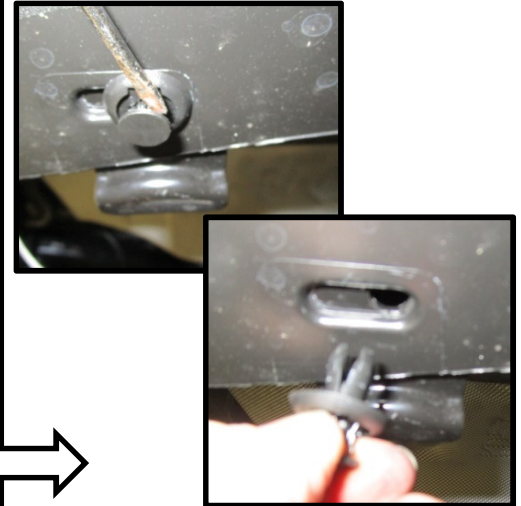

3. Install fasteners: Feed the coiled end of the pull wire ⑤ through the forward attachment hole in the frame and out the access hole. Feed spacer ② onto the pull wire ⑤ and thread the carriage bolt ① onto the pull wire ⑤. Pull the pull wire ⑤ with fasteners into location through the hole. Leave pull wire ⑤ attached. Repeat the same process on the both frame rails. See figure 2. Using the reverse pull wire procedure thread carriage bolt ① onto the pull wire ⑤ and feed it into the access hole on the frame rail then feed the spacer ② onto the pull wire ⑤ and feed it into the access hole and pull the carriage bolt ① into position through the spacer. Leave the pull wire ⑤ attached. See figure 3.



4. Install hitch: Raise the hitch above exhaust, feed pull wires ⑤ through the attachment points on hitch brackets. (Gently pull fascia rearward as needed to gain access between the fascia and exhaust hanger.)

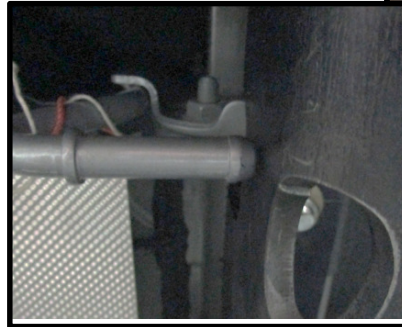

5. Install fastener: Using the conical washer ③ to hold the bolt in place remove the pull wires ⑤ and attach the hex nut ④. Hand tighten both sides.



6. Tighten all 1/2 GR5 fasteners to 75 lb-ft. (102 N*M) Note : A universal joint socket may be needed to tighten the rearward fasteners on both sides.

⚠ Proper torque is needed to keep the hitch secure to the vehicle when towing.



7. **Reinstall exhaust:** Raise the exhaust back into position and remove the exhaust support. Spraying a lubricant or soapy water on the metal hanger rod and the rubber isolator helps with reinstalling.

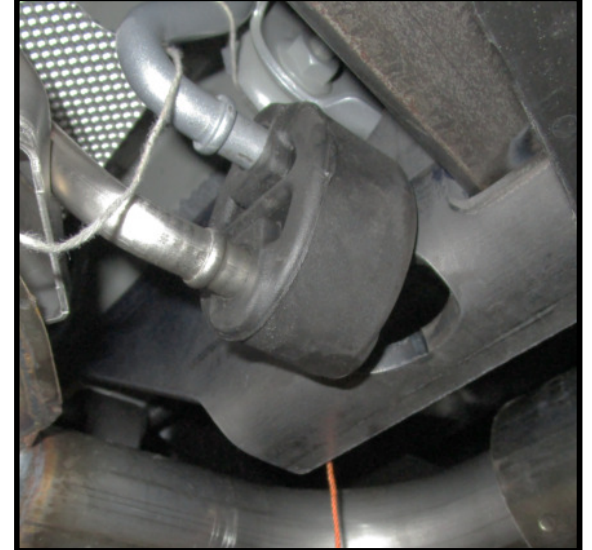
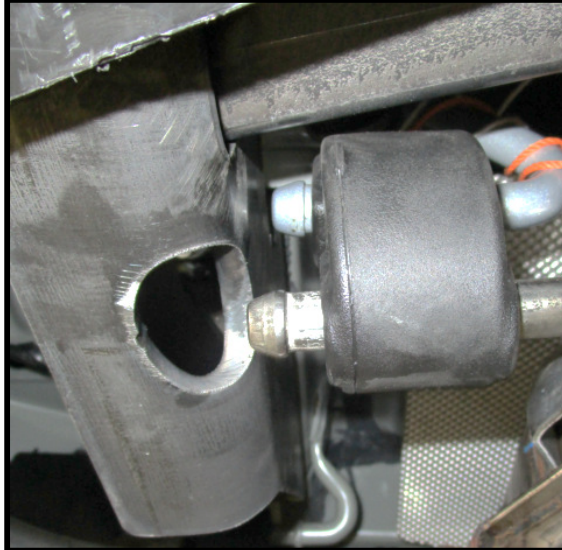

8. Reinstall plastic rivets if removed in step 2.

