

Installation Instructions

PART NUMBERS: 36597, 06183, CQT36597

Applications:

| Years | Make | Models |
|---------------|-------|--------|
| 2017-Current* | Honda | CR-V |







Installation Time: 20 min.

The time listed above is the average time for professional installers. If you do not feel comfortable performing this installation on your own or are in need of assistance, please contact a professional installer.

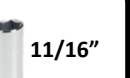

Representative Vehicle Photo

Equipment Required:

| | | | |
|----------------------------------------------------------------------------------------------------------|-------------------------------------------------------------------------------------------------------------|--------------------------------------------------------------------------------------------------------|----------------------------------------------------------------------------------------------------|
|  Safety Glasses |  Ratchet |  11/16" Sockets |  Torque Wrench |
|  6" Socket Extension |  Exhaust Removal Pliers | | |

**DO NOT EXCEED LOWER OF TOWING VEHICLE
MANUFACTURER'S RATING OR:**

| Hitch Type | Max Gross Trailer Weight | Max Tongue Weight |
|---------------------|--------------------------|-------------------|
| Weight Carrying | 3500 lb. (1589 Kg) | 350 lb. (159 kg) |
| Weight Distributing | N/A | N/A |

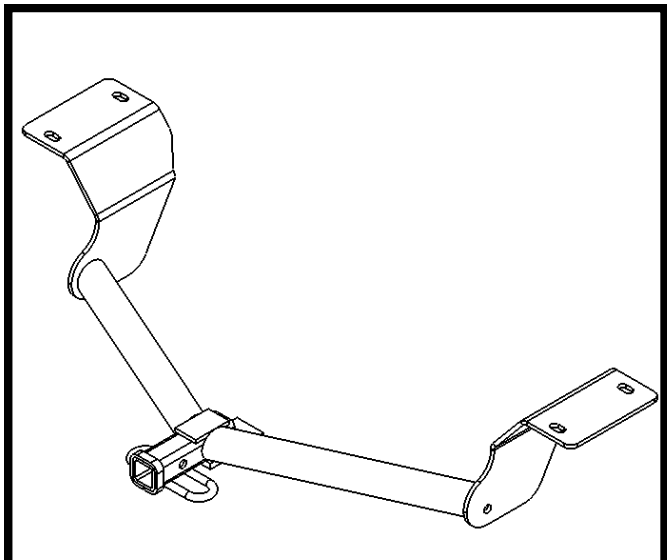

Hitch Illustration

Always wear SAFETY GLASSES when installing hitch

Installation Instructions

PART NUMBERS: 36597, 06183, CQT36597

Fasteners typical for both sides

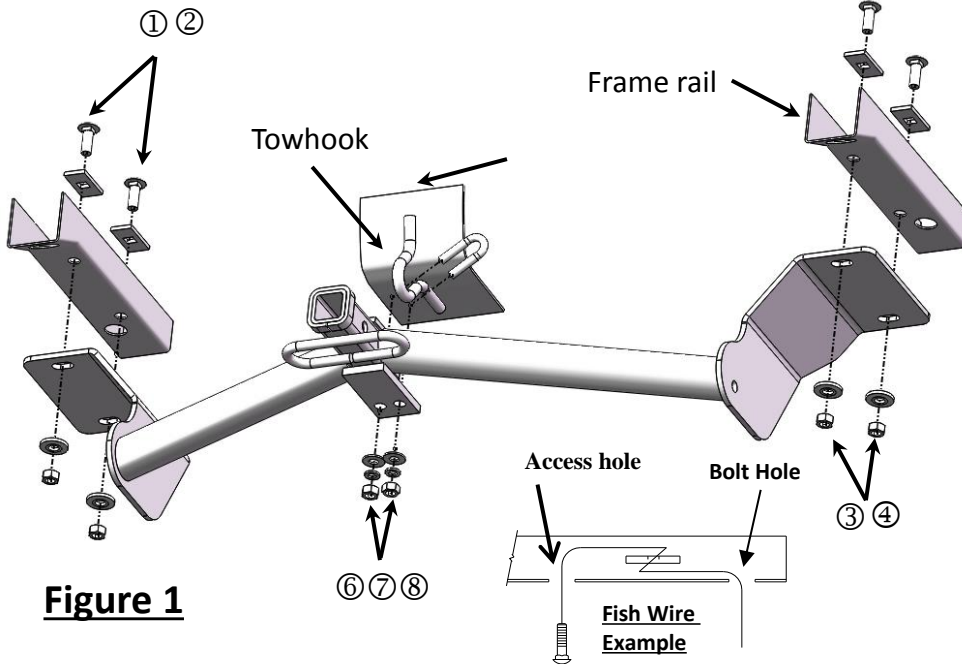







Figure 2



| Fastener Kit: 36597F | | |
|----------------------|----------|------------------------------------------------------------------------------------------------------------------------|
| ① | Qty.(4) | Carr. Bolt 7/16"-14 X 1 1/4" GR5  |
| ② | Qty.(4) | Spacer 3/16" x 1" x 2"  |
| ③ | Qty.(4) | Conical washer 7/16"  |
| ④ | Qty.(4) | Hex Nut 7/16"-14 GR2  |
| ⑤ | Qty.(1) | U Bolt 3/8"-16 GR5  |
| ⑥ | Qty. (2) | Flat washer 3/8"  |
| ⑦ | Qty. (1) | Lock washer 3/8"  |
| ⑧ | Qty. (1) | Hex Nut 3/8"-16 GR2  |
| ⑨ | Qty. (4) | Fish wire 7/16"  |

**Authorized Drawbar Kit:
36051 (Sold Separately)**
Drawbar must be used in the **RISE** position only.

- Lower exhaust** - Remove the rubber isolators from the exhaust at the rear of the vehicle, (figure 2) both sides. It may be necessary to remove the isolator forward of the rear axle. Spraying a lubricant or soapy water on the metal hanger rod and the rubber isolator eases removal.
- Install hardware** - Using the fish wire install items 1 and 2 as shown in figure 1 through the large access hole at the end of the vehicle frame. Repeat for both sides. **Note:** Keep the fish wire attached to the hardware.
- Install hitch** - Gently raise hitch into position, carefully guiding the hitch over the mufflers. Feed the end of the fish wires through the attachment holes in the hitch, be careful not to push the hardware back into the vehicle frame. Loosely install items 3 and 4 to hold the hitch in place. Conical washer teeth side against hitch. Install item 5 over the towhook and through the bracket at the back of the hitch receiver, then loosely install items 6,7 & 8 onto item 5 as shown in Fig. 1.
- Tighten all 7/16"-14 fasteners with torque wrench to 50 Lb.-Ft. (68 N*M) and 3/8"-16 fasteners to 30Lb.-Ft. (41 N*M)**
 **Proper torque is needed to keep the hitch secure to the vehicle when towing.**
- Raise exhaust** - Raise the vehicle exhaust back into position and reinstall all isolators removed in step 1.

Note: check hitch frequently, making sure all fasteners and ball are properly tightened. If hitch is removed, plug all holes in trunk pan or other body panels to prevent entry of water and exhaust fumes. A hitch or ball which has been damaged should be removed and replaced. Observe safety precautions when working beneath a vehicle and wear eye protection. Do not cut access or attachment holes with a torch.

This product complies with safety specifications and requirements for connecting devices and towing systems of the state of New York, V.E.S.C. Regulation V-5 and SAE J684.