



Installation Instructions

PART NUMBERS: 24971, 77971, CQT24971

Applications:

Years	Make	Models
2012-Current*	Toyota	Prius C

Installation Time: 20 min

The time listed above is the average time for professional installers. If you do not feel comfortable performing this installation on your own or are in need of assistance, please contact a professional installer.



Representative Vehicle Photo

Equipment Required:

 Safety Glasses	 Ratchet	 12 mm 13 mm Sockets
 Torque Wrench	 Flat Head Screw Driver	 6" Socket Extension

DO NOT EXCEED LOWER OF TOWING VEHICLE MANUFACTURER'S RATING OR:

Hitch Type	Max Gross Trailer Weight	Max Tongue Weight
Weight Carrying	2000 lb. (908 kg)	200 lb. (90.8kg)
Weight Distributing	N/A	N/A

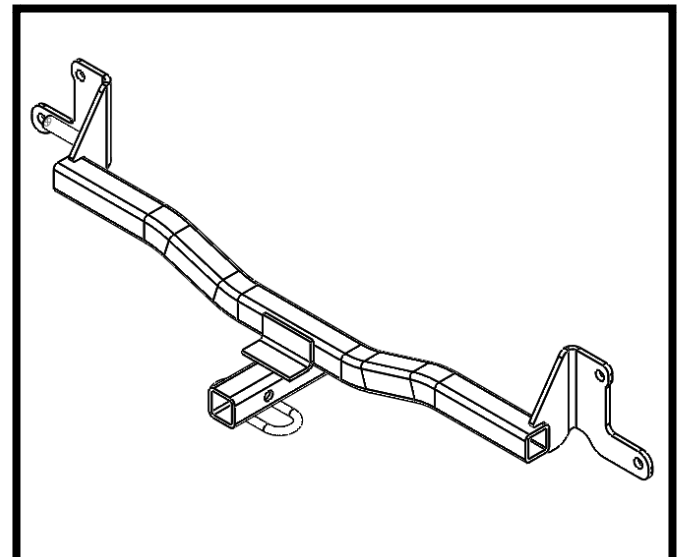

Hitch Illustration





Always wear **SAFETY GLASSES** when installing hitch

Installation Instructions

PART NUMBERS: 24971, 77971, CQT24971

Fastener Kit: 24971F

①	Qty. (4)	Hex Bolt M8x1.25x30mm CL10.9	
②	Qty. (4)	Conical Washer 3/8" Part# 01292006	

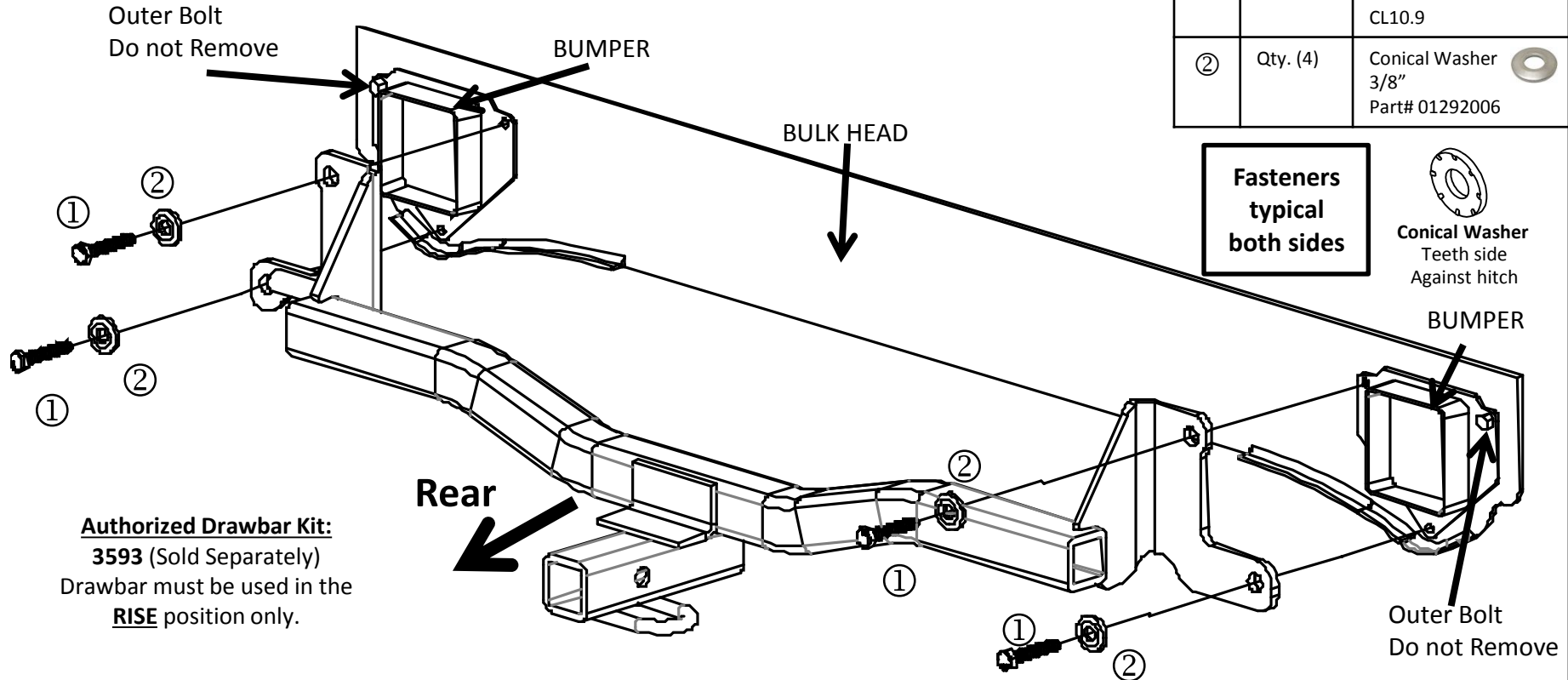

- 1. Remove Appearance Panel** – **Note:** Panels may vary based on vehicle year. Using a flat head screwdriver remove (2) plastic appearance panels from the driver side. (4) push pins per panel (8 push pins total). Then remove the (5) push pins from the center appearance panel. Finally remove the remaining (2) push pins attaching the fascia tabs. **NOTE:** Return the center appearance panel and (5) push pins to the vehicle owner. All other panels and push pins will be reinstalled in step 3.
- 2. Remove Bumper Bolts**– Using a 12mm socket remove the (1) lower bolt and (1) inboard bolt from the bumper (each side) and return (4) bolts to vehicle owner. **NOTE:** Leave the outer bolts attached to the vehicle.
- 3. Hitch installation** – Rotate the passenger side of the hitch over the exhaust and raise into position. Then install items ① and ② each side.
- 4. Torque Fasteners** – Using a 13mm socket Torque all 8mm fasteners to 27 ft-lb (37 N-M)
▲ Proper torque is needed to keep the hitch secure to the vehicle when towing.
- 5. Reinstall Appearance Panels** – Reinstall the (2) driver side appearance panels removed in step one. Then reattach the (2) fascia tabs from step one.

Note: check hitch frequently, making sure all fasteners and ball are properly tightened. If hitch is removed, plug all holes in trunk pan or other body panels to prevent entry of water and exhaust fumes. A hitch or ball which has been damaged should be removed and replaced. Observe safety precautions when working beneath a vehicle and wear eye protection. Do not cut access or attachment holes with a torch. This product complies with safety specifications and requirements for connecting devices and towing systems of the state of New York, V.E.S.C. Regulation V-5 and SAE J684.

1. **Remove Appearance Panel** – **Note:** Panels may vary based on vehicle year. Using a flat head screwdriver remove (2) plastic appearance panels from the driver side. (4) push pins per panel (8 push pins total). Then remove the (5) push pins from the center appearance panel. Finally remove the remaining (2) push pins attaching the fascia tabs. **NOTE:** Return the center appearance panel and 5 push pins to the vehicle owner. All other panels and push pins will be reinstalled in step 6.

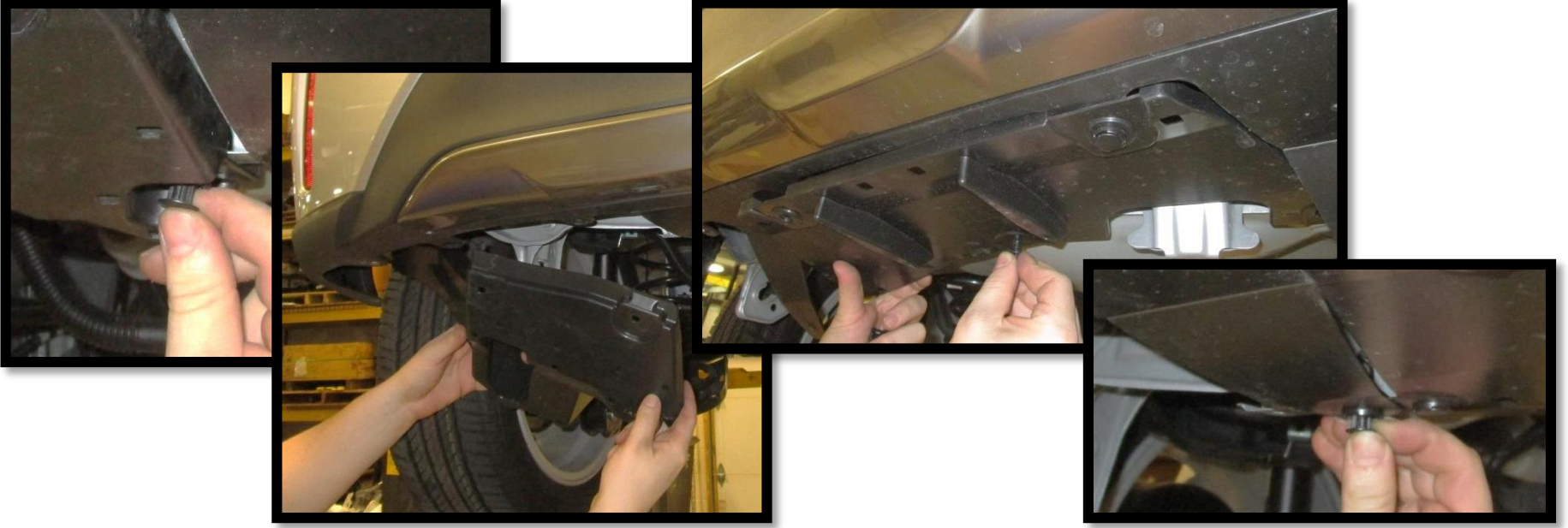

2. **Remove Bumper Bolts**– Using a 12mm socket remove the lower bolt and center bolt from the bumper (each side) and return to vehicle owner. **NOTE:** Leave the outer bolts attached to the vehicle.

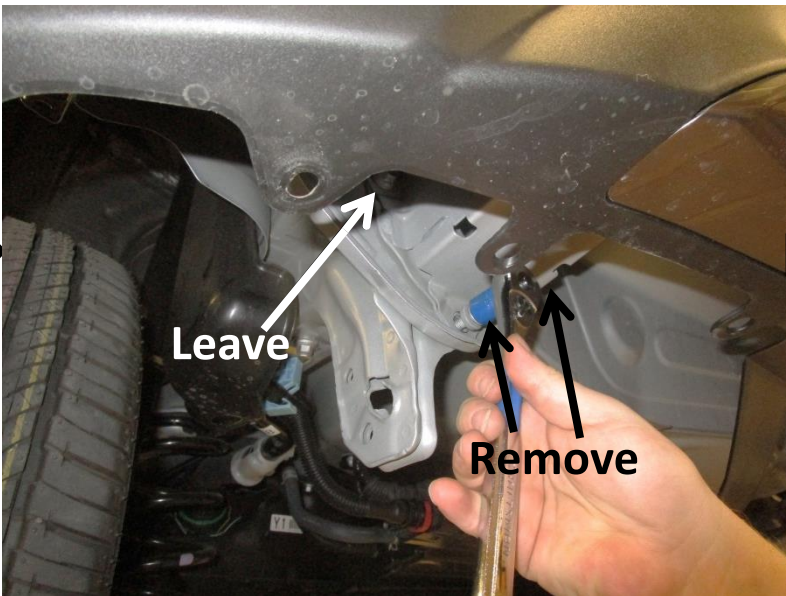

3. **Hitch installation** – Rotate the passenger side of the hitch over the exhaust and raise into position. Then install items ① and ② each side.



4. **Torque Fasteners** – Using a 13mm socket Torque all 8mm fasteners to 27 ft-lb (37 N-M)

 **Proper torque is needed to keep the hitch secure to the vehicle when towing.**



5. **Reinstall Appearance Panels** – Reinstall the (2) driver side appearance panels removed in step one. Then reattach the (2) fascia tabs from step one.



On our website you can discover more about trailer hitches and towing.