



# Installation Instructions

PART NUMBERS: 24963, 77963, CQT24963

## Applications:

Years	Make	Models
2017 -Current*	Hyundai	Ioniq

## Installation Time: 30 min.

The time listed above is the average time for professional installers. If you do not feel comfortable performing this installation on your own or are in need of assistance, please contact a professional installer.



Representative Vehicle Photo

## Equipment Required:

Safety Glasses	Ratchet	10mm 16mm Sockets	Socket Extensions	Torque Wrench	Flat Head Screw Driver	Wire brush
Soapy Water	Exhaust Removal Pliers	Tape Measure	Marker	Utility Knife	Ratchet Strap	OR Bungee Cord

## DO NOT EXCEED LOWER OF TOWING VEHICLE MANUFACTURER'S RATING OR:

Hitch Type	Max Gross Trailer Weight	Max Tongue Weight
Weight Carrying	2000 lb. (908 kg)	200 lb. (90.8 kg)
Weight Distributing	X	X

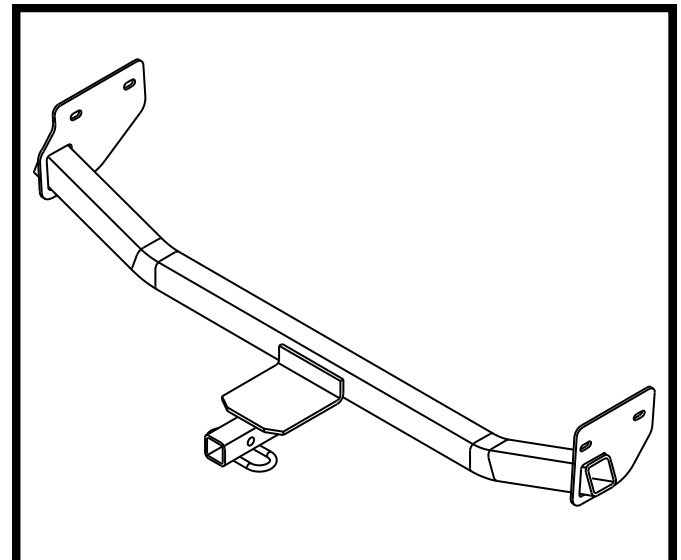

Hitch Illustration

**Always wear SAFETY GLASSES**  
when installing hitch

# Installation Instructions



## PART NUMBERS: 24963, 77963, CQT24963

### Authorized Drawbar Kit:

**3593** (Sold Separately)

Drawbar must be used in the  
**RISE** position only.

Fastener Kit: 24963F

①	Qty. (4)	Bolt M10 X 1.25 X 30 CL10.9	
②	Qty. (4)	Conical Washer 3/8 Part no. 01292006	

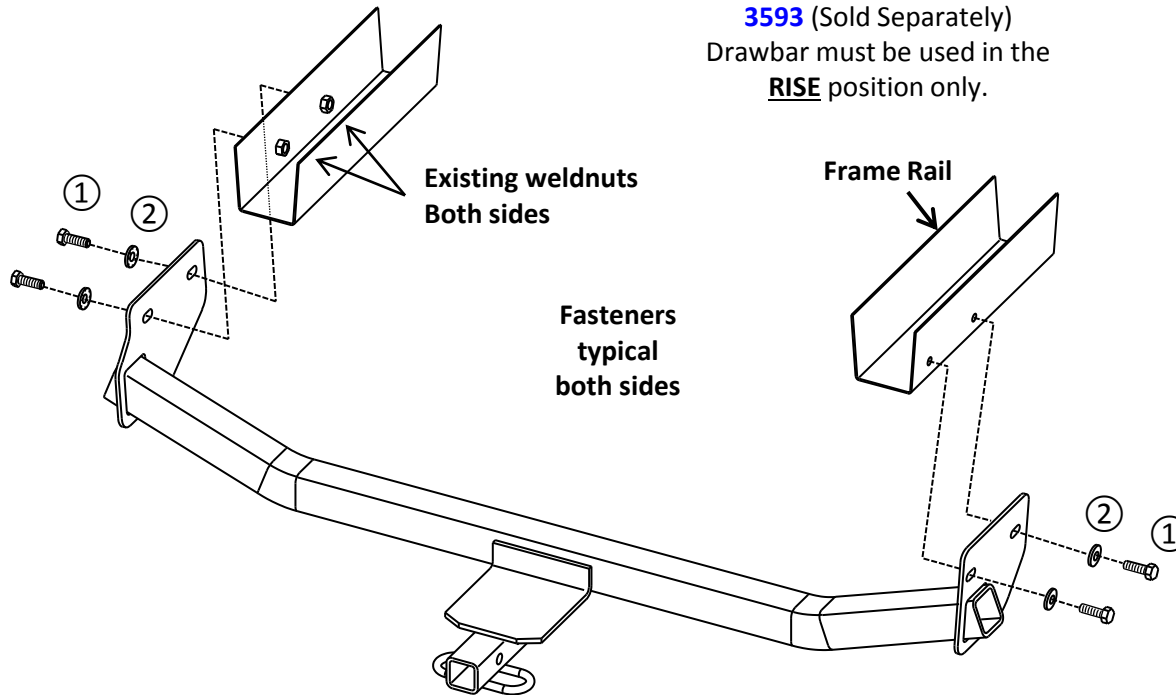

**Figure 1**

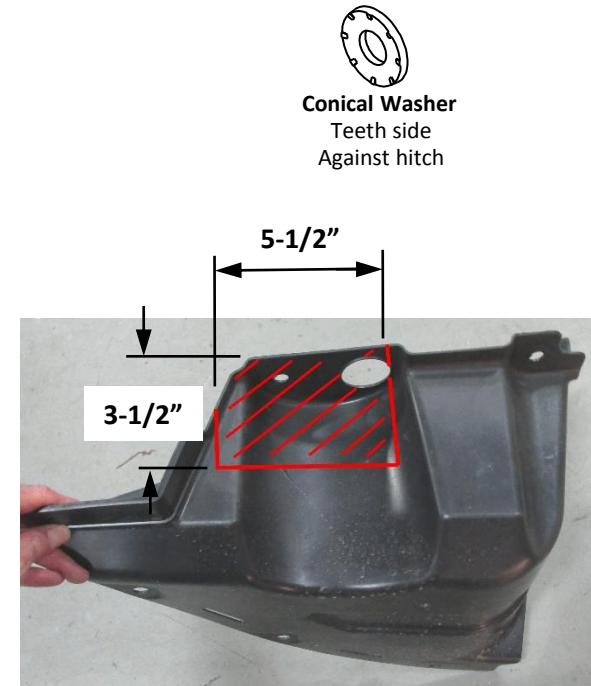
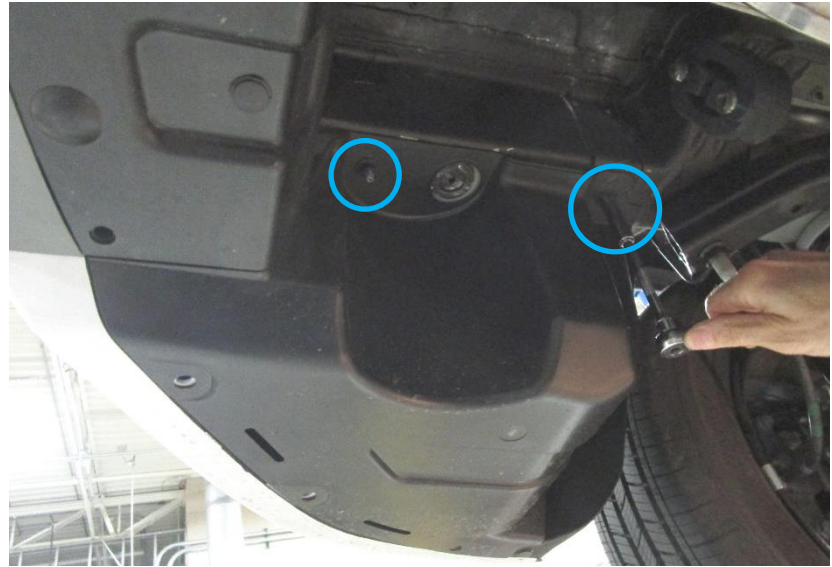

**Figure 2**

- 1. Remove underbody panel** – using a flat head screw driver and a 10mm socket, remove (5) push pin rivets and (2) hex nuts from the driver's side panel. **NOTE:** Two (2) of the rivets connect the driver's side panel to the center panel.
- 2. Lower muffler** – Using an exhaust hanger removal tool, lower muffler by removing (1) rubber hanger on the passenger's side and (1) forward hanger at center of vehicle. A spray a lubricant or soapy water on rubber hangers makes them slide off metal pins more easily. **NOTE: Using a ratchet strap or bungee cord, be sure that exhaust is supported before removing rubber hangers.**
- 3. Install hitch** – Raise hitch into position, raising the passenger's side hitch bracket above the exhaust first, then raise the driver's side into position. Using the supplied hardware, loosely install the M10 bolts and conical toothed washers as shown. **See Figure 1.**  
**NOTE:** It may be necessary to clean debris from existing weldnuts in frame using a wire brush or compressed air.
- 4. Tighten all M10 CL10.9 fasteners with torque wrench to 42 Lb.-Ft. (57 N\*M)**  **Proper torque is needed to keep the hitch secure to the vehicle when towing.**
- 5. Trim underbody panel** – using a tape measure, marker, and utility knife, measure, mark, and trim the driver's side underbody panel. **See Figure 2.**
- 6. Reinstall underbody panel** – reinstall the underbody panel using (5) push pin rivets and (1) hex nut removed in step 1.
- 7. Raise muffler back into position** and reattach all rubber hangers removed in step 2.

Note: check hitch frequently, making sure all fasteners and ball are properly tightened. If hitch is removed, plug all holes in trunk pan or other body panels to prevent entry of water and exhaust fumes. A hitch or ball which has been damaged should be removed and replaced. Observe safety precautions when working beneath a vehicle and wear eye protection. Do not cut access or attachment holes with a torch. This product complies with safety specifications and requirements for connecting devices and towing systems of the state of New York, V.E.S.C. Regulation V-5 and SAE J684.

1. **Remove underbody panel** – using a flat head screw driver and a 10mm socket, remove (5) push pin rivets and (2) hex nuts from the driver's side panel. **NOTE:** Two (2) of the rivets connect the driver's side panel to the center panel.



2. **Lower muffler** – Using an exhaust hanger removal tool, lower muffler by removing (1) rubber hanger on the passenger's side and (1) forward hanger at center of vehicle. A spray a lubricant or soapy water on rubber hangers makes them slide off metal pins more easily. **NOTE: Using a ratchet strap or bungee cord, be sure that exhaust is supported before removing rubber hangers.**

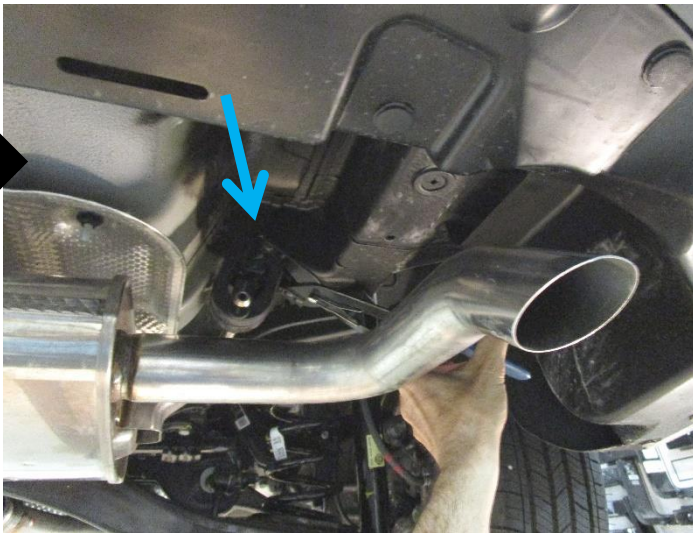



3. **Install hitch** – Raise hitch into position, raising the passenger's side hitch bracket above the exhaust first, then raise the driver's side into position. Using the supplied hardware, loosely install the M10 bolts and conical toothed washers as shown. **See Figure 1.** **NOTE:** It may be necessary to clean debris from existing weldnuts in frame using a wire brush or compressed air.
4. **Tighten all M10 CL10.9 fasteners with torque wrench to 42 Lb.-Ft. (57 N\*M)**  Proper torque is needed to keep the hitch secure to the vehicle when towing.



5. **Trim underbody panel** – using a tape measure, marker, and utility knife, measure, mark, and trim the driver's side underbody panel. **See Figure 2.**

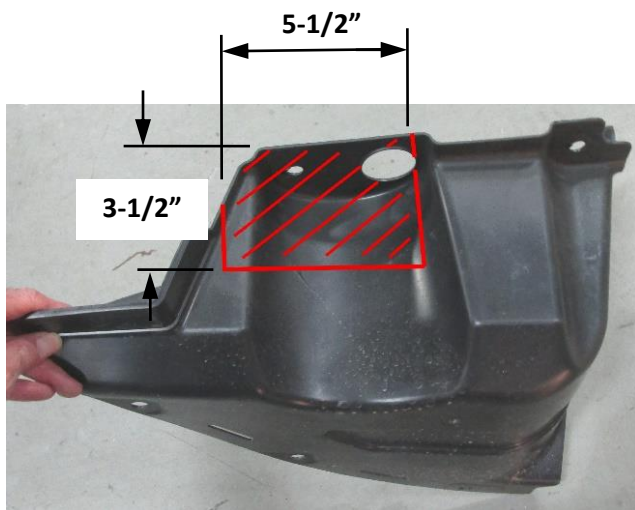

**Figure 2**

6. **Reinstall underbody panel** – reinstall the underbody panel using (5) push pin rivets and (1) hex nut removed in step 1.
7. **Raise muffler back into position** and reattach all rubber hangers removed in step 2.

