

# Installation Instructions

**PART NUMBERS: 24956, 77956, CQT24956**

## Applications:

Years	Make	Models
2017-CURRENT*	CHEVEROLET	BOLT

## Installation Time: 20 min

The time listed above is the average time for professional installers. If you do not feel comfortable performing this installation on your own or are in need of assistance, please contact a professional installer.



**Representative Vehicle Photo**

## Equipment Required:



**DO NOT EXCEED LOWER OF TOWING VEHICLE  
MANUFACTURER'S RATING OR:**

Hitch Type	Max Gross Trailer Weight	Max Tongue Weight
Weight Carrying	2000 lb. (907 kg)	200 lb. (91 kg)
Weight Distributing	N/A	N/A

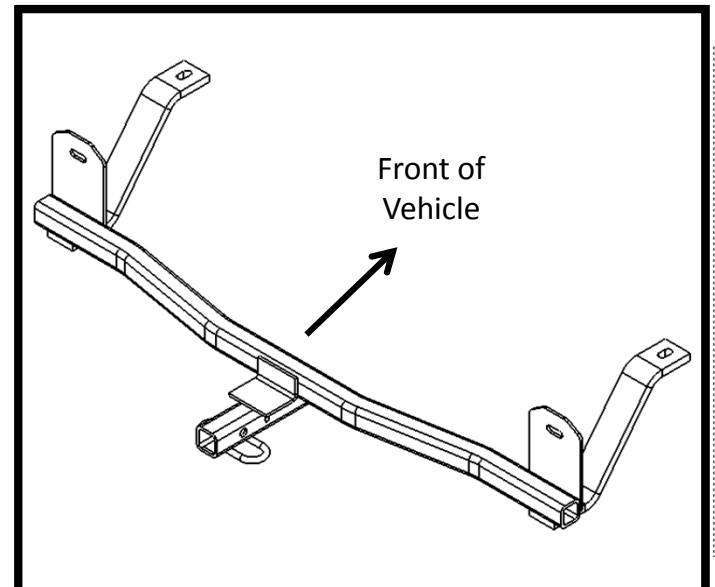





**Hitch Illustration**

**Always wear SAFETY GLASSES when installing hitch**

# Installation Instructions

**PART NUMBERS: 24956, 77956, CQT24956**

**Fastener Kit: 24956F**

①	Qty. (2)	Carriage Bolt 7/16"-14 x 1.75" Gr5	
②	Qty. (2)	Block 1/4" x 7/8" x 3"	
③	Qty. (2)	Nut 7/16"-14 Gr2	
④	Qty. (2)	Conical Tooth Washer 7/16"	
⑤	Qty. (2)	Fish Wire 7/16"	

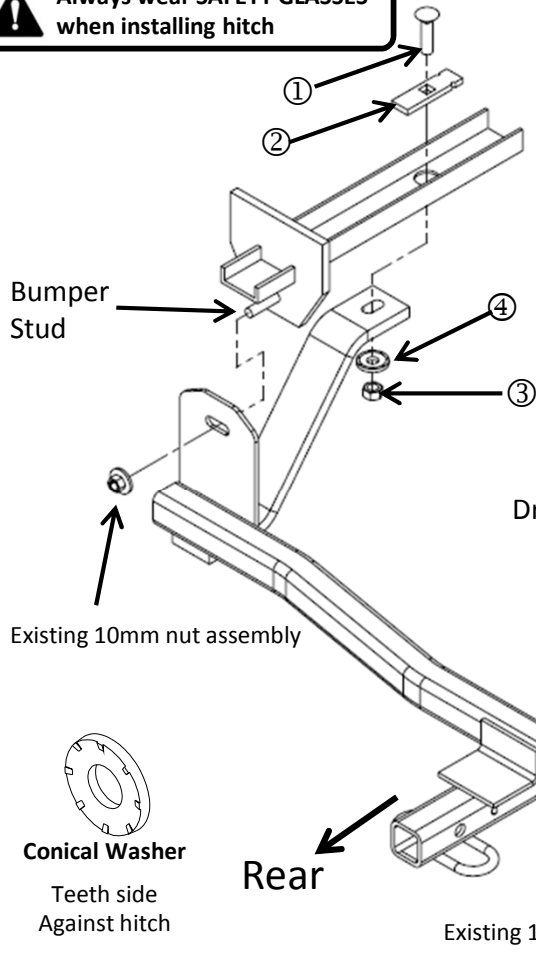
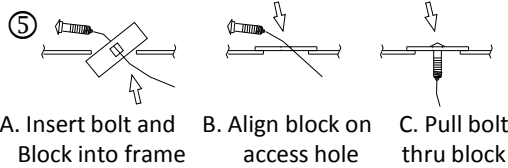

**Authorized Drawbar Kit:  
3593 (Sold Separately)**  
Drawbar must be used in the  
**RISE** position only.

**Figure 1**

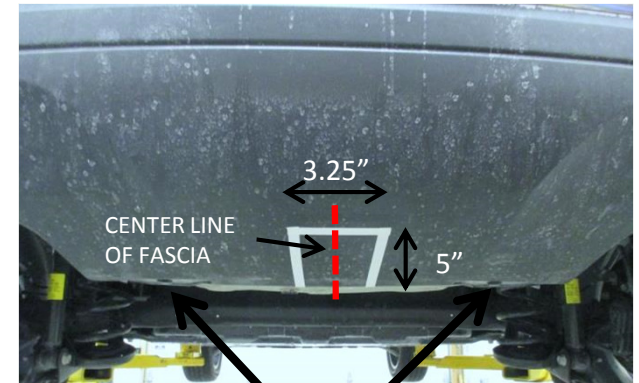
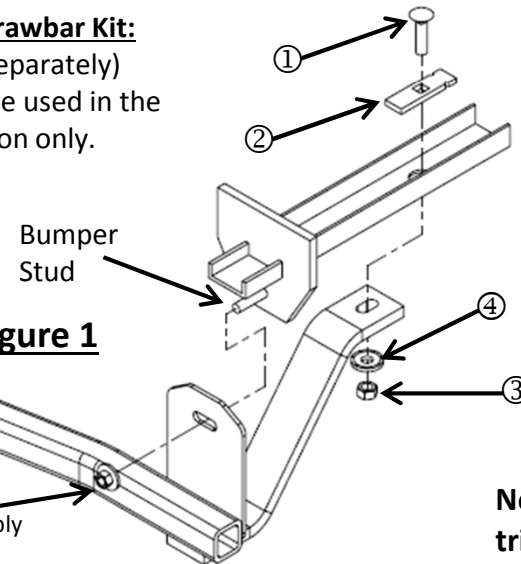

**Figure 2**

**Note: Obtain owners permission before trimming the fascia.**

- 1. Remove Plastic Pins-** Using a flat head screw driver remove the center of the plastic push pin fasteners (2) on the bottom of the fascia. Then remove the remainder of the push pin fastener. See figure 2.
- 2. Remove Hardware-** Using a 15mm socket remove the bottom 10mm nut assembly from the lower bumper stud (1) each side.
- 3. Fish Wire-** Using the reverse fish wire method (step a, b, c pictured above) install items 1 and 2 into the 1 inch hole in the frame (both sides).
- 4. Fascia Trim-** Note: obtain the owners permission before trimming the fascia. In the center (bottom edge) of the fascia measure 3-1/4" wide and 5" tall to trim.
- 5. Install Hitch -** Gently pull on the fascia, raise hitch into position being careful not to push the hardware back into the frame. Reinstall the 10mm nuts removed in step 1. Feed the fish wire through the attachment hole in the hitch then install items 3 and 4.
- 6. Tighten all 7/16-14 GR5 hardware with a torque wrench to 50 Lb.-Ft. (68 n-m) and the 10mm nut assemblies to 38 Lb.-ft. (52 n-m).**  
 Proper torque is needed to keep the hitch secure to the vehicle when towing.
- 7. Reinstall Plastic Pins-** Reinstall the plastic push pin fasteners removed in step 1.

Note: check hitch frequently, making sure all fasteners and ball are properly tightened. If hitch is removed, plug all holes in trunk pan or other body panels to prevent entry of water and exhaust fumes. A hitch or ball which has been damaged should be removed and replaced. Observe safety precautions when working beneath a vehicle and wear eye protection. Do not cut access or attachment holes with a torch.

This product complies with safety specifications and requirements for connecting devices and towing systems of the state of New York, V.E.S.C. Regulation V-5 and SAE J684.

[Learn more about other trailer hitches and towing made by Draw-Tite on our website.](#)