

# INSTALL/REMOVAL INSTRUCTIONS: AIR SUSPENSION CONVERSION KIT

**ATTENTION:** Refer to the appropriate shop manual for your vehicle to obtain specific service procedures for this part. If you do not have a service manual or lack the skill to install this part, it is recommended that you seek the services of a qualified technician. Pay special attention to all cautions and warnings included in the shop manual. Read and follow all instructions carefully.

## **Air Suspension Conversion Kit**

### **General Installation Instructions**

When servicing any vehicle be sure to follow all safety procedures. First, make sure that when lifting the vehicle that you use an appropriate jack with a proper weight rating. Before going underneath any vehicle, make sure that it is properly supported with sturdy jack stands and on level ground so that the vehicle doesn't fall or slide off of the jack and onto you. As with any automotive repair, make sure you have the appropriate tools to do the job so you don't damage any parts on the vehicle. Safety glasses and mechanic's gloves should also be worn for your protection.

Take care not to exceed the Gross Vehicle Weight Rating (GVWR), or the maximum load recommended by the manufacturer. It is important that all the vehicle owner manuals recommendations are followed for your own safety and to prevent damage to the vehicle.

Once you are ready to disable the ride light, you will need to disconnect the negative battery cable (-) to prevent electrical shock/malfunction.

#### **Disclaimer:**

Even though every attempt is made to ensure this information is complete and accurate, it is impossible to account for all possible circumstances or situations. Please consult with a qualified auto technician before attempting to perform any work you are not qualified to do. Automobiles can be hazardous to work on; be sure to take all necessary safety precautions. Failure to do so may result in property damage or personal injury. Certain motor vehicle standards and performance requirements may apply to your motor vehicle (such as Federal Motor Vehicle Safety Standards by the National Highway Traffic Safety Administration). Be sure that your work is performed in accordance with such standards and that you do not disable any motor vehicle safety feature.

**ATTENTION:** Refer to the appropriate shop manual for your vehicle to obtain specific service procedures for this part. If you do not have a service manual or lack the skill to install this part, it is recommended that you seek the services of a qualified technician. Pay special attention to all cautions and warnings included in the shop manual. Read and follow all instructions carefully.

## Front Kit

Read instructions before attempting installation. If there are any installation problems or questions call our Technical Support Line.

### Front Removal and Installation Instructions

Read the instructions sheet and any instructions printed on the parts package carefully prior to removing the strut from the vehicle.

- Do not grip polished rod with any tool. Nicks or scratches will cause decreased service life.
- Part number on the unit may differ from part number on the vehicle.
- If you have any questions during installation you can call for Tech Assistance.



If this unit is gas pressurized, do not heat or open. Always wear safety glasses for eye protection. Use safety stands whenever a procedure requires you to under the vehicle.

### Strut Assembly Replacement

1. Raise and support the vehicle and remove the front wheel and tire assembly.

Fig. 1

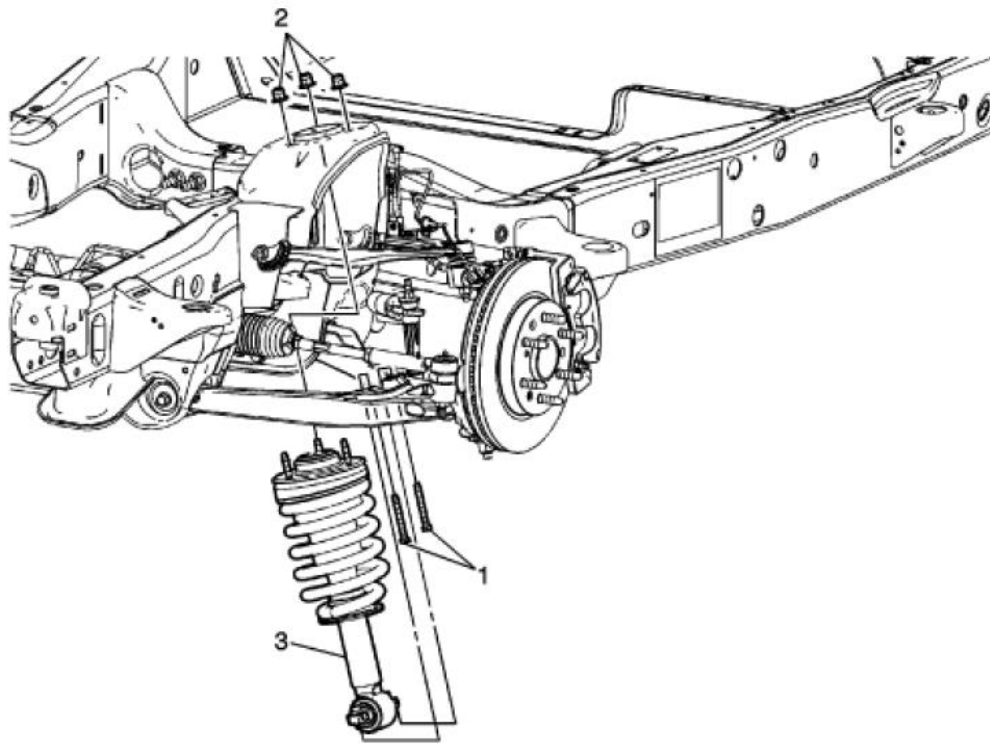

Disclaimer:

Even though every attempt is made to ensure this information is complete and accurate, it is impossible to account for all possible circumstances or situations. Please consult with a qualified auto technician before attempting to perform any work you are not qualified to do. Automobiles can be hazardous to work on; be sure to take all necessary safety precautions. Failure to do so may result in property damage or personal injury. Certain motor vehicle standards and performance requirements may apply to your motor vehicle (such as Federal Motor Vehicle Safety Standards by the National Highway Traffic Safety Administration). Be sure that your work is performed in accordance with such standards and that you do not disable any motor vehicle safety feature.

**ATTENTION:** Refer to the appropriate shop manual for your vehicle to obtain specific service procedures for this part. If you do not have a service manual or lack the skill to install this part, it is recommended that you seek the services of a qualified technician. Pay special attention to all cautions and warnings included in the shop manual. Read and follow all instructions carefully.

2. **Disconnect the outer tie rod from the steering knuckle. It may be necessary to use a special puller to separate the tie rod end from the steering knuckle.**

**Only loosen the inner tie rod nut, marked as 2 in the figure below, Do Not Remove It**

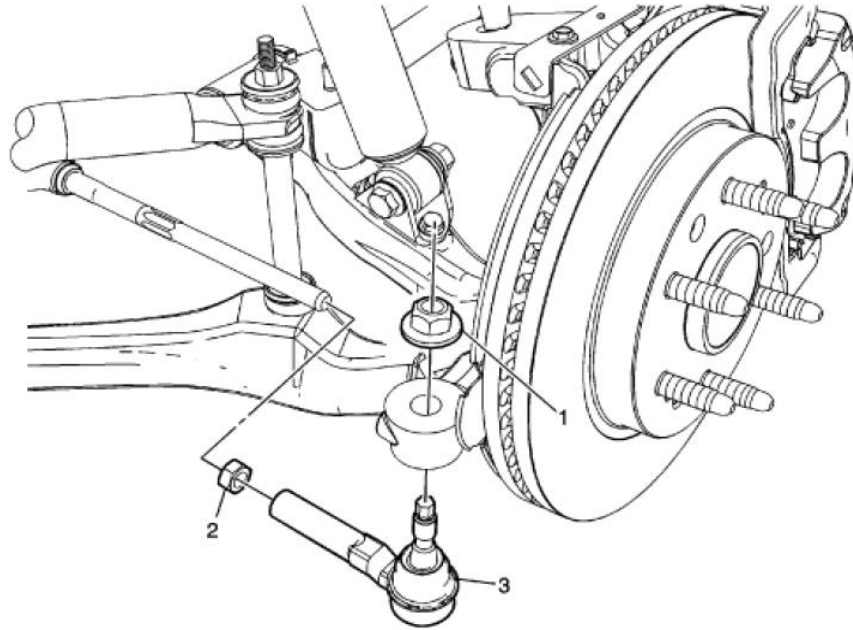

3. **Support the lower control arm. (Fig. 2)**  
**Disconnect the electronic suspension electrical connector (Fig. 3)**  
**Now you can remove the two lower strut retaining bolts, marked as 1 in illustration Fig. 1**  
**Note: Do not use air tools for this process**  
**(Torque Spec 37ft.lbs for these two bolts)**

Fig. 2

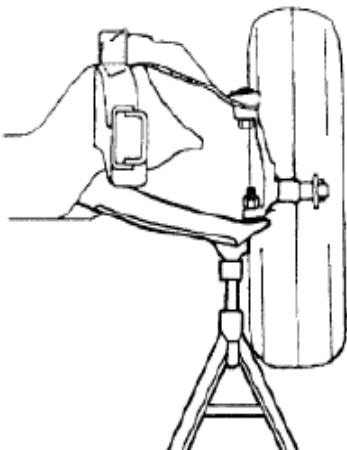
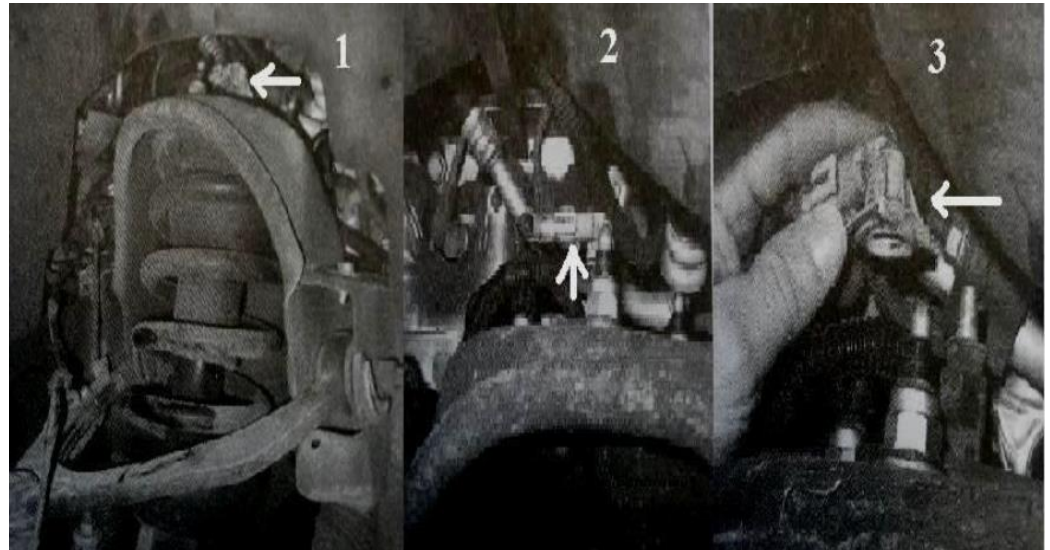

Fig. 3



Disclaimer:

Even though every attempt is made to ensure this information is complete and accurate, it is impossible to account for all possible circumstances or situations. Please consult with a qualified auto technician before attempting to perform any work you are not qualified to do. Automobiles can be hazardous to work on; be sure to take all necessary safety precautions. Failure to do so may result in property damage or personal injury. Certain motor vehicle standards and performance requirements may apply to your motor vehicle (such as Federal Motor Vehicle Safety Standards by the National Highway Traffic Safety Administration). Be sure that your work is performed in accordance with such standards and that you do not disable any motor vehicle safety feature.

**ATTENTION:** Refer to the appropriate shop manual for your vehicle to obtain specific service procedures for this part. If you do not have a service manual or lack the skill to install this part, it is recommended that you seek the services of a qualified technician. Pay special attention to all cautions and warnings included in the shop manual. Read and follow all instructions carefully.

4. Next remove the three strut mounting nuts on the top, marked as 2 in Fig.1 on the previous page. (Torque spec. 37ft. lbs for these three nuts)
5. Now you should be able to simply lower the strut assembly (marked as 3 in Fig. 1 on the previous page) out of the vehicle.
6. Installation of the new assembly will be the reverse order of the previous five steps

### Air Suspension Light Disarm Instructions

1. Check codes using appropriate scan tool and record.
2. Clear codes.
3. Crimp electronic units that came with the kit to the wire that was unplugged from the factory struts and shocks. Note: You will have to cut the factory plug off the wire and strip to crimp electronic unit. One lead per wire.
4. After installation, the air compressor pump must be disabled. To do this, remove the inner fender well liner on the driver side rear wheel well to gain access to the compressor electrical connector and unplug it. Refer to illustration below. Connector is labeled as #2

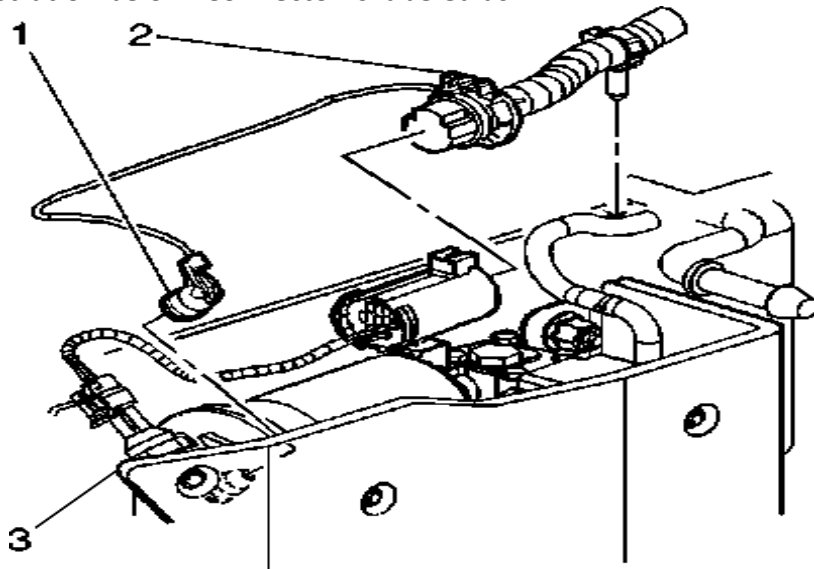

5. Reinstall fender liner shield.
6. The dedicated fuse for the compressor pump can be removed instead of unplugging the compressor. Refer to owner's manual for fuse location.
7. It may be necessary to reset the vehicles' ECU, after the installation process, using a scan tool.

It is recommended that the alignment be reset after installation

Dorman provides the best in performance suspension parts equipment.