

INSTALL/REMOVAL INSTRUCTIONS: AIR SUSPENSION CONVERSION KIT

ATTENTION: Refer to the appropriate shop manual for your vehicle to obtain specific service procedures for this part. If you do not have a service manual or lack the skill to install this part, it is recommended that you seek the services of a qualified technician. Pay special attention to all cautions and warnings included in the shop manual. Read and follow all instructions carefully.

Air Suspension Conversion Kit

General Installation Instructions

When servicing any vehicle be sure to follow all safety procedures. First, make sure that when lifting the vehicle that you use an appropriate jack with a proper weight rating. Before going underneath any vehicle, make sure that it is properly supported with sturdy jack stands and on level ground so that the vehicle doesn't fall or slide off of the jack and onto you. As with any automotive repair, make sure you have the appropriate tools to do the job so you don't damage any parts on the vehicle. Safety glasses and mechanic's gloves should also be worn for your protection.

Take care not to exceed the Gross Vehicle Weight Rating (GVWR), or the maximum load recommended by the manufacturer. It is important that all the vehicle owner manuals recommendations are followed for your own safety and to prevent damage to the vehicle.

Once you are ready to disable the ride light, you will need to disconnect the negative battery cable (-) to prevent electrical shock/malfunction.

Disclaimer:

Even though every attempt is made to ensure this information is complete and accurate, it is impossible to account for all possible circumstances or situations. Please consult with a qualified auto technician before attempting to perform any work you are not qualified to do. Automobiles can be hazardous to work on; be sure to take all necessary safety precautions. Failure to do so may result in property damage or personal injury. Certain motor vehicle standards and performance requirements may apply to your motor vehicle (such as Federal Motor Vehicle Safety Standards by the National Highway Traffic Safety Administration). Be sure that your work is performed in accordance with such standards and that you do not disable any motor vehicle safety feature.

ATTENTION: Refer to the appropriate shop manual for your vehicle to obtain specific service procedures for this part. If you do not have a service manual or lack the skill to install this part, it is recommended that you seek the services of a qualified technician. Pay special attention to all cautions and warnings included in the shop manual. Read and follow all instructions carefully.

Installation Guide

Ford Windstar

1995 - 2003

Parts included in this kit

- (2) #12 Coil Springs



Tools needed for installation

- Metric socket set
- Floor jack
- Jack stands
- Metric wrenches
- Screwdrivers (Phillips and flat head)
- Wire cutter/stripper/crimping tool
- Level work surface
- Spring compressor (if applicable)
- Allen wrenches

Disclaimer:

Even though every attempt is made to ensure this information is complete and accurate, it is impossible to account for all possible circumstances or situations. Please consult with a qualified auto technician before attempting to perform any work you are not qualified to do. Automobiles can be hazardous to work on; be sure to take all necessary safety precautions. Failure to do so may result in property damage or personal injury. Certain motor vehicle standards and performance requirements may apply to your motor vehicle (such as Federal Motor Vehicle Safety Standards by the National Highway Traffic Safety Administration). Be sure that your work is performed in accordance with such standards and that you do not disable any motor vehicle safety feature.

ATTENTION: Refer to the appropriate shop manual for your vehicle to obtain specific service procedures for this part. If you do not have a service manual or lack the skill to install this part, it is recommended that you seek the services of a qualified technician. Pay special attention to all cautions and warnings included in the shop manual. Read and follow all instructions carefully.

Ford Windstar 1995 - 2003 Rear Kit Installation Instructions

Note: If you've purchased a 4-wheel kit, install both kits before disarming the ride light.

Rear Removal & Installation Instructions

Read instructions carefully before attempting installation. If you have problems during the installation, call our Technical Support Line.

1. Raise and support the vehicle, then remove the wheels and tires.
2. Remove spindle & brake backing plate assemblies. Supporting off to the side, disconnecting emergency brake cables, anti-lock sensor wiring & connectors & brake cables, anti-lock sensor wiring & connectors & brake fluid lines as necessary.
3. Disconnect track arm at attachment to rear axle.
4. Support rear axle at both sides, then remove both Air Springs.
5. Remove rear axle trailing arm to frame attaching bolts, then lower axle from vehicle.
6. Reverse procedure to install coil springs. (See Figure 1)

Fig. 1

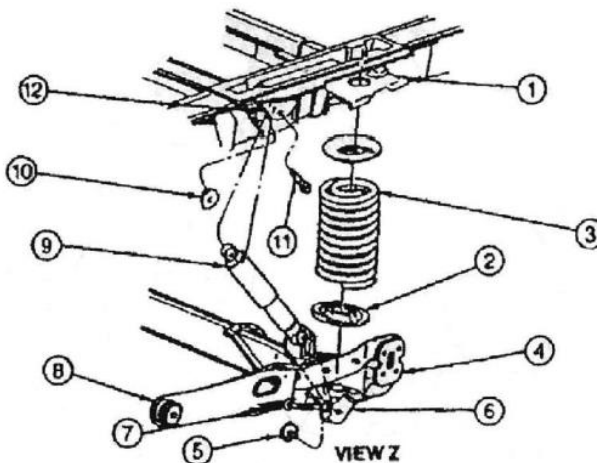

Item	Description
1	Upper Spring Seat (Part of Unibody)
2	Rear Spring Insulator
3	Rear Spring
4	Rear Axle Assembly
5	Nut
6	Lower Shock Mounting Bracket (Part of 4B435)

Item	Description
7	Bolt
8	Trailing Arm (Part of 4B435)
9	Shock Absorber
10	Nut
11	Bolt
12	Upper Shock Absorber Mounting Bracket (Part of Unibody)

Note: The rear springs may settle some during the first couple of weeks of use. It may be necessary to adjust the front height sensors to match the level of the new rear springs. The rear springs can sit a little low if the rear shocks are bad. Test the rear shocks by pushing down on the rear of the car. If the rear bounces, then replace the shocks as well.

Dorman provides the best in performance suspension parts equipment.