



TOMORROW'S TECHNOLOGY

TOMORROW'S TECHNOLOGY · TODAY'S CONTROL ARM SOLUTIONS

Dorman's exclusive T2 line of Control Arms utilize advanced polymer bearings and highly polished ball studs, completely eliminating the need for regular greasing.

MAINTENANCE FREE SEALED DESIGN

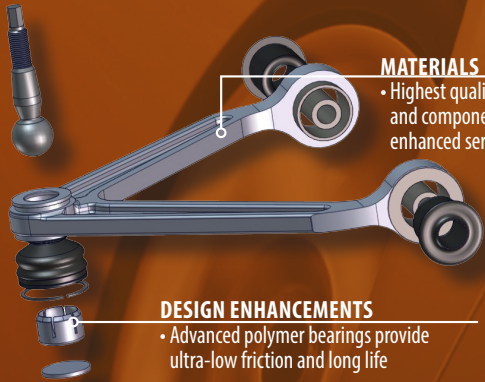

MATERIALS

- Highest quality materials and components utilized for enhanced service life

DESIGN ENHANCEMENTS

- Advanced polymer bearings provide ultra-low friction and long life
- Metal-on-metal designs solve a problem that no longer exists. The weak plastic bearings used decades ago have been replaced by today's superior plastic polymers.



Graded hardware provides simple installation and reliable connection



Polychloroprene Boot with Integrated Ring results in a weather-tight seal, while resisting dry rot and abrasions



Polished and hardened Ball Stud provides strength and rigidity with a smoother rotation that yields increased service life



Medium Carbon Steel Housing is precisely machined for secure fit and coated for added corrosion resistance



Dorman engineered Polymer Bearing provides smooth movement with a high tolerance of temperature extremes; without requiring regular maintenance



Weather-tight Sealing Coin prevents moisture and debris from contaminating housing

QUALITY & INNOVATION

We know Techs demand quality products.

From ball studs to hardware, Dorman designs and quality tests each individual component of our Control Arms to deliver exceptional performance, maintenance free technology and trouble free installation.

Our comprehensive coverage, enhanced with maintenance-free T2 technology, provides Technicians with a complete Control Arm solution.



INDUSTRY LEADING COVERAGE

Over 1.3 Billion Repair Opportunities

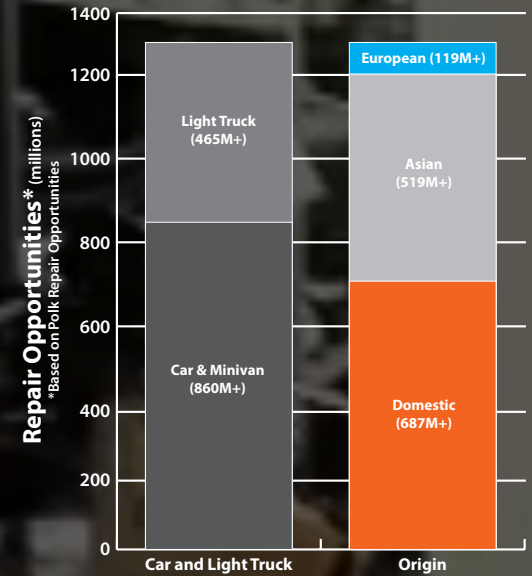

COVERAGE

We know Techs must be able to service every vehicle that enters their shop.

With over 2,500 Control Arms currently available, Dorman offers market leading coverage. Our growing offering provides comprehensive coverage for over 1.3 billion repair opportunities on the road today.

Dorman's Chassis-focused product team focuses on vehicle population data and prioritizes development based on OE failure trends, ensuring Aftermarket availability for today's most relevant and in-demand Control Arms.



TOMORROW'S TECHNOLOGY

TOMORROW'S TECHNOLOGY · TODAY'S CONTROL ARM SOLUTIONS

COMPETITIVE CLAIM

FACT

Greaseable ball joints increase service life

- Greaseable ball joints must be lubricated, or they will deteriorate quickly
- Requires technician to know (or notice) that maintenance is required
- Not compatible with modern vehicles' longer service intervals

Plastic bearings do not provide continuous lubrication

Self lubrication provides a constant low friction coefficient, resulting in smoother operation

Heat over 140°F will soften the bearing

Dorman's polymer blend is engineered to withstand temperatures up to 200°F, well above even the most extreme operating conditions

Larger castings reduce twisting and breaking

Oversize castings add minimal structural strength, and are primarily used to accommodate standardized ball studs. Dorman always matches OEM ball stud size; never relying on standardized ball stud designs.

Aluminum control arms are less durable

Aluminum control arms have proven to be durable, while reducing weight and resisting corrosion. This durability has led the OEMs to increasingly use aluminum designs in today's newest vehicles.

Grease relief valve prevents contamination

A "valve" is a flap that is susceptible to external pressure, eventually allowing contaminants to enter ball stud housing.

WHAT MAKES DORMAN DIFFERENT

Dorman replaces old style bearings with updated polymers – delivering the benefits of today's technology across a broad range of early to late model applications.

Dorman's maintenance-free Ball Joints utilize the latest self-lubricating metal-on-plastic designs with added features such as premium boot seals and highly polished ball studs to provide the durability needed for long service life.

