

DirtBound OFFROAD

DIY Mojave Rear



The Mojave Rear DIY bumper kit is designed to be built with basic welding and metalworking skills and should take approximately 4-8 hours to complete.

You will need the following tools

- | | |
|---|--|
| <ul style="list-style-type: none">• Welder & Safety Gear• Angle Grinder & Sanding Disks• Angle Finder• Rubber Mallet• Two Crescent Wrenches• Minimum of two welding Clamps | <ul style="list-style-type: none">• Heavy Workbench• 15mm, 19mm, Wrench & Socket Wrench• Allen Head Socket |
|---|--|

DirtBound Inc. is not responsible for incorrect assembly, we recommend only experienced welders assemble our DIY bumper kits.
Always tack the assembly and test fit on the vehicle before fully welding.

You purchase DirtBound Inc. products at your own risk. In no event, shall DirtBound Inc.'s liability ever exceed the purchase price of any part sold. DirtBound Inc. shall not be liable for any indirect, special, incidental or consequential damages, nor for inconvenience or loss of use, including the cost of a rental car, storage charges, towing charges, telephone calls, legal fees and costs, labor costs and any additional parts required to remove and replace the defective or worn-out part.

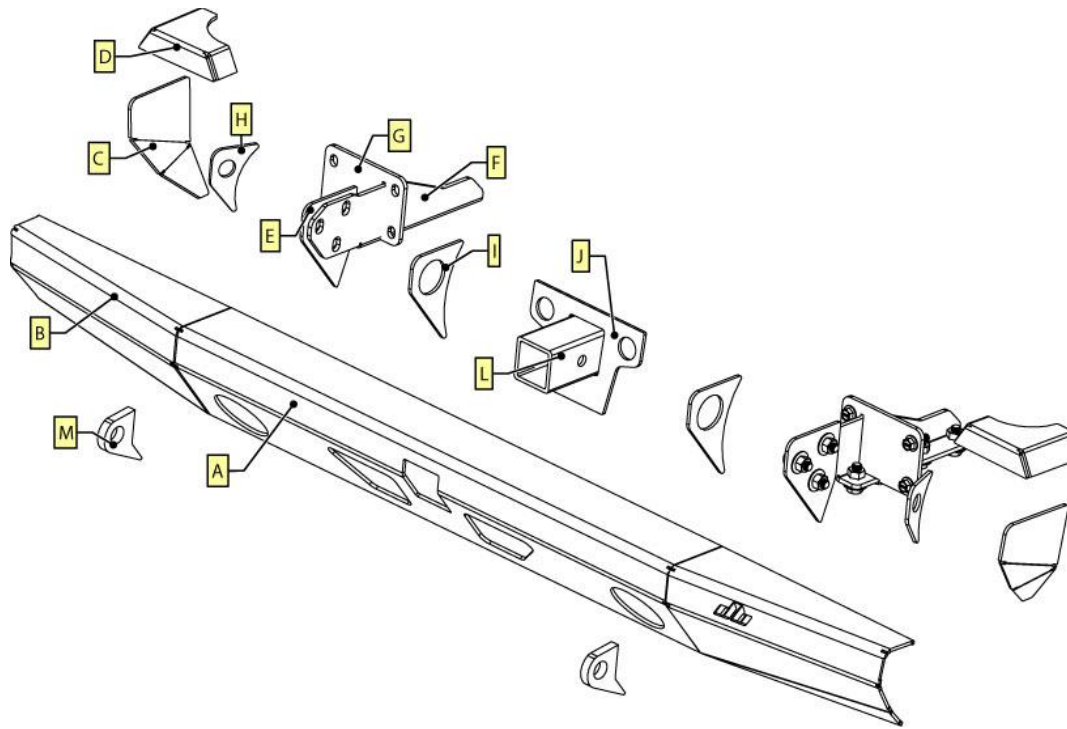

Parts List

- A. 1 x Center
- B. 2 x Side Panels
- C. 2 x End Cap

- D. 2 x Tail Light Cap
- E. 2 x Bumper Bracket
- F. 2 x Uni-Body Bracket
- G. 2 x Uni-Body Bkt Flange
- H. 2 x SM Gusset
- I. 2 x LG Gusset
- J. 1 x Receiver Support
- K. 1 x Receiver Tube
- L. 2 x D Ring Tabs
- M. 1 x Hardware Kit

Bend Angles

The parts are slotted at the bend lines, to bend simply clamp the part to the work bench and use one or two crescent wrenches to bend the part to the desired angle.

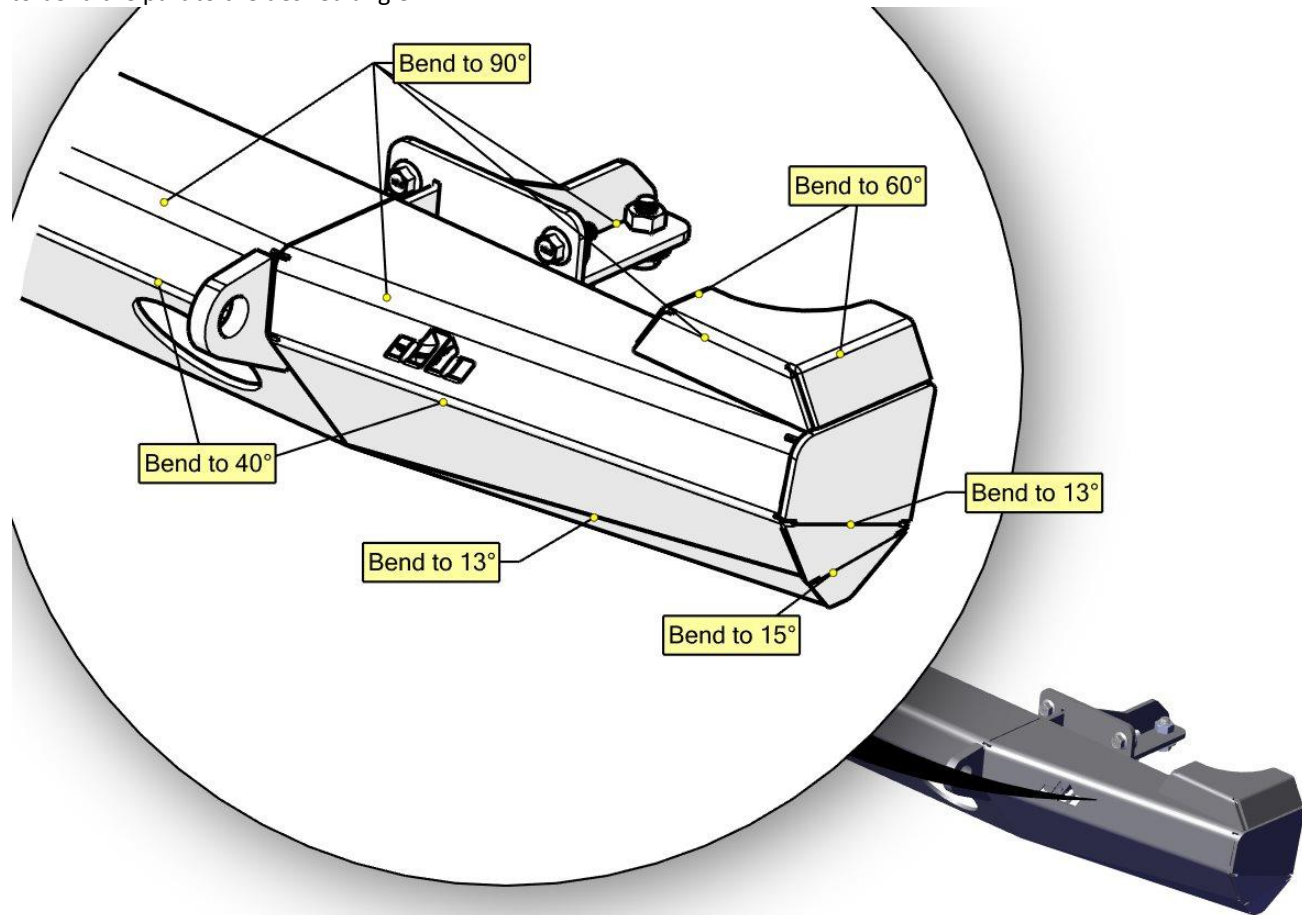

Uni-Body Bracket

Weld the Uni-Body Bracket and Bracket Flange as shown in the diagram by lining the flange up to the tab on the Uni-Body Bracket. The 8 included uncoated weld nuts are to be welded to the bracket, all new hardware is provided except the 8 factory bumper bolts that will be re-used.

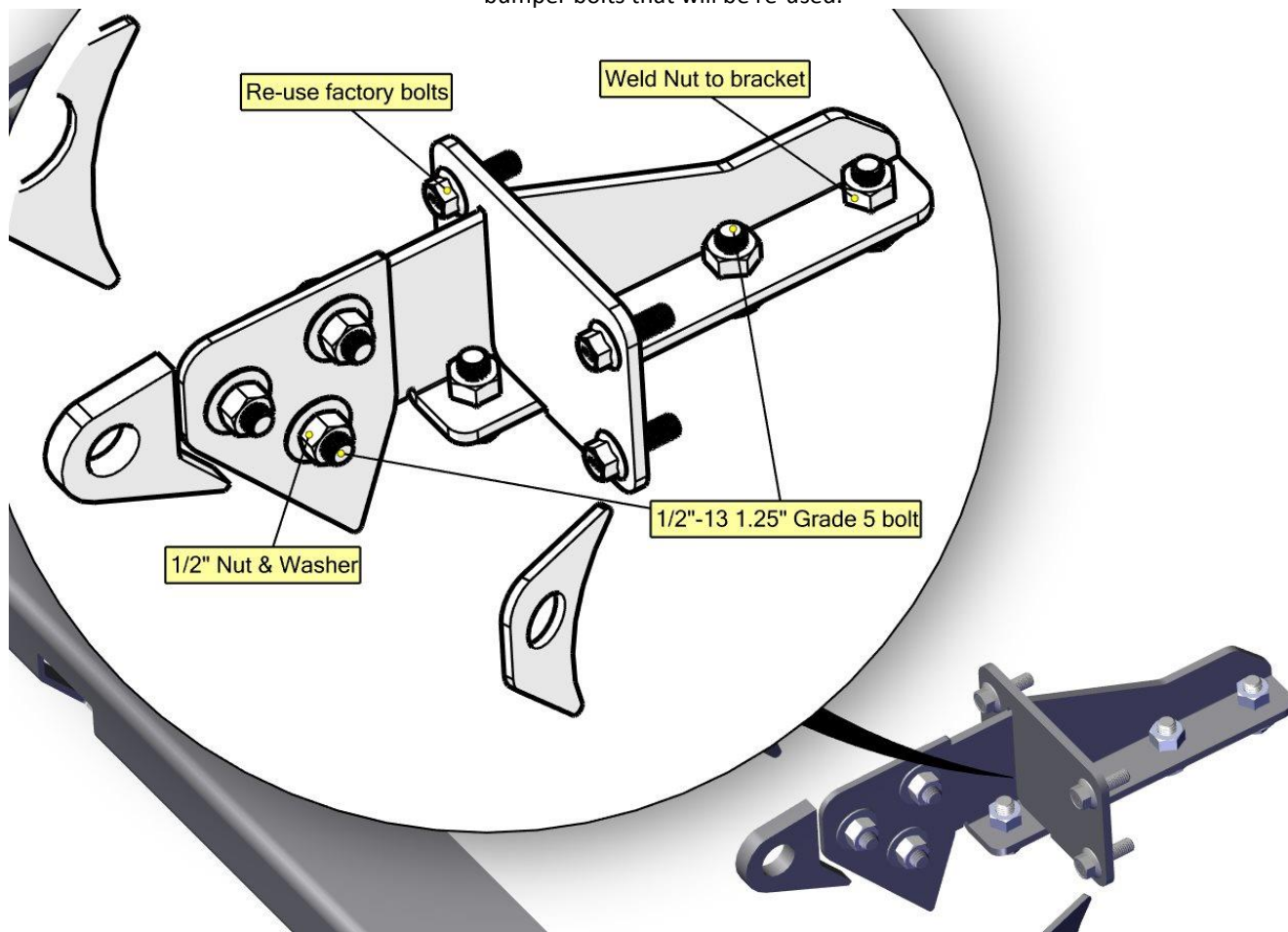

Brackets and Gussets

After bending the parts to the correct angle, we recommend tacking the outer shell (Center & Side Panels) together and then tack the Gussets and Brackets to the outer shell.

The bumper brackets (three slotted holes) are to be welded at 34.5" Inside Dimension, as always tack and test fit before fully welding.

The gussets are then spaced evenly with the large gussets installed between the receiver and bumper bracket, and the small gusset on the side panel between the bracket and end cap.

To weld the hitch in we space it 1/2" from the face of the bumper, making sure to orient the pin hole side to side and then slide the receiver support plate over the tube and tack all in place.

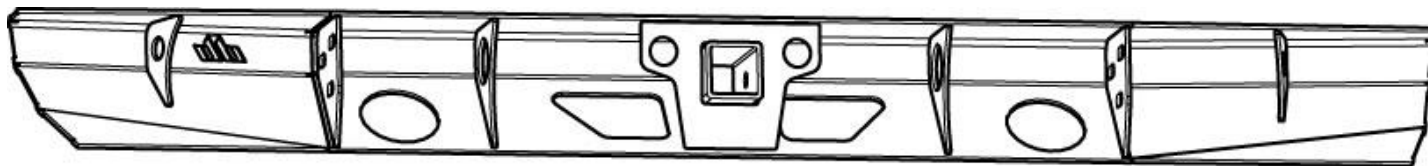

End Cap & Tail Light Caps

Now tack the end caps to the end of the bumper, the top of the bumper should be flush with the top of the end cap. Then tack the tail light cap on top with the outside edge flush with the end cap while making sure the inside edge is flush with the back of the bumper.

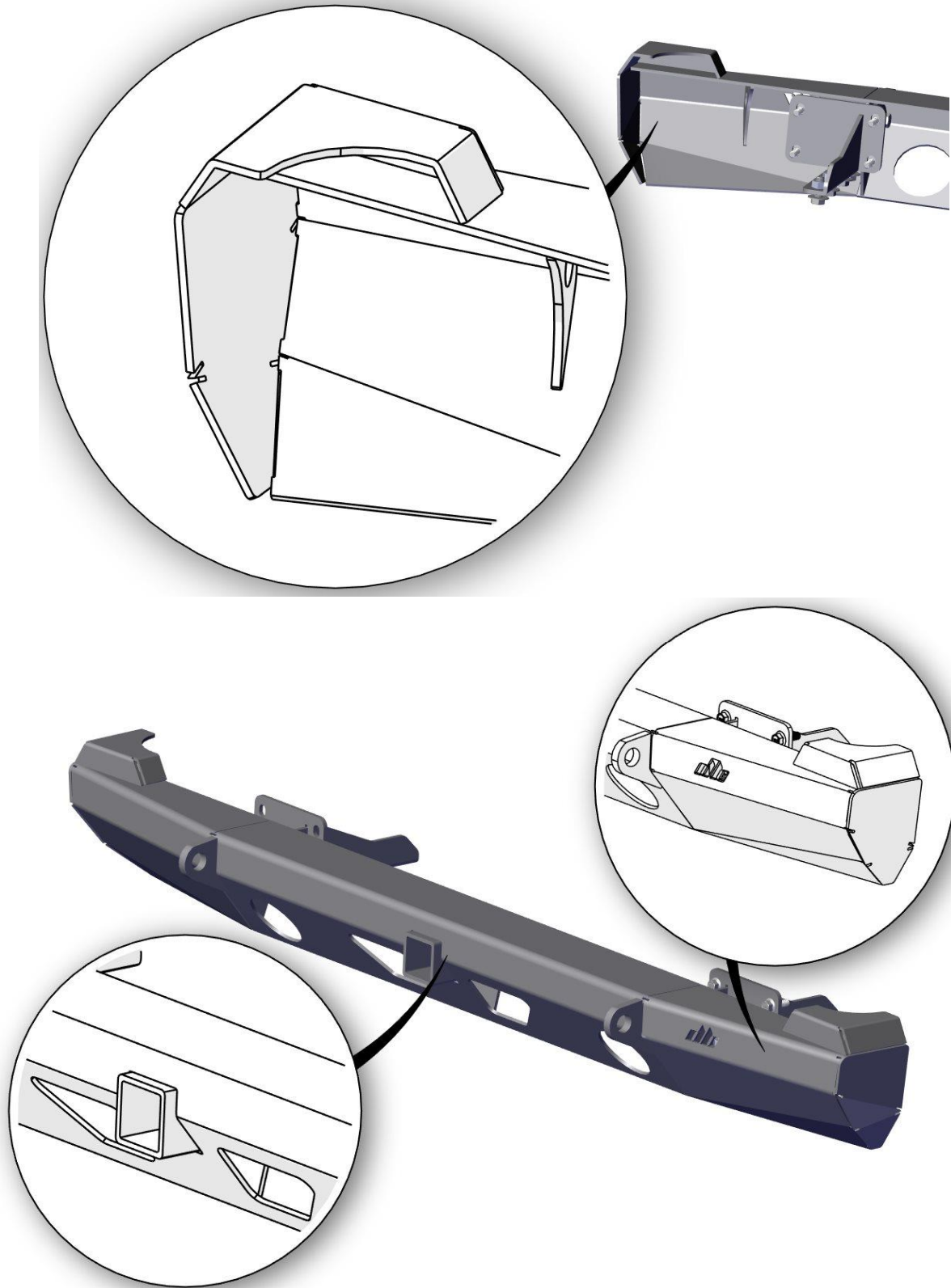

D Ring Tabs

Position the D Ring Tabs with the bumper skin seam, this is the strongest place of the bumper as it provides a straight pull to the uni-body. Make sure to clean the area and set the welder to the proper settings for welding ½" steel.

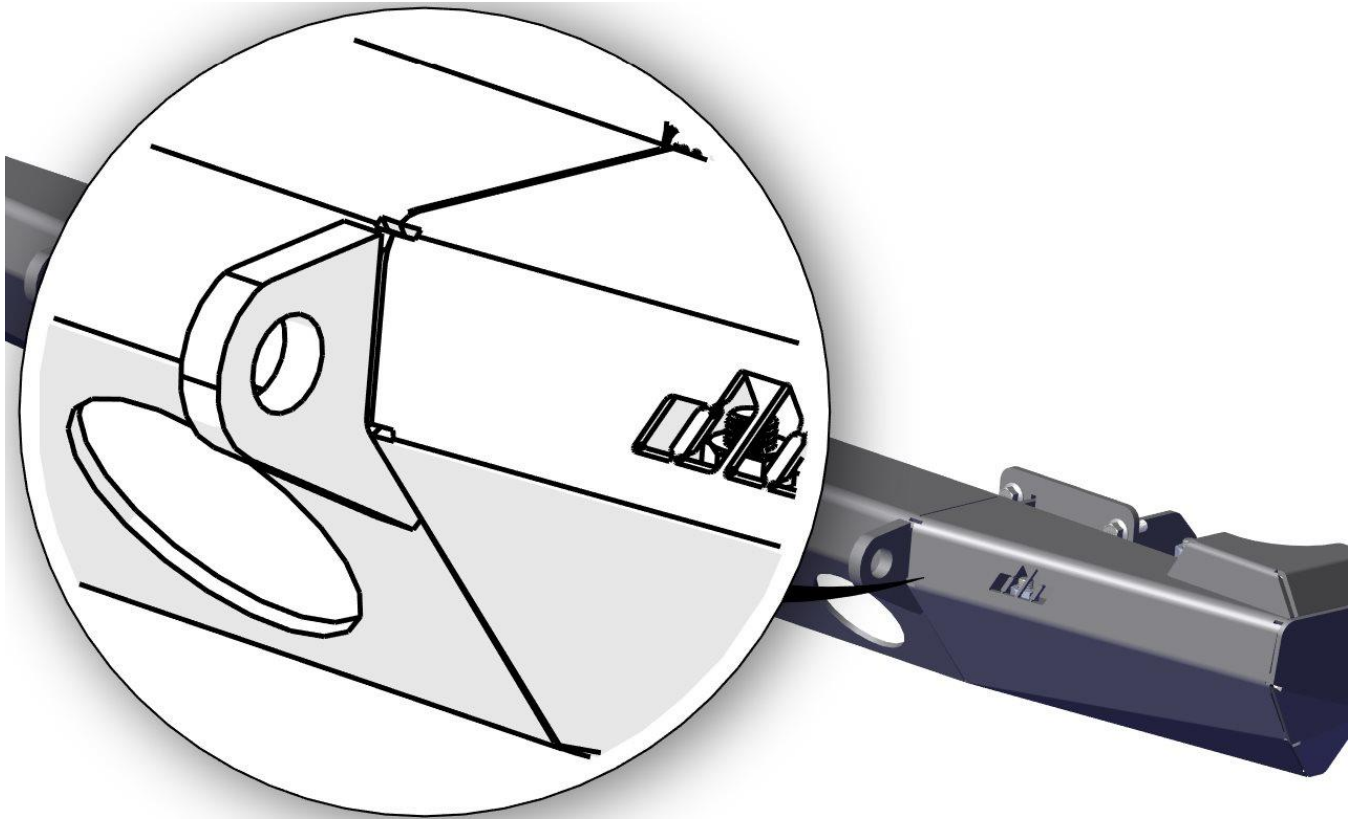

Finish weld and Sand

After test fitting the bumper on the Jeep, fully weld all the seams and sand smooth for a clean finished look. Install the bumper by first mounting the uni-body brackets into the jeep and only finger tighten the bolts, slide the bumper over the brackets and install the 3 bolts per side. With a helper align the bumper to the body and then tighten the hardware.

